



CINTERION  
WIRELESS MODULES

# TC35i TC35i Terminal

Version: 03.01  
DocId: TC35i\_ATC\_V03.01n



AT Command Set

Document Name: **TC35i AT Command Set**

Version: **03.01**

Date: **August 4, 2008**

DocId: **TC35i\_ATC\_V03.01n**

Status **Confidential / Released**

**GENERAL NOTE**

THE USE OF THE PRODUCT INCLUDING THE SOFTWARE AND DOCUMENTATION (THE "PRODUCT") IS SUBJECT TO THE RELEASE NOTE PROVIDED TOGETHER WITH PRODUCT. IN ANY EVENT THE PROVISIONS OF THE RELEASE NOTE SHALL PREVAIL. THIS DOCUMENT CONTAINS INFORMATION ON CINTERION PRODUCTS. THE SPECIFICATIONS IN THIS DOCUMENT ARE SUBJECT TO CHANGE AT CINTERION'S DISCRETION. CINTERION WIRELESS MODULES GMBH GRANTS A NON-EXCLUSIVE RIGHT TO USE THE PRODUCT. THE RECIPIENT SHALL NOT TRANSFER, COPY, MODIFY, TRANSLATE, REVERSE ENGINEER, CREATE DERIVATIVE WORKS; DISASSEMBLE OR DECOMPILE THE PRODUCT OR OTHERWISE USE THE PRODUCT EXCEPT AS SPECIFICALLY AUTHORIZED. THE PRODUCT AND THIS DOCUMENT ARE PROVIDED ON AN "AS IS" BASIS ONLY AND MAY CONTAIN DEFICIENCIES OR INADEQUACIES. TO THE MAXIMUM EXTENT PERMITTED BY APPLICABLE LAW, CINTERION WIRELESS MODULES GMBH DISCLAIMS ALL WARRANTIES AND LIABILITIES. THE RECIPIENT UNDERTAKES FOR AN UNLIMITED PERIOD OF TIME TO OBSERVE SECRECY REGARDING ANY INFORMATION AND DATA PROVIDED TO HIM IN THE CONTEXT OF THE DELIVERY OF THE PRODUCT. THIS GENERAL NOTE SHALL BE GOVERNED AND CONSTRUED ACCORDING TO GERMAN LAW.

**Copyright**

Transmittal, reproduction, dissemination and/or editing of this document as well as utilization of its contents and communication thereof to others without express authorization are prohibited. Offenders will be held liable for payment of damages. All rights created by patent grant or registration of a utility model or design patent are reserved.

Copyright © 2008, Cinterion Wireless Modules GmbH

**Trademark Notice**

Microsoft and Windows are either registered trademarks or trademarks of Microsoft Corporation in the United States and/or other countries. All other registered trademarks or trademarks mentioned in this document are property of their respective owners.

# Contents

<b>1. Introduction.....</b>	<b>11</b>
1.1 Scope of the document .....	11
1.2 Related documents .....	12
1.3 Document conventions.....	13
1.3.1 Quick reference table.....	13
1.3.2 Superscript notation for parameters and values .....	14
1.4 AT Command Syntax .....	15
1.4.1 Using Parameters .....	15
1.4.2 Combining AT commands on the same command line .....	16
1.5 Supported character sets .....	17
1.5.1 GSM alphabet tables and UCS2 character values .....	19
1.5.2 UCS2 and GSM data coding and conversion for SMS text mode .....	21
1.5.2.1 Implementing output of SIM data to Terminal (direction TA to TE) .....	21
1.5.2.2 Implementing input of Terminal data to SIM (direction TE to TA).....	22
1.6 Serial Interface Flow Control .....	23
1.6.1 Software Flow Control (XON/OFF Handshake).....	23
1.6.2 Hardware Flow Control (RTS/CTS Handshake).....	23
1.7 Unsolicited Result Code Presentation.....	24
1.7.1 Communication between Customer Application and TC35i .....	24
1.8 Errors and Messages .....	25
<b>2. Configuration Commands.....</b>	<b>26</b>
2.1 AT&F Set all current parameters to manufacturer defaults .....	26
2.2 AT&V Display current configuration .....	27
2.2.1 AT&V responses.....	28
2.3 AT&W Stores current configuration to user defined profile .....	30
2.4 ATQ Set result code presentation mode .....	31
2.5 ATV Set result code format mode .....	32
2.5.1 Verbose and numeric result codes .....	32
2.6 ATX Set CONNECT result code format and call monitoring .....	33
2.7 ATV Set CONNECT result code format .....	34
2.8 ATZ Set all current parameters to user defined profile.....	35
2.9 AT+CFUN Set phone functionality .....	36
2.9.1 Wake up the ME from SLEEP mode .....	39
2.10 AT^SMSO Switch off mobile station.....	41
2.11 AT+GCAP Request complete TA capabilities list.....	42
2.12 AT+CMEE Mobile Equipment Error Message Format .....	43
2.12.1 CME/CMS Error Code Overview .....	44
2.13 AT+CSCS Select TE character set .....	48
2.14 AT^SCFG Extended Configuration Settings .....	49
2.15 AT^SM20 Set M20 compatibility mode .....	56
<b>3. Status Control Commands .....</b>	<b>57</b>
3.1 AT+CMER Mobile Equipment Event Reporting .....	57
3.2 AT+CIND Indicator control .....	59
3.3 AT^SIND Extended Indicator Control.....	62

3.4	AT+CEER Extended Error Report.....	64
3.4.1	Cause Location ID for the extended error report .....	65
3.4.2	GSM release cause for L3 Radio Resource (RR).....	66
3.4.3	Proprietary release cause for L3 Radio Resource (RR).....	66
3.4.4	GSM release cause for Mobility Management (MM) or Session Management (SM)....	67
3.4.5	Proprietary release cause for L3 Mobility Management (MM) .....	68
3.4.6	GSM release cause for L3 Call Control (CC).....	68
3.4.7	Proprietary release cause for L3 Call Control (CC).....	69
3.4.8	Proprietary release cause for L3 Advice of Charge (AOC) .....	70
3.4.9	GSM Release cause for Supplementary Service Call .....	70
3.4.10	Proprietary release cause for Call-related Supplementary Services (CRSS) .....	71
3.5	ATS18 Extended call release report.....	73
3.6	AT+CPAS Mobile equipment activity status .....	75
3.7	AT+WS46 Select wireless network .....	76
<b>4.</b>	<b>Serial Interface Control Commands.....</b>	<b>77</b>
4.1	ATIQ Flowcontrol.....	77
4.2	AT&C Set circuit Data Carrier Detect (DCD) function mode .....	78
4.3	AT&D Set circuit Data Terminal Ready (DTR) function mode.....	79
4.4	AT%D Automatic Dial on DTR Line Activation .....	80
4.5	AT&S Set circuit Data Set Ready (DSR) function mode .....	82
4.6	ATE Enable command echo.....	83
4.7	AT+ICF Serial Interface Character Framing.....	84
4.8	AT+IFC Set Flow Control separately for data directions .....	86
4.9	AT+ILRR Set TE-TA local rate reporting .....	88
4.10	AT+IPR Set fixed local rate .....	90
4.10.1	Autobauding.....	91
4.11	AT+CMUX Enter multiplex mode .....	93
4.11.1	Restrictions on Multiplex mode.....	94
4.12	AT^STPB Transmit Parity Bit (for 7E1 and 7O1 only).....	96
<b>5.</b>	<b>Security Commands .....</b>	<b>97</b>
5.1	AT+CPIN PIN Authentication .....	97
5.1.1	What to do if PIN or password authentication fails? .....	99
5.2	AT+CPIN2 PIN2 Authentication .....	101
5.3	AT^SPIC Display PIN counter .....	103
5.4	AT+CLCK Facility lock .....	106
5.5	AT^SLCK Facility lock .....	111
5.6	AT+CPWD Change Password .....	112
5.7	AT^SPWD Change Password.....	116
<b>6.</b>	<b>Identification Commands.....</b>	<b>117</b>
6.1	ATI Display product identification information .....	117
6.2	AT+CGMI Request manufacturer identification.....	118
6.3	AT+GMI Request manufacturer identification .....	118
6.4	AT+CGMM Request model identification .....	119
6.5	AT+GMM Request model identification.....	119
6.6	AT+CGMR Request revision identification of software status.....	120
6.7	AT+GMR Request revision identification of software status .....	120
6.8	AT+CGSN Request International Mobile Equipment Identity (IMEI).....	121

6.9	AT+GSN	Request International Mobile Equipment Identity (IMEI)	121
6.10	AT+CIMI	Request International Mobile Subscriber Identity (IMSI)	122
<b>7.</b>	<b>Call related Commands</b>		<b>123</b>
7.1	ATA	Answer a call	123
7.2	ATD	Mobile originated call to specified number	124
7.3	ATD><mem><n>	Mobile originated call using specific memory and index number	126
7.4	ATD><n>	Mobile originated call from active memory using index number	128
7.5	ATD><str>	Mobile originated call from active memory using corresponding field	129
7.6	ATDI	Mobile originated call to ISDN number	130
7.7	ATDL	Redial last number used	131
7.8	ATH	Disconnect existing connection	132
7.9	AT+CHUP	Hang up call	133
7.10	AT^SHUP	Hang up call(s) indicating a specific GSM04.08 release cause	134
7.11	ATS0	Set number of rings before automatically answering a call	136
7.12	ATS6	Set pause before blind dialing	137
7.13	ATS7	Set number of seconds to wait for connection completion	138
7.14	ATS8	Set number of seconds to wait for comma dialing modifier	139
7.15	ATS10	Set disconnect delay after indicating the absence of data carrier	140
7.16	ATO	Switch from command mode to data mode	141
7.17	+++	Switch from data mode to command mode	142
7.18	AT+CBST	Select bearer service type	143
7.19	AT+CRLP	Select radio link protocol parameters for originated non-transparent data calls	144
7.20	AT+CLCC	List current calls of ME	145
7.21	AT+CR	Service reporting control	147
7.22	AT+CRC	Set Cellular Result Codes for incoming call indication	148
7.23	AT+CSNS	Single Numbering Scheme	149
7.24	AT^SCNI	List Call Number Information	150
7.25	AT^SLCD	Display Last Call Duration	151
7.26	AT^STCD	Display Total Call Duration	152
7.27	ATP	Select pulse dialing	153
7.28	ATT	Select tone dialing	153
<b>8.</b>	<b>Network Service Commands</b>		<b>154</b>
8.1	AT+COPN	Read operator names	154
8.2	AT+COPS	Operator Selection	155
8.3	AT+CREG	Network registration	158
8.4	AT+CSQ	Signal quality	161
8.5	AT^SMONC	Cell Monitoring	162
8.6	AT^SMOND	Cell Monitoring	164
8.7	AT^MONI	Monitor idle mode and dedicated mode	169
	8.7.1	AT^MONI responses	170
	8.7.2	Service states	171
8.8	AT^MONP	Monitor neighbour cells	172
	8.8.1	AT^MONP responses	173
8.9	AT^SALS	Alternate Line Service	174
8.10	AT^SHOM	Display Homezone	176
8.11	AT^SPLM	Read the PLMN list	177
8.12	AT^SPLR	Read entry from the preferred operators list	178
8.13	AT^SPLW	Write an entry to the preferred operators list	179

<b>9.</b>	<b>Supplementary Service Commands .....</b>	<b>180</b>
9.1	AT+CACM Accumulated call meter (ACM) reset or query .....	180
9.2	AT^SACM Advice of charge and query of ACM and ACMmax .....	181
9.3	AT+CAMM Accumulated call meter maximum (ACMmax) set or query.....	183
9.4	AT+CAOC Advice of Charge information .....	184
9.5	AT+CCUG Closed User Group .....	185
9.6	AT+CCFC Call forwarding number and conditions control .....	187
9.7	AT+CCWA Call Waiting .....	191
9.8	AT+CHLD Call Hold and Multiparty.....	195
9.9	AT+CLIP Calling line identification presentation .....	197
9.10	AT+CLIR Calling line identification restriction .....	199
9.11	AT+CPUC Price per unit and currency table.....	200
9.12	AT+CSSN Supplementary service notifications .....	202
9.13	AT+CUSD Supplementary service notifications.....	204
<b>10.</b>	<b>FAX Commands.....</b>	<b>206</b>
10.1	FAX parameters .....	206
10.1.1	Summary of Fax Class 2 URCs defined by EIA PN-2388 .....	208
10.2	AT+FBADLIN Bad Line Threshold .....	209
10.3	AT+FBADMUL Error Threshold Multiplier .....	210
10.4	AT+FBOR Query data Bit Order .....	211
10.5	AT+FCIG Query or set the Local Polling ID .....	212
10.6	AT+FCLASS Fax: Select, read or test service class.....	213
10.7	AT+FCQ Copy Quality Checking .....	214
10.8	AT+FCR Capability to Receive .....	215
10.9	AT+FDCC Query or set capabilities .....	216
10.10	AT+FDFFC Data Compression Format Conversion .....	217
10.11	AT+FDIS Query or set session parameters .....	218
10.12	AT+FDR Begin or continue phase C Data Reception .....	219
10.13	AT+FDT Data Transmission.....	220
10.14	AT+FET End a page or document .....	221
10.15	AT+FK Kill operation, orderly FAX abort.....	222
10.16	AT+FLID Query or set the Local Id setting capabilities .....	223
10.17	AT+FMDL Identify Product Model .....	224
10.18	AT+FMFR Request Manufacturer Identification.....	225
10.19	AT+FOPT Set bit Order independently .....	226
10.20	AT+FPHCTO DTE Phase C Response Timeout.....	227
10.21	AT+FREV Identify Product Revision .....	228
10.22	AT+FRH Receive Data Using HDLC Framing .....	229
10.23	AT+FRM Receive Data .....	230
10.24	AT+FRS Receive Silence.....	231
10.25	AT+FTH Transmit Data Using HDLC Framing.....	232
10.26	AT+FTM Transmit Data.....	233
10.27	AT+FTS Stop Transmission and Wait.....	234
10.28	AT+FVRFC Vertical Resolution Format Conversion .....	235
<b>11.</b>	<b>Short Message Service (SMS) Commands.....</b>	<b>236</b>
11.1	SMS parameters .....	236
11.2	AT+CMGC Send an SMS command.....	241
11.3	AT+CMGD Delete short message.....	242

11.4	AT+CMGF	Select SMS message format .....	243
11.5	AT+CMGL	List SMS messages from preferred store.....	244
11.6	AT+CMGR	Read SMS messages.....	246
11.7	AT+CMGS	Send Short Message .....	248
11.8	AT+CMGW	Write Short Messages to Memory .....	250
11.9	AT+CMSS	Send short messages from storage .....	252
11.10	AT+CNMA	New Message Acknowledgement to ME/TE, only phase 2+ .....	253
11.11	AT+CNMI	New SMS message indications.....	254
11.12	AT+CPMS	Preferred SMS message storage.....	257
11.13	AT+CSCA	SMS Service Center Address.....	259
11.14	AT+CSCB	Select Cell Broadcast Message Indication .....	260
11.15	AT+CSDH	Show SMS text mode parameters.....	261
11.16	AT+CSMP	Set SMS text Mode Parameters.....	262
11.17	AT+CSMS	Select Message Service.....	264
11.18	AT^SCML	List Concatenated Short Messages from preferred store .....	266
11.19	AT^SCMR	Read Concatenated Short Messages .....	267
11.20	AT^SCMS	Send Concatenated Short Messages.....	268
11.21	AT^SCMW	Write Concatenated Short Messages to Memory.....	269
11.22	AT^SLMS	List SMS Memory Storage .....	270
11.23	AT^SMGL	List Short Messages from preferred store without setting status to REC READ .....	271
11.24	AT^SMGO	Set or query SMS overflow presentation mode or query SMS overflow .....	272
11.25	AT^SMGR	Read short message without setting status to REC READ .....	274
11.26	AT^SSCONF	SMS Command Configuration .....	275
11.27	AT^SSDA	Set SMS Display Availability .....	276
11.28	AT^SSMSS	Set Short Message Storage Sequence .....	277
<b>12.</b>	<b>SIM related Commands</b> .....		<b>278</b>
12.1	AT+CRSM	Restricted SIM Access.....	278
12.2	AT^SCKS	Query SIM and Chip Card Holder Status .....	281
12.3	AT^SSET	Indicate SIM data ready.....	283
12.4	AT^SCID	Display SIM card identification number .....	284
12.5	AT+CXXCID	Display card ID.....	285
<b>13.</b>	<b>SIM Application Toolkit (SAT) Commands</b> .....		<b>286</b>
13.1	AT^SSTA	SAT Interface Activation .....	286
13.2	^SSTN	SAT Notification .....	288
13.3	AT^SSTGI	SAT Get Information .....	289
13.4	AT^SSTR	SAT Response .....	290
<b>14.</b>	<b>Phonebook Commands</b> .....		<b>291</b>
14.1		Sort Order for Phonebooks .....	291
14.2	AT+CPBR	Read from Phonebook.....	292
14.3	AT+CPBS	Select phonebook memory storage .....	295
14.4	AT+CPBW	Write into Phonebook .....	297
14.5	AT^SPBC	Find first matching entry in sorted phonebook .....	300
14.6	AT^SPBD	Purge phonebook memory storage.....	301
14.7	AT^SPBG	Display phonebook entries in alphabetical order .....	302
14.8	AT^SPBS	Step through the selected phonebook alphabetically.....	304
14.9	AT^SDLD	Delete the 'last number redial' memory .....	307

<b>15. Audio Commands</b>	<b>308</b>
15.1 Audio programming model	308
15.2 ATL Set monitor speaker loudness	309
15.3 ATM Set monitor speaker mode	309
15.4 AT+CLVL Loudspeaker volume level	310
15.5 AT+CMUT Mute control	311
15.6 AT+VTD Tone duration	312
15.7 AT+VTS DTMF and tone generation	313
15.8 AT^SAIC Audio Interface Configuration	314
15.9 AT^SNFA Set or query of microphone attenuation	316
15.10 AT^SNFD Set audio parameters to manufacturer default values	318
15.11 AT^SNFG Generate Tone	319
15.12 AT^SNFI Set microphone path parameters	321
15.13 AT^SNFM Mute microphone	322
15.14 AT^SNFO Set audio output (= loudspeaker path) parameter	323
15.15 AT^SNFPT Set progress tones	325
15.16 AT^SNFS Select audio hardware set	326
15.17 AT^SNFV Set loudspeaker volume	329
15.18 AT^SNFW Write audio setting in non-volatile store	330
15.19 AT^SRTC Ring tone configuration	331
<b>16. Hardware related Commands</b>	<b>333</b>
16.1 AT+CALA Set alarm time	333
16.2 AT+CCLK Real Time Clock	336
16.3 AT^SBC Battery charging / discharging and charge control	337
16.4 AT^SBV Battery/Supply Voltage	340
16.5 AT^SCTM Set critical operating temperature presentation mode or query temperature	341
16.6 AT^SSYNC Configure SYNC Pin	344
16.6.1 ME status indicated by status LED patterns	345
<b>17. Miscellaneous Commands</b>	<b>347</b>
17.1 A/ Repeat previous command line	347
17.2 ATS3 Set command line termination character	348
17.3 ATS4 Set response formatting character	349
17.4 ATS5 Write command line editing character	350
<b>18. Appendix</b>	<b>351</b>
18.1 Restricted access to SIM data after SIM PIN authentication	351
18.2 Star-Hash (*#) Network Commands	352
18.3 Available AT Commands and Dependency on SIM PIN	355
18.4 Availability of AT Commands Depending on Operating Mode of ME	361
18.5 AT Command Settings storable with AT&W	367
18.6 Factory Default Settings Restorable with AT&F	370
18.7 Summary of Unsolicited Result Codes (URC)	372
18.8 Alphabetical List of AT Commands	374



## List of Tables

Table 1.1:	Product specific use of AT commands .....	11
Table 1.2:	Symbols used to mark the type of parameters .....	14
Table 1.3:	Symbols used to indicate the correlations with other commands .....	14
Table 1.4:	Symbols used to mark different types of default values of parameters .....	14
Table 1.5:	Types of AT commands and responses .....	15
Table 1.6:	Examples for character definitions depending on alphabet .....	18
Table 2.1:	Current configuration on ASC0 / MUX channel 1 (example) .....	28
Table 2.2:	Current configuration on MUX channels 2 and 3 (example) .....	29
Table 2.3:	Wake-up events in NON-CYCLIC and CYCLIC SLEEP modes .....	39
Table 2.4:	General "CME ERROR" Codes (GSM 07.07) ..	44
Table 2.5:	SMS related "CMS ERROR" Codes (GSM 07.05) ..	45
Table 4.1:	Availability of AT Commands on Virtual Channels .....	94
Table 4.2:	Summary of AT commands with Different Behavior in Multiplex Mode .....	95
Table 10.1:	Summary of Fax Class 2 URCs defined by EIA PN-2388 .....	208
Table 16.1:	Modes of the LED and indicated ME functions .....	345
Table 18.1:	Star-Hash (*#) Command Overview .....	352
Table 18.2:	Abbreviations of Codes and Parameters used in Table 18.1 ...	353
Table 18.3:	Star-Hash Command Response Parameters .....	354
Table 18.4:	Star-Hash Commands for Supplementary Services .....	354
Table 18.5:	Available AT Commands and Dependency on SIM PIN.....	355
Table 18.6:	Availability of AT Commands Depending on Operating Mode of ME .....	361
Table 18.7:	Settings Stored to User Profile on ASC0 / MUX Channel 1.....	367
Table 18.8:	Settings Stored to User Profile on MUX Channels 2 and 3 .....	368
Table 18.9:	Factory Default Settings Restorable with AT&F .....	370
Table 18.10:	Summary of Unsolicited Result Codes (URC).....	372
Table 18.11:	Alphabetical List of AT Commands.....	374

---

## List of Figures

Figure 1.1:	Main character table of GSM 03.38 alphabet .....	19
Figure 1.2:	Extension character table of GSM 03.38 alphabet .....	20
Figure 15.1:	Audio programming model.....	308

# 1. Introduction

## 1.1 Scope of the document

This document presents the AT Command Set for  
*TC35i Module, Release 03.01*  
*TC35i Terminal, Release 03.01.*

Before using the Cellular Engine or upgrading to a new firmware version please read the latest product information provided in the Release Notes [1].

More information is available at <http://www.cinterion.com>.

If features differ between the *TC35i Module* and the *TC35i Terminal* this is noted in the section that refers to the AT command. At present the following features are concerned:

**Table 1.1:** Product specific use of AT commands

AT command	TC35i Module	TC35i Terminal
<a href="#">AT+ILRR</a>	Maximum bit rate: 230400 bps	Maximum bit rate: 115200 bps
<a href="#">AT+IPR</a>	Maximum bit rate: 230400 bps	Maximum bit rate: 115200 bps
<a href="#">AT+CALA</a>	Alarm mode and reminder message fully applicable	Does not support Alarm mode. Please ignore any information relating to the subject. The reminder message can be used as described.
<a href="#">AT^SAIC</a>	TC35i Module has three audio interfaces. All parameters are usable as described.	TC35i Terminal has one analog audio interface. See settings specific to TC35i Terminal.
<a href="#">AT^SSYNC</a>	SYNC pin may be assigned different functions: <mode> 0, 1 or 2. Delivery default is <mode>=0.	SYNC pin is only intended to drive the LED of the TC35i Terminal and supports only <mode>=1 or 2. Delivery default is <mode>=1.
<a href="#">AT^SBC</a>	All functions fully applicable	Command not applicable.

## 1.2 Related documents

- [1] TC35i Release Notes, Version 03.01
- [2] TC35i Hardware Interface Description, Version 03.01
- [3] TC35i Terminal Hardware Interface Description
- [4] Remote-SAT User's Guide
- [5] Multiplexer User's Guide
- [6] Multiplex Driver Developer's Guide for Windows 2000 and Windows XP
- [7] Multiplex Driver Installation Guide for Windows 2000 and Windows XP
- [8] Application Note 02: Audio Interface Design
- [9] Application Note 16: Updating TC35i Firmware
- [10] Application Note 24: Application Developer's Guide
- [11] ISO/IEC10646: "Universal Multiple-Octet Coded Character Set (UCS)"; UCS2, 16 bit coding
- [12] ITU-T Recommendation V.24: List of definitions for interchange circuits between data terminal equipment (DTE) and data circuit-terminating equipment (DCE)
- [13] ITU-T Recommendation V.250: Serial asynchronous automatic dialling and control
- [14] 3GPP TS 100 918/EN 300 918 (GSM 02.04): General on supplementary services
- [15] 3GPP TS 100 907 (GSM 02.30): Man-Machine Interface (MMI) of the Mobile Station (MS)
- [16] 3GPP TS 23.038 (GSM 03.38): Alphabets and language specific information
- [17] 3GPP TS 27.005 (GSM 07.05): Use of Data Terminal Equipment - Data Circuitterminating Equipment (DTE - DCE) interface for Short Message Service (SMS) and Cell Broadcast Service (CBS)
- [18] 3GPP TS 27.007 (GSM 07.07): AT command set for User Equipment (UE)
- [19] 3GPP TS 27.060 (GSM 07.60): Mobile Station (MS) supporting Packet Switched Services
- [20] 3GPP TS 51.011 (GSM 11.11): Specification of the Subscriber Identity Module - Mobile Equipment (SIM - ME) interface
- [21] 3GPP TS 11.14 (GSM 11.14): Specification of the SIM Application Toolkit for the Subscriber Identity Module - Mobile Equipment (SIM - ME) interface

## 1.3 Document conventions

Throughout the document, the GSM engines are referred to as ME (Mobile Equipment), MS (Mobile Station), TA (Terminal Adapter), DCE (Data Communication Equipment) or facsimile DCE (FAX modem, FAX board). When the Cinterion Wireless Modules product names are required to distinguish the two models, TC35i is short for the engine type and TC35iT for the terminal.

To control your GSM engine you can simply send AT Commands via its serial interface. The controlling device at the other end of the serial line is referred to as TE (Terminal Equipment), DTE (Data Terminal Equipment) or plainly 'the application' (probably running on an embedded system).

All abbreviations and acronyms used throughout this document are based on the GSM specifications. For definitions please refer to TR 100 350 V7.0.0 (1999-08), (GSM 01.04, version 7.0.0 release 1998).

### 1.3.1 Quick reference table

Each AT command description includes a table similar to the example shown below. The table is intended as a quick reference to indicate the following functions:

- PIN: Is the AT command PIN protected?
  - Yes
  - No
  - Usage is dependent on conditions specified for the command, or not all command types are PIN protected (for example write command PIN protected, read command not).

Note: The table provided in Section [18.3, Available AT Commands and Dependency on SIM PIN](#) uses the same symbols.
- ASC0: Is the AT command supported on the physical serial interface ASC0?
  - Yes
  - No

Note: In the case of TC35i only "Yes" applies.
- MUXn: Is the AT command usable on the Multiplexer channels MUX1, MUX2, MUX3?
  - Yes
  - No
  - AT command is usable, but under the restrictions specified in the section related to the command.

Note: The columns MUX1, MUX2 and MUX3 are relevant only when the GSM engine operates in Multiplexer mode, that is, when the physical serial interface is partitioned into 3 virtual channels by using the Multiplexer protocol. Usage is the same on ASC0 and MUX1.
- Is the AT command supported in ALARM mode?
  - Yes
  - No
- Charge: Is the AT command supported in CHARGE ONLY mode?
  - Yes
  - No
  - AT command is usable, but under the restrictions specified in the section related to the command.
- Last: If commands are concatenated, this AT command must be the last one.
  - Yes
  - No

Note: See also Section [1.4, AT Command Syntax](#) for details on concatenated AT commands.

Example:

PIN	ASC0	MUX1	MUX2	MUX3	Charge		Last
<input type="radio"/>	<input checked="" type="radio"/>	<input checked="" type="radio"/>	<input checked="" type="radio"/>	<input checked="" type="radio"/>	<input checked="" type="radio"/>	<input type="radio"/>	<input type="radio"/>

## 1.3.2 Superscript notation for parameters and values

**Table 1.2:** Symbols used to mark the type of parameters

Parameter type	Meaning
<param> <sup>(num)</sup>	Parameter value must be numeric type
<param> <sup>(str)</sup>	Parameter value must be string type

**Table 1.3:** Symbols used to indicate the correlations with other commands

Parameter option	Meaning
<param> <sup>(&amp;W)</sup>	Parameter value will be stored with <a href="#">AT&amp;W</a>
<param> <sup>(&amp;V)</sup>	Parameter value will be displayed with <a href="#">AT&amp;V</a>
<param> <sup>(^SNFW)</sup>	Parameter value will be stored with <a href="#">AT^SNFW</a>
<param> <sup>(+CSCS)</sup>	Parameter value has to be (is) coded according to current setting of <a href="#">&lt;chset&gt;</a> (see <a href="#">AT+CSCS</a> for details)

**Table 1.4:** Symbols used to mark different types of default values of parameters

Value option	Meaning
[x]	Default value: if the parameter is omitted, the value 'x' will be assumed
x <sup>(&amp;F)</sup>	Factory default value, will be restored to 'x' with <a href="#">AT&amp;F</a>
x <sup>(P)</sup>	Powerup default value of a parameter which is not stored at power down
x <sup>(D)</sup>	Delivery default value of a parameter which cannot be restored automatically

## 1.4 AT Command Syntax

The "AT" or "at" prefix must be set at the beginning of each command line. To terminate a command line enter <CR>. Commands are usually followed by a response that includes "<CR><LF><response><CR><LF>". Throughout this document, only the responses are presented, <CR><LF> are omitted intentionally.

**Table 1.5:** Types of AT commands and responses

AT command type	Syntax	Function
Test command	AT+CXXX=?	The mobile equipment returns the list of parameters and value ranges set with the corresponding Write command or by internal processes.
Read command	AT+CXXX?	This command returns the currently set value of the parameter or parameters.
Write command	AT+CXXX=<...>	This command sets user-definable parameter values.
Exec(ution) command	AT+CXXX	The execution command reads non-variable parameters determined by internal processes in the GSM engine.

### 1.4.1 Using Parameters

- Optional parameters are enclosed in square brackets. If optional parameters are omitted, the current settings are used until you change them.
- Optional parameters or subparameters can be omitted unless they are followed by other parameters. If you want to omit a parameter in the middle of a string it must be replaced by a comma. See also example 1.
- A parameter value enclosed in square brackets represents the value that will be used if an optional parameter is omitted. See also example 2.
- When the parameter is a character string, e.g. <text> or <number>, the string must be enclosed in quotation marks, e.g. "Charlie Brown" or "+49030xxxx". Symbols in quotation marks will be recognized as strings.
- All spaces will be ignored when using strings without quotation marks.
- It is possible to omit the leading zeros of strings which represent numbers.
- If an optional parameter of a V.250 command is omitted, its value is assumed to be 0.

Example 1: Omitting parameters in the middle of a string

AT+CCUG?	Query current setting
+CCUG: 1,10,1	
OK	
AT+CCUG=,9	Set only the middle parameter
OK	
AT+CCUG?	Query new setting
+CCUG: 1,9,1	
OK	

Example 2: Using default parameter values for optional parameters

AT+CFUN=5	Activate CYCLIC SLEEP mode, don't reset ME
OK	
AT+CFUN?	Query ME mode
+CFUN: 5	
OK	
AT+CFUN=	Set ME back to normal (default parameters: 1,0)
OK	
+CFUN: 1	
OK	

## 1.4.2 Combining AT commands on the same command line

You may enter several AT commands on the same line. This eliminates the need to type the "AT" or "at" prefix before each command. Instead, it is only needed once at the beginning of the command line. Use a semicolon as command delimiter.

The table below lists the AT commands you cannot enter together with other commands on the same line. Otherwise, the responses may not be in the expected order.

AT command type	Comment
V.250 commands	with FAX commands (Prefix AT+F)
GSM 7.07 commands	with proprietary commands, Prefix AT^S)
GSM 7.05 commands (SMS)	To be used standalone
Commands starting with AT&	To be used standalone
<a href="#">AT+IPR</a>	To be used standalone

Note: When concatenating AT commands please keep in mind that the sequence of processing may be different from the sequential order of command input. Therefore, if the consecutive order of the issued commands and the associated responses is your concern, avoid concatenating commands on the same line.



## 1.5 Supported character sets

The ME supports two character sets: GSM 03.38 (7 bit, also referred to as GSM alphabet or SMS alphabet) and UCS2 (16 bit, refer to ISO/IEC 10646). See [AT+CSCS](#) for information about selecting the character set. Character tables can be found below.

### Explanation of terms

- International Reference Alphabet (IRA)  
IRA means that one byte is displayed as two characters in hexadecimal format. For example, the byte 0x36 (decimal 54) is displayed as "36" (two characters). IRA is used here for input 8-bit or 16-bit data via terminal devices using text mode. This means only characters 'A'..'F', 'a'..'f' and '0'..'9' are valid.
- Escape sequences  
The escape sequence used within a text coded in the GSM default alphabet (0x1B) must be correctly interpreted by the TE, both for character input and output. To the module, an escape sequence appears like any other byte received or sent.
- Terminal Adapter (TA)  
TA is used equivalent to Mobile Equipment (ME) which stands for the GSM module described here. It uses GSM default alphabet as its character set.
- Terminal Equipment (TE)  
TE is the device connected to the TA via serial interface. In most cases TE is an ANSI/ASCII terminal that does not fully support the GSM default alphabet, for example MS Hyperterminal.
- TE Character Set  
The character set currently used by Terminal Equipment is selected with [AT+CSCS](#).
- Data Coding Scheme (dcs)  
DCS is part of a short message and is saved on the SIM. When writing a short message to the SIM in text mode, the dcs stored with [AT+CSMP](#) is used and determines the coded character set.

The behavior when encountering characters, that are not valid characters of the supported alphabets, is undefined.

Due to the constraints described below it is recommended to prefer the USC2 alphabet in any external application.

If the GSM alphabet is selected all characters sent over the serial line (between TE and TA) are in the range from 0 to 127 (7 Bit range). CAUTION: ASCII alphabet (TE) is not GSM alphabet (TA/ME) !

Several problems resulting from the use of GSM alphabet with ASCII terminal equipment:

- "@" character with GSM alphabet value 0 is not printable by an ASCII terminal program (e.g. Microsoft® Hyperterminal®).
- "@" character with GSM alphabet value 0 will terminate any C string! This is because the 0 is defined as C string end tag. Therefore, the GSM Null character may cause problems on application level when using a 'C'-function as "strlen()". This can be avoided if it is represented by an escape sequence as shown in the table below.  
By the way, this may be the reason why even network providers often replace "@" with "@=" in their SIM application.
- Other characters of the GSM alphabet are misinterpreted by an ASCII terminal program. For example, GSM "ö" (as in "Börse") is assumed to be "l" in ASCII, thus resulting in "B|rse". This is because both alphabets mean different characters with values hex. 7C or 00 and so on.
- In addition, decimal 17 and 19 which are used as XON/XOFF control characters when software flow control is activated, are interpreted as normal characters in the GSM alphabet.

When you write characters differently coded in ASCII and GSM (e.g. Ä, Ö, Ü), you need to enter escape sequences. Such a character is translated into the corresponding GSM character value and, when output later, the GSM character value can be presented. Any ASCII terminal then will show wrong responses.

**Table 1.6:** Examples for character definitions depending on alphabet

GSM 03.38 character	GSM character hex. value	Corresponding ASCII character	ASCII Esc sequence	Hex Esc sequence
Ö	5C	\	\5C	5C 35 43
"	22	"	\22	5C 32 32
ò	08	BSP	\08	5C 30 38
@	00	NULL	\00	5C 30 30

CAUTION: Often, the editors of terminal programs do not recognize escape sequences. In this case, an escape sequence will be handled as normal characters. The most common workaround to this problem is to write a script which includes a decimal code instead of an escape sequence. This way you can write, for example, short messages which may contain differently coded characters.

### 1.5.1 GSM alphabet tables and UCS2 character values

This section provides tables for the GSM 03.38 alphabet supported by the ME. Below any GSM character find the corresponding two byte character value of the UCS2 alphabet.

Main character table of GSM 03.38 alphabet				b7	0	0	0	0	1	1	1	1
				b6	0	0	1	1	0	0	1	1
				b5	0	1	0	1	0	1	0	1
b4	b3	b2	b1		0	1	2	3	4	5	6	7
0	0	0	0	0	@ 0040	0394	SP 0020	0 0030	i 00A1	P 0050	z 00BF	p 0070
0	0	0	1	1	£ 00A3	_ 005F	! 0021	1 0031	A 0041	Q 0051	a 0061	q 0071
0	0	1	0	2	\$ 0024	03A6	" 0022	2 0032	B 0042	R 0052	b 0062	r 0072
0	0	1	1	3	¥ 00A5	0393	# 0023	3 0033	C 0043	S 0053	c 0063	s 0073
0	1	0	0	4	è 00E8	039B	¤ 00A4	4 0034	D 0044	T 0054	d 0064	t 0074
0	1	0	1	5	é 00E9	03A9	% 0025	5 0035	E 0045	U 0055	e 0065	u 0075
0	1	1	0	6	ù 00F9	03A0	& 0026	6 0036	F 0046	V 0056	f 0066	v 0076
0	1	1	1	7	ì 00EC	03A8	' 0027	7 0037	G 0047	W 0057	g 0067	w 0077
1	0	0	0	8	ò 00F2	03A3	( 0028	8 0038	H 0048	X 0058	h 0068	x 0078
1	0	0	1	9	ç 00C7	0398	) 0029	9 0039	I 0049	Y 0059	i 0069	y 0079
1	0	1	0	10 /A	LF [LF] <sup>2)</sup>	039E	* 002A	: 003A	J 004A	Z 005A	j 006A	z 007A
1	0	1	1	11 /B	ø 00D8	<sup>1)</sup>	+ 002B	; 003B	K 004B	Ä 00C4	k 006B	ä 00E4
1	1	0	0	12 /C	ø 00F8	Æ 00C6	, 002C	< 003C	L 004C	Ö 00D6	l 006C	ö 00F6
1	1	0	1	13 /D	CR [CR] <sup>2)</sup>	æ 00E6	- 002D	= 003D	M 004D	Ñ 00D1	m 006D	ñ 00F1
1	1	1	0	14 /E	À 00C5	ß 00DF	. 002E	> 003E	N 004E	Ü 00DC	n 006E	ü 00FC
1	1	1	1	15 /F	à 00E5	É 00C9	/ 002F	? 003F	O 004F	Ş 00A7	o 006F	à 00E0

Figure 1.1: Main character table of GSM 03.38 alphabet

- 1) This code is an escape to the following extension of the 7 bit default alphabet table.
- 2) This code is not a printable character and therefore not defined for the UCS2 alphabet. It shall be treated as the accompanying control character.

Extension character table of GSM 03.38 alphabet				b7	0	0	0	0	1	1	1	1
				b6	0	0	1	1	0	0	1	1
				b5	0	1	0	1	0	1	0	1
b4	b3	b2	b1		0	1	2	3	4	5	6	7
0	0	0	0	0					 007C			
0	0	0	1	1								
0	0	1	0	2								
0	0	1	1	3								
0	1	0	0	4		^ 005E						
0	1	0	1	5						€ <sup>2</sup> 20AC		
0	1	1	0	6								
0	1	1	1	7								
1	0	0	0	8			{ 007B					
1	0	0	1	9			} 007D					
1	0	1	0	10 /A	↵ [LF]							
1	0	1	1	11 /B	↵							
1	1	0	0	12 /C			[ 005B					
1	1	0	1	13 /D			~ 007E					
1	1	1	0	14 /E			] 005D					
1	1	1	1	15 /F			\ 005C					

Figure 1.2: Extension character table of GSM 03.38 alphabet

- 1) This code value is reserved for the extension to another extension table. On receipt of this code, a receiving entity shall display a space until another extension table is defined.
- 2) This code represents the EURO currency symbol. The code value is the one used for the character 'e'. Therefore a receiving entity which is incapable of displaying the EURO currency symbol will display the character 'e' instead.
- 3) This code is defined as a Page Break character and may be used for example in compressed CBS messages. Any mobile which does not understand the 7 bit default alphabet table extension mechanism will treat this character as Line Feed.

In the event that an MS receives a code where a symbol is not represented in Figure 1.2, [Extension character table of GSM 03.38 alphabet](#) the MS shall display the character shown in the main default 7 bit alphabet table (see Figure 1.1, [Main character table of GSM 03.38 alphabet](#)).

## 1.5.2 UCS2 and GSM data coding and conversion for SMS text mode

This section provides basic information on how to handle input and output character conversion for SMS text mode and Remote-SAT if internal (TA) and external (TE) character representation differ, i.e. if the Data Coding Scheme and the TE character use different coding.

### 1.5.2.1 Implementing output of SIM data to Terminal (direction TA to TE)

Used character set	DCS = 7 bit GSM	DCS = 8 bit Data	DCS = 16 bit UCS2
GSM	Case 1 GSM (1:1)	Case 2 8 bit to IRA (1:2)	Case 3 UCS2 to IRA (2:4)
UCS2	Case 4 GSM to IRA (1:4)	Case 5 8 bit to IRA (1:4)	Case 6 UCS2 to IRA (2:4)

Note: The ratio of SIM bytes to output bytes is given in parentheses.

#### Case 1

Every GSM character is sent to the TE as it is (8-bit value with highest bit set to zero).

Example: 47'H, 53'H, 4D'H → 47'H, 53'H, 4D'H, displayed as "GSM"

#### Case 2

Every data byte is sent to the TE as 2 IRA characters each representing a halfbyte.

Example: B8'H (184 decimal) → 42'H, 38'H, displayed as "B8"

#### Case 3

Every 16-bit UCS2 value is sent to the TE as 4 IRA characters.

Example: C4xA7'H (50343 decimal) → 43'H, 34'H, 41'H, 37'H, displayed as "C4A7"

Problem: An odd number of bytes leads to an error because there are always two bytes needed for each USC2 character

#### Case 4

Every GSM character is sent to the TE as 4 IRA characters to show UCS2 in text mode.

Example: 41'H ("A") → 30'H, 30'H, 34'H, 31'H, displayed as "0041"

#### Case 5

Every data byte is sent to the TE as IRA representation of UCS2 (similar to case 4).

Example: B2'H → 30'H, 30'H, 42'H, 32'H, displayed as "00B2"

#### Case 6

Every 16-bit value is sent to the TE as IRA representation of it. It is assumed that number of bytes is even.

Example: C3x46'H → 43'H, 33'H, 34'H, 36'H, displayed as "C346"

### 1.5.2.2 Implementing input of Terminal data to SIM (direction TE to TA)

Used character set	DCS = 7 bit GSM	DCS = 8 bit Data	DCS = 16 bit UCS2
GSM	Case 1 GSM (1:1)	Case 2 IRA to 8 bit (2:1)	Case 3 IRA to 16 bit (4:2)
UCS2	Case 4 UCS2 to GSM (4:1)	Case 5 UCS2 to 8 bit (4:1)	Case 6 UCS2 to 16 bit (4:2)

Note: The ratio between the number of input characters and bytes stored on the SIM is given in parentheses.

#### Case 1

Every character is sent from TE to TA as GSM character (or ASCII with standard terminal emulation, e.g. Hyper-terminal).

Character value must be in range from 0 to 127 because of 7-bit GSM alphabet.

To reach maximum SMS text length of 160 characters in 140 bytes space characters will be compressed on SIM. This must be set using the parameter `<dcsc>` of `AT+CSMP` (add 64).

Example: "ABCDEFGH" typed is sent and stored uncompressed as → 4142434445464748'H (stored compressed as 41E19058341E91'H)

#### Case 2

Every data byte is sent as 2 IRA characters.

Maximum text length is 280 IRA characters which will be converted into 140 bytes SMS binary user data

Example: "C8" typed is sent as 43'H, 38'H → stored as C8'H

#### Case 3

Every 16-bit value is sent as 4 IRA characters.

Maximum text length is 280 IRA characters which will be converted into 70 UCS2 characters (16-bit each)

Number of IRA characters must be a multiple of four because always 4 half bytes are needed for a 16-bit value

Example: "D2C8" typed is sent as 44'H, 32'H, 43'H, 38'H → stored as D2C8'H

#### Case 4

Every GSM character is sent as 4 IRA characters representing one UCS2 character.

Example: To store text "ABC" using UCS2 character set you have to type "004100420043".

This is sent as 30'H,30'H,34'H,31'H, 30'H,30'H,34'H,32'H, 30'H,30'H,34'H,33'H → detected as IRA representation of 3 UCS2 characters, converted to GSM character set and stored as 41'H, 42'H, 43'H.

Maximum input is 640 IRA characters representing 160 UCS2 characters when compression is active. These are converted to 160 GSM 7-bit characters.

Without compression only 140 GSM characters can be stored which are put in as 560 IRA characters.

Values of UCS2 characters must be smaller than 80'H (128 decimal) to be valid GSM characters.

Number of IRA characters must be a multiple of four. Problems:

- "41" → Error, there are four IRA characters (two bytes) needed
- "0000" → Error, not an UCS2 character
- "4142" → Error, value of UCS2 character > 7F'H
- "008B" → Error, value of UCS2 character > 7F'H

This affects the maximum input length of a string)

#### Case 5

Every UCS2 character is sent as 4 IRA characters and is converted into two 8-bit values. This means that the first two characters have to be '00'.

Example: UCS2 character 009F'H typed as "009F" is sent as 30'H,30'H,39'H,46'H → converted into 8-bit value 9F'H.

Maximum number of UCS2 characters is 140 which are represented by 560 IRA characters. Number of IRA characters must be a multiple of four.

#### Case 6

Every UCS2 character is sent as 4 IRA characters each and is converted into a 16-bit value again.

Example: UCS2 character 9F3A'H typed as "9F3A" is sent as 39'H,46'H,33'H,41'H → converted into 9F3A'H.

Maximum number of UCS2 characters is 70 which are represented by 280 IRA characters. Number of IRA characters must be a multiple of four.

Invalid UCS2 values must be prevented.

## 1.6 Serial Interface Flow Control

Flow control is essential to prevent loss of data or avoid errors when, in a data or fax call, the sending device is transferring data faster than the receiving side is ready to accept. When the receiving buffer reaches its capacity, the receiving device should be capable to cause the sending device to pause until it catches up.

There are basically two approaches to regulate data flow: Software flow control and hardware flow control. The High Watermark of the input/output buffer should be set to approximately 60% of the total buffer size. The Low Watermark is recommended to be about 30%. The data flow should be stopped when the capacity rises close to the High Watermark and resumed when it drops below the Low Watermark. The time required to cause stop and go results in a hysteresis between the High and Low Watermarks.

During Multiplex mode ([AT+CMUX](#)) it is recommended to use hardware flow control.

### 1.6.1 Software Flow Control (XON/OFF Handshake)

Software flow control sends different characters to stop (XOFF, decimal 19) and resume (XON, decimal 17) data flow. The only advantage of software flow control is that three wires would be sufficient on the serial interface.

### 1.6.2 Hardware Flow Control (RTS/CTS Handshake)

Hardware flow control sets or resets the RTS/CTS wires. This approach is faster and more reliable, and therefore, the better choice. When the High Watermark is reached, CTS is set inactive until the transfer from the buffer has completed. When the Low Watermark is passed, CTS goes active again.

To achieve smooth data flow, ensure that the RTS/CTS lines are present on your application platform. The application should include options to enable RTS/CTS handshake with the GSM engine. This needs to be done with the AT command [AT\Q3](#) - it is not sufficient to set RTS/CTS handshake in the used Terminal program only.

The default setting of the GSM engine is [AT\Q0](#) (no flow control) which must be altered to [AT\Q3](#) (RTS/CTS hardware handshake on). The setting is stored volatile and must be restored each time after the GSM engine was switched off.

[AT\Q](#) has no read command. To verify the current setting of [AT\Q](#), simply check the settings of the active profile with [AT&V](#).

Often, fax programs run an initialization procedure when started up. The initialization commonly includes enabling RTS/CTS hardware handshake, eliminating the need to set [AT\Q3](#) once again. However, before setting up a CSD call, you are advised to check that RTS/CTS handshake is set.

RTS/CTS hardware handshake must also be set if you want to take advantage of the CYCLIC SLEEP modes. For further details refer to [AT+CFUN](#).

## 1.7 Unsolicited Result Code Presentation

URC stands for Unsolicited Result Code and is a report message issued by the ME without being requested by the TE, i.e. a URC is issued automatically when a certain event occurs. Hence, a URC is not issued as part of the response related to an executed AT command.

Typical events leading to URCs are incoming calls ("RING"), waiting calls, received short messages, changes in temperature, network registration etc.

A list of all URCs can be found in Section [18.7, Summary of Unsolicited Result Codes \(URC\)](#).

To announce a pending URC transmission the ME will do the following:

- The ME activates its RING line (logic "1") for 1 second, i.e. the RING line changes to the physical "Low" level. This allows the TE to stay in power saving mode until an ME related event requests service. If several URCs occur coincidentally or in quick succession each URC triggers the RING line independently, although the line will not be deactivated between each URC. As a result, the RING line may stay low for more than 1 second. If an incoming call is answered within less than 1 second (with [ATA](#) or if autoanswering is set to [ATS0=1](#)) then the RING line will be deactivated earlier. The "[^SHUTDOWN](#)" URC will not activate the RING line.
- If the AT command interface is busy a "BREAK" will be sent immediately but the URC will not be issued until the line is free. This may happen if the URC is pending in the following cases:
  - During the processing of an AT command (i.e. the time after the TE echoes back the first character "A" of an AT command just sent by itself until the ME responds with "OK" or "ERROR").
  - During a data call.

Please note that AT command settings may be necessary to enable in-band signaling, e.g. refer to [AT+CMER](#) or [AT+CNMI](#).

It is strongly recommended to use the multiplex mode to map logical communication channels onto the serial line of the TC35i, for details refer to [\[5\]](#) and AT command [AT+CMUX](#). Doing so it is possible to use one channel to still process URCs while having a data call active on another.

For most of these messages, the ME needs to be configured whether or not to send a URC. Depending on the AT command, the URC presentation mode can be saved to the user defined profile (see [AT&W](#)), or needs to be activated every time you reboot the ME. Several URCs are not user definable, such as "[^SYSSTART](#)", "[^SYSSTART <text>](#)", "[^SHUTDOWN](#)" and the Fax Class 2 URCs listed in Section [10.1, FAX parameters](#).

If autobauding is enabled (as factory default mode or set with [AT+IPR=0](#)), URCs generated after restart will be output with 57600 bps until the ME has detected the current bit rate. The URCs "[^SYSSTART](#)", "[^SYSSTART <text>](#)", however, are not presented at all. For details please refer to Section [4.10.1, Autobauding](#). To avoid problems we recommend to configure a fixed bit rate rather than using autobauding.

### 1.7.1 Communication between Customer Application and TC35i

Leaving hardware flow control unconsidered the Customer Application (TE) is coupled with the TC35i (ME) via a receive and a transmit line.

Since both lines are driven by independent devices collisions may (and will) happen, i.e. while the TE issues an AT command the TC35i starts sending an URC. This will probably lead to the TE's misinterpretation of the URC being part of the AT command's response.

To avoid this conflict the following measures must be taken:

- If an AT command is finished (with "OK" or "ERROR") the TE shall always wait at least 100 milliseconds before sending the next one. This gives the TC35i the opportunity to transmit pending URCs and get necessary service. Note that some AT commands may require more delay after "OK" or "ERROR" response, refer to the following command specifications for details.
- The TE shall communicate with the TC35i using activated echo ([ATE1](#)), i.e. the TC35i echoes characters received from the TE. Hence, when the TE receives the echo of the first character "A" of the AT command just sent by itself it has control both over the receive and the transmit paths.



---

## 1.8 Errors and Messages

The command result codes "+CME ERROR: <err>" and "+CMS ERROR: <err>" indicate errors related to mobile equipment or network functionality.

The format of <err> can be either numeric or verbose and is selectable via [AT+CMEE](#).

A result error code terminates the execution of the command and prevents the execution of all remaining commands that may follow on the same command line. If so, neither "ERROR" nor "OK" result codes are returned for these commands. A 30 seconds timeout will deliver "ERROR" when the input of a command is not complete.

Using the wrong command syntax may result in errors: For example, using the execute command syntax although the command has no execute format, causes "ERROR" to be returned. Likewise, using the write command syntax although the command has no write format causes "+CME ERROR: <err>" to be returned.

See also:

- Section [2.12.1](#), [CME/CMS Error Code Overview](#)
- Section [2.5.1](#), [Verbose and numeric result codes](#)
- Section [3.4](#), [AT+CEER](#)



## 2.2 AT&V Display current configuration

[AT&V](#) returns the current parameter setting. The configuration varies depending on whether or not PIN authentication has been done and whether or not Multiplex mode is enabled (see [AT+CMUX](#)).

### Syntax

```
Exec Command
AT&V[<value>]
Response(s)
ACTIVE PROFILE:
... (see Section 2.2.1, AT&V responses)
OK
```

Reference(s)	PIN	ASC0	MUX1	MUX2	MUX3	Charge		Last
V.250	<input type="radio"/>	<input checked="" type="radio"/>	<input checked="" type="radio"/>	<input type="radio"/>	<input type="radio"/>	<input type="radio"/>	<input type="radio"/>	<input type="radio"/>

### Parameter Description

<value><sup>(num)</sup>

[0] Profile number

### Notes

- The value of \Q (flow control) is also determined by the [AT+IFC](#) command. In case the value set by [AT+IFC](#) cannot be represented by a \Q equivalent, \Q255 will be displayed.
- The parameters of [AT^SMGO](#) can only be displayed after the SMS data from the SIM have been read successfully for the first time. Reading starts after successful SIM authentication has been performed, and may take up to 30 seconds depending on the SIM used. While the read process is in progress, an attempt to read the parameter will result in empty values.
- The parameter of [AT+CSDH](#) will only be displayed in SMS PDU mode, see [AT+CMGF](#).

## 2.2.1 AT&V responses

The following tables show four different kinds of responses depending on whether or not the PIN is entered and whether or not the Multiplex mode is enabled (see [AT+CMUX](#)).

**Table 2.1:** Current configuration on ASC0 / MUX channel 1 (example)

PIN authentication done	No PIN authentication
<pre>ACTIVE PROFILE: E1 Q0 V1 X4 &amp;C1 &amp;D2 &amp;S0 \Q0 \V1 S0:000 S3:013 S4:010 S5:008 S6:000 S7:060 S8:000 S10:002 S18:000 +CBST: 7,0,1 +CRLP: 61,61,78,6 +CR: 0 +FCLASS: 0 +CRC: 0 +CMGF: 1 +CSDH: 0 +CNMI: 0,0,0,0,1 +ICF: 3 +IFC: 0,0 +ILRR: 0 +IPR: 57600 +CMEE: 2 ^SMGO: 0,0 +CSMS: 0,1,1,1 ^SACM: 0,"000000","000000" ^SCKS: 0,1 ^SSET: 0 +CREG: 0,1 +CLIP: 0,2 +CAOC: 0 +COPS: 0,0,"operator" %D: 0 OK</pre>	<pre>ACTIVE PROFILE: E1 Q0 V1 X4 &amp;C1 &amp;D2 &amp;S0 \Q0 \V1 S0:000 S3:013 S4:010 S5:008 S6:000 S7:060 S8:000 S10:002 S18:000 +CBST: 7,0,1 +CRLP: 61,61,78,6 +CR: 0 +FCLASS: 0 +ICF: 3 +IFC: 0,0 +ILRR: 0 +IPR: 57600 +CMEE: 2 ^SCKS: 0,1 ^SSET: 0 OK</pre>

**Table 2.2:** Current configuration on MUX channels 2 and 3 (example)

PIN authentication done	No PIN authentication
<p>ACTIVE PROFILE:            E1 Q0 V1 X4 &amp;C1 &amp;D0 &amp;S0 \Q0            S0:000 S3:013 S4:010 S5:008            +CRC: 0            +CMGF: 1            +CSDH: 0            +CNMI: 0,0,0,0,1            +ICF: 3            +IFC: 0,0            +ILRR: 0            +IPR: 57600            +CMEE: 2            ^SMGO: 0,0            +CSMS: 0,1,1,1            ^SACM: 0,"000000","000000"            ^SCKS: 0,1            ^SSET: 0            +CREG: 0,1            +CLIP: 0,2            +CAOC: 0            +COPS: 0,0,"operator"            OK</p>	<p>ACTIVE PROFILE:            E1 Q0 V1 X4 &amp;C1 &amp;D0 &amp;S0 \Q0            S0:000 S3:013 S4:010 S5:008            +ICF: 3            +IFC: 0,0            +ILRR: 0            +IPR: 57600            +CMEE: 2            ^SCKS: 0,1            ^SSET: 0            OK</p>

## 2.3 AT&W Stores current configuration to user defined profile

AT&W stores the currently set parameters to a user defined profile in the non-volatile memory.

### Syntax

Exec Command									
AT&W[<value>]									
Response(s)									
OK									
ERROR/+CME ERROR <err>									
Reference(s)		PIN	ASC0	MUX1	MUX2	MUX3	Charge		Last
V.250		<input type="radio"/>	<input checked="" type="radio"/>	<input checked="" type="radio"/>	<input checked="" type="radio"/>	<input checked="" type="radio"/>	<input type="radio"/>	<input type="radio"/>	<input type="radio"/>

### Parameter Description

<value> <sup>(num)</sup>	
[0]	Number of profile

### Notes

- The user defined profile will be restored automatically after power-up. Use ATZ to restore user profile and AT&F to restore factory settings. Until the first use of AT&W, ATZ works as AT&F.
- AT&W stores all global settings and the current local settings of the interface, on which the command is executed.
- A list of parameters stored to the user profile can be found in Section 18.5, AT Command Settings storable with AT&W.

## 2.4 ATQ Set result code presentation mode

This parameter setting determines whether or not the TA transmits any result code to the TE. Information text transmitted in response is not affected by this setting.

### Syntax

Exec Command									
ATQ[<n>]									
Response(s)									
If <n>=0:									
OK									
If <n>=1:									
(none)									
Reference(s)		PIN	ASC0	MUX1	MUX2	MUX3	Charge		Last
V.250		<input type="radio"/>	<input checked="" type="radio"/>	<input checked="" type="radio"/>	<input checked="" type="radio"/>	<input checked="" type="radio"/>	<input type="radio"/>	<input type="radio"/>	<input type="radio"/>

### Parameter Description

<n> <sup>(num)(&amp;W)(&amp;V)</sup>	
[0] <sup>(&amp;F)</sup>	DCE transmits result code
1	Result codes are suppressed and not transmitted

## 2.5 ATV Set result code format mode

This command determines the contents of header and trailer transmitted with AT command result codes and information responses. Possible responses are described in Section 2.5.1, [Verbose and numeric result codes](#).

### Syntax

Exec Command							
ATV[<value>]							
Response(s)							
OK							
ERROR							
Reference(s)				PIN			
V.250				ASC0			
				MUX1			
				MUX2			
				MUX3			
				Charge			
				Last			

### Parameter Description

<value><sup>(num)(&W)(&V)</sup>

- [0] Information response: <text><CR><LF>  
Short result code format: <numeric code><CR>
- 1<sup>(&F)</sup> Information response: <CR><LF><text><CR><LF>  
Long result code format: <CR><LF><verbose code><CR>

### 2.5.1 Verbose and numeric result codes

Verbose format	Numeric format	Meaning
OK	0	Command executed, no errors
CONNECT	1	Link established
RING	2	Ring detected
NO CARRIER	3	Link not established or disconnected
ERROR	4	Invalid command or command line too long
NO DIALTONE	6	No dial tone, dialling impossible, wrong mode
BUSY	7	Remote station busy
CONNECT 2400	10	Link with 2400 bps
CONNECT 4800	30	Link with 4800 bps
CONNECT 9600	32	Link with 9600 bps
CONNECT 14400	33	Link with 14400 bps
CONNECT 2400/RLP	47	Link with 2400 bps and Radio Link Protocol
CONNECT 4800/RLP	48	Link with 4800 bps and Radio Link Protocol
CONNECT 9600/RLP	49	Link with 9600 bps and Radio Link Protocol
CONNECT 14400/RLP	50	Link with 14400 bps and Radio Link Protocol
ALERTING		Alerting at called phone
DIALING		Mobile phone is dialing



## 2.6 ATX Set CONNECT result code format and call monitoring

ATX determines whether or not the TA detects the presence of dial tone and busy signal and whether or not TA transmits particular result codes.

### Syntax

Exec Command							
ATX[<value>]							
Response(s)							
OK							
ERROR							
Reference(s)				PIN			
V.250				ASC0			
				MUX1			
				MUX2			
				MUX3			
				Charge			
				Last			
				○ ● ● ● ● ○ ○ ○			

### Parameter Description

<value> <sup>(num)(&amp;W)(&amp;V)</sup>	Description
[0]	CONNECT result code only returned, dial tone and busy detection are both disabled.
1	CONNECT <text> result code only returned, dial tone and busy detection are both disabled.
2	CONNECT <text> result code returned, dial tone detection is enabled, busy detection is disabled.
3	CONNECT <text> result code returned, dial tone detection is disabled, busy detection is enabled.
4(&F)	CONNECT <text> result code returned, dial tone and busy detection are both enabled.

## 2.7 ATV Set CONNECT result code format

### Syntax

Exec Command																	
AT\V[<value>]																	
Response(s)																	
OK ERROR																	
Reference(s)	<table border="1"> <tr> <td>PIN</td> <td>ASC0</td> <td>MUX1</td> <td>MUX2</td> <td>MUX3</td> <td>Charge</td> <td></td> <td>Last</td> </tr> <tr> <td><input type="radio"/></td> <td><input checked="" type="radio"/></td> <td><input checked="" type="radio"/></td> <td><input type="radio"/></td> <td><input type="radio"/></td> <td><input type="radio"/></td> <td><input type="radio"/></td> <td><input type="radio"/></td> </tr> </table>	PIN	ASC0	MUX1	MUX2	MUX3	Charge		Last	<input type="radio"/>	<input checked="" type="radio"/>	<input checked="" type="radio"/>	<input type="radio"/>	<input type="radio"/>	<input type="radio"/>	<input type="radio"/>	<input type="radio"/>
PIN	ASC0	MUX1	MUX2	MUX3	Charge		Last										
<input type="radio"/>	<input checked="" type="radio"/>	<input checked="" type="radio"/>	<input type="radio"/>	<input type="radio"/>	<input type="radio"/>	<input type="radio"/>	<input type="radio"/>										
V.250																	

### Parameter Description

<value> <sup>(num)(&amp;W)(&amp;V)</sup>	
[0]	CONNECT <text> result code returned without RLP trailer
1(&F)	CONNECT <text> result code returned with RLP trailer

### Notes

- For circuit switched data calls only.
- Output only if [ATX](#) parameter is set with value > 0.



## 2.9 AT+CFUN Set phone functionality

The [AT+CFUN](#) command serves to control the functionality level of the ME. It can be used to reset the ME, to choose one of the SLEEP modes or to return to full functionality.

Intended for power saving, SLEEP mode reduces the functionality of the ME to a minimum and thus minimizes the current consumption. SLEEP mode falls in two categories:

- NON-CYCLIC SLEEP mode `<fun>=0`
- and CYCLIC SLEEP modes, selectable as `<fun>= 5, 6, 7 or 8`.

NON-CYCLIC SLEEP mode permanently blocks the serial interface. The CYCLIC SLEEP mode, however, is a dynamic process which alternately enables and disables the serial interface. The major benefit of all CYCLIC SLEEP modes is that the serial interface remains accessible and that, in intermittent wake-up periods, characters can be sent or received without terminating the selected mode. The best choice is using `<fun>= 7 or 8`, since in these modes TC35i automatically resumes power saving, after you have sent or received a short message or made a call. `<fun>=5 or 6` do not offer this feature to the same extent and are only supported for compatibility with earlier releases. In all CYCLIC SLEEP modes, you can enter `<fun>=1` to permanently wake up TC35i and take it back to full functionality. Please refer to Section 2.9.1, [Wake up the ME from SLEEP mode](#) for a summary of all SLEEP modes and the different ways of waking up the module.

For CYCLIC SLEEP mode (`<fun>= 5, 6, 7 or 8`) both the ME and the application must be configured to use hardware flow control. This is necessary since the CTS signal is set/reset every time when the ME listens to a paging message from the base station. This is the way how the module indicates to the application when the UART is active. For detailed information on the timing of the CTS signal refer to [2]. The default setting of hardware flow control is `AT\Q0` which must be altered to `AT\Q3`. For use after restart you are advised to add it to the user profile saved with `AT&W`.

The `AT+CFUN` test command returns the values of the supported parameters.

The `AT+CFUN` read command returns the current functionality value.

The `AT+CFUN` write command can be used to reset the ME, to choose one of the SLEEP modes or to return to full functionality.

### Syntax

<p>Test Command</p> <pre>AT+CFUN=?</pre> <p>Response(s)</p> <pre>+CFUN: (list of supported &lt;fun&gt;s) , (list of supported &lt;rst&gt;s) OK</pre>																	
<p>Read Command</p> <pre>AT+CFUN?</pre> <p>Response(s)</p> <pre>+CFUN: &lt;fun&gt; OK</pre>																	
<p>Write Command</p> <pre>AT+CFUN=[&lt;fun&gt;[, &lt;rst&gt;]]</pre> <p>Response(s)</p> <pre>OK ERROR +CME ERROR</pre>																	
<p>Reference(s)</p> <p>GSM 07.07</p>	<table border="1"> <tr> <td>PIN</td> <td>ASC0</td> <td>MUX1</td> <td>MUX2</td> <td>MUX3</td> <td>Charge</td> <td></td> <td>Last</td> </tr> <tr> <td><input type="radio"/></td> <td><input checked="" type="radio"/></td> <td><input type="radio"/></td> <td><input type="radio"/></td> <td><input type="radio"/></td> <td><input type="radio"/></td> <td><input type="radio"/></td> <td><input type="radio"/></td> </tr> </table>	PIN	ASC0	MUX1	MUX2	MUX3	Charge		Last	<input type="radio"/>	<input checked="" type="radio"/>	<input type="radio"/>	<input type="radio"/>	<input type="radio"/>	<input type="radio"/>	<input type="radio"/>	<input type="radio"/>
PIN	ASC0	MUX1	MUX2	MUX3	Charge		Last										
<input type="radio"/>	<input checked="" type="radio"/>	<input type="radio"/>	<input type="radio"/>	<input type="radio"/>	<input type="radio"/>	<input type="radio"/>	<input type="radio"/>										

## Unsolicited Result Codes

### URC 1

^SYSSTART

Indicates that the ME has been started and is ready to operate. If autobauding is active (`AT+IPR=0`) the URC is not generated.

### URC 2

^SYSSTART CHARGE ONLY MODE

Indicates that the ME has entered the CHARGE ONLY mode. This occurs if the charger is connected while the ME is in POWER DOWN mode. If autobauding is active (`AT+IPR=0`) the URC is not generated. In CHARGE ONLY mode the ME is neither registered to the GSM network nor are the serial interfaces fully accessible. Only the AT commands listed in Section 18.4, [Availability of AT Commands Depending on Operating Mode of ME](#) can be used. For further details on charging refer to the Hardware Interface Description [2].

## Parameter Description

<fun> <sup>(num)</sup>	
0	<p>NON-CYCLIC SLEEP mode: In this mode, the AT interface is not accessible. Consequently, after setting <code>&lt;fun&gt;=0</code>, do not send further characters. Otherwise these characters remain in the input buffer and may delay the output of an unsolicited result code. The first wake-up event stops power saving and takes the ME back to full functionality level <code>&lt;fun&gt;=1</code>.</p>
[1] <sup>(&amp;F)</sup>	<p>Full functionality. If the ME is in one of the CYCLIC SLEEP modes you can issue <code>AT+CFUN=1</code> to stop power saving and return to full functionality. Keep in mind that, unlike the reset command described below, this action does not restart the ME but only changes the level of functionality. See parameter <code>&lt;rst&gt;</code> for details on the reset.</p>
5	<p>CYCLIC SLEEP mode: In this mode, the serial interface is shortly enabled while CTS is active. If characters are recognized on the serial interface, the ME stays active for 2 seconds after the last character was sent or received.</p>
6	<p>CYCLIC SLEEP mode: In this mode, the serial interface is shortly enabled while CTS is active. If characters are recognized on the serial interface, the ME stays active for 10 minutes after the last character was sent or received. To ensure that power saving takes effect immediately, the ME stays active for only 2 seconds after <code>&lt;fun&gt;=6</code> was entered.</p>
7	<p>CYCLIC SLEEP mode: In this mode, the serial interface is shortly enabled while CTS is active. If characters are recognized on the serial interface, the ME stays active for 2 seconds after the last character was sent or received. ME exits SLEEP mode only, if <code>AT+CFUN=1</code> is entered.</p>
8	<p>CYCLIC SLEEP mode: In this mode, the serial interface is shortly enabled while CTS is active. If characters are recognized on the serial interface, the ME stays active for 10 minutes after the last character was sent or received. ME exits SLEEP mode only, if <code>AT+CFUN=1</code> is entered. To ensure that power saving takes effect immediately, the ME stays active for only 2 seconds after <code>&lt;fun&gt;=8</code> was entered.</p>

`<rst>(num)`

The parameter can only be used if the serial interface is enabled.

Due to the command syntax, you need to enter parameter `<fun>`, followed by `<rst>`, where `<fun>` is only a placeholder and has no effect. See examples below.

[0]	Placeholder for <code>&lt;fun&gt;</code> as stated above.
1	ME resets and restarts to full functionality. After reset and restart, PIN 1 authentication is necessary ( <code>AT+CPIN</code> ). If autobauding is enabled, it is recommended to wait 3 to 5 seconds before entering the first AT command. For details on autobauding refer to Section 4.10.1, <a href="#">Autobauding</a> .

### Notes

- In Multiplex mode, the CFUN profile is shared by all multiplexer channels.
- If the ME is in Multiplexer mode, it is not recommended to activate SLEEP mode with `AT+CFUN=<fun>`. The best approach to properly control SLEEP mode in this case is to issue the PSC messages described in [5], Section "Power saving control".
- When a circuit-switched call is in progress, `<fun>`=7 or 8 can be activated without terminating the call. However, setting `<fun>`=0, 5 or 6 during a circuit-switched call immediately disconnects this call.
- Please keep in mind that power saving works properly only when PIN authentication has been done. If you attempt to activate power saving while the SIM card is not inserted or the PIN is not correctly entered, the selected `<fun>` level will be set, though power saving does not take effect. For the same reason, power saving cannot be used if TC35i operates in Alarm mode. Furthermore, in order to accept incoming calls, SMS or network related URCs in SLEEP mode the ME must be registered when it enters the SLEEP mode.
- To check whether power saving is on, you can query the status with the read command `AT+CFUN?` only if the module is in full functionality mode or in CYCLIC SLEEP mode. If available, you can also take advantage of the status LED controlled by the SYNC pin (see `AT^SSYNC` and [2]). With `AT^SSYNC` you can select different modes of LED signalization during SLEEP modes (see Section 16.6.1, [ME status indicated by status LED patterns](#) for details). However, the module can wake up temporarily from power saving without leaving its CYCLIC SLEEP mode (without changing `+CFUN "<fun>"`), e.g. for a network scan after a loss of radio coverage, or after receipt of serial data during CYCLIC SLEEP mode. During this "temporary wakeup state" the LED will operate as if the ME was in full functionality mode.
- Recommendation: In NON-CYCLIC SLEEP mode, you can set an RTC alarm to wake up the ME and return to full functionality. This is a useful approach because, in this mode, the AT interface is not accessible.

### Examples

#### EXAMPLE 1

To check the level of functionality use the read command:

```
AT+CFUN?
+CFUN: 1                Default mode after ME was restarted
```

Remember that the AT interface is not accessible in NON-CYCLIC SLEEP mode. Consequently, the read command is only useful when the ME is set to full functionality or, when `<fun>` is set to 5, 6, 7 or 8.

```
AT+CFUN?
+CFUN: 5                CYCLIC SLEEP mode
```

#### EXAMPLE 2

To set the ME to NON-CYCLIC SLEEP mode enter

```
AT+CFUN=0
OK
```

When, for example, an SMS is being received and indicated by an unsolicited result code (URC), the ME wakes up to full operation.

```
+CMTI: "SM", 5          Note that the URC used in this example will appear only, if
                        AT+CNMI=1,1 was configured before.
```

After this, you may want to verify the operating status:

```
AT+CFUN?
+CFUN: 1
```

Indicates that ME has entered full functionality mode.

EXAMPLE 3

To stop CYCLIC SLEEP mode and return to full functionality:

```
AT+CFUN?
+CFUN: 5
OK
AT+CFUN=1
OK
```

Remember that this approach is not applicable to the NON-CYCLIC SLEEP mode (since the serial interface is disabled). The NON-CYCLIC SLEEP mode ends with the first wake-up event.

EXAMPLE 4

To reset and restart the ME:

```
AT+CFUN=1,1
OK
^SYSSTART
```

or alternatively, AT+CFUN=0,1 or 5,1 or 6,1 or 7,1 or 8,1

The ^SYSSTART URC confirms that the ME has been rebooted. Note that ^SYSSTART appears only if AT+IPR ≠ 0. If the ME is in autobaud mode, it is recommended to wait 3 to 5 seconds before entering the first AT command. Remember to enter the SIM PIN after restart.

## 2.9.1 Wake up the ME from SLEEP mode

A wake-up event is any event that causes the ME to draw more current. Depending on the selected mode, the wake-up event either switches the SLEEP mode off and takes the ME back to full functionality AT+CFUN=1, or activates the ME temporarily without terminating the selected SLEEP mode.

Definitions of the state transitions described in Table 2.3:

- Quit: ME exits SLEEP mode.
- Temporary: ME becomes active temporarily for the duration of the event and the mode-specific follow-up time after the last character was sent or received on the serial interface.
- No effect: Event is not relevant in the selected SLEEP mode. The ME does not wake up.

**Table 2.3:** Wake-up events in NON-CYCLIC and CYCLIC SLEEP modes

Event	Selected mode: <fun>=0	Selected mode: <fun>=5 or 6	Selected mode: <fun>=7 or 8
Ignition line	No effect	No effect	No effect
/RTS0	Quit	No effect (RTS is only used for flow control)	No effect (RTS is only used for flow control)
Unsolicited Result Code (URC)	Quit	Quit	Temporary
Incoming voice or data call	Quit	Quit	Temporary
Any AT command (incl. outgoing SMS, voice or data call)	Not possible (UART disabled)	Temporary	Temporary
Incoming SMS (AT+CNMI is set to 0,0 (this is the default setting))	No effect	No effect	No effect
Incoming SMS (AT+CNMI is set to 1,1)	Quit	Quit	Temporary

---



Event	Selected mode: <fun>=0	Selected mode: <fun>=5 or 6	Selected mode: <fun>=7 or 8
RTC alarm line	Quit	Quit	Temporary
AT+CFUN=1	Not possible (UART disabled)	Quit	Quit



## 2.10 AT^SMSO Switch off mobile station

[AT^SMSO](#) initiates the power-off procedure. Low level of the module's VDD pin and the URC "[^SHUTDOWN](#)" notify that the procedure has completed and the module has entered the POWER DOWN mode. Therefore, be sure not to disconnect the operating voltage until VDD is low or until the URC "[^SHUTDOWN](#)" is displayed. Otherwise, you run the risk of losing data. For further details on how to turn off the module see the [\[2\]](#).

### Syntax

Test Command	AT^SMSO=?																
Response(s)	OK																
Exec Command	AT^SMSO																
Response(s)	^SMSO: MS OFF OK																
Reference(s)	--																
	<table border="1"><tr><td>PIN</td><td>ASC0</td><td>MUX1</td><td>MUX2</td><td>MUX3</td><td>Charge</td><td></td><td>Last</td></tr><tr><td><input type="radio"/></td><td><input checked="" type="radio"/></td><td><input checked="" type="radio"/></td><td><input checked="" type="radio"/></td><td><input checked="" type="radio"/></td><td><input checked="" type="radio"/></td><td><input checked="" type="radio"/></td><td><input checked="" type="radio"/></td></tr></table>	PIN	ASC0	MUX1	MUX2	MUX3	Charge		Last	<input type="radio"/>	<input checked="" type="radio"/>	<input checked="" type="radio"/>	<input checked="" type="radio"/>	<input checked="" type="radio"/>	<input checked="" type="radio"/>	<input checked="" type="radio"/>	<input checked="" type="radio"/>
PIN	ASC0	MUX1	MUX2	MUX3	Charge		Last										
<input type="radio"/>	<input checked="" type="radio"/>	<input checked="" type="radio"/>	<input checked="" type="radio"/>	<input checked="" type="radio"/>	<input checked="" type="radio"/>	<input checked="" type="radio"/>	<input checked="" type="radio"/>										

### Unsolicited Result Code

[^SHUTDOWN](#)

Indicates that the power-off procedure is finished and the module will be switched off in less than 1 second.

### Notes

- Do not send any other AT command after [AT^SMSO](#).
- If [AT^SMSO](#) is entered on one of the Multiplexer channels the ME closes the Multiplexer channels, terminates the Multiplexer and deactivates all other functions. Then, the URC "[^SHUTDOWN](#)" will be issued on the physical serial interface (ASC0). The URC will be transmitted at the bit rate last activated on ASC0 for use with the Multiplex driver.

## 2.11 AT+GCAP Request complete TA capabilities list

AT+GCAP returns a list of additional capabilities.

### Syntax

Test Command	
AT+GCAP=?	
Response(s)	
OK	
Exec Command	
AT+GCAP	
Response(s)	
+GCAP: <name>	
OK	
Reference(s)	
V.250	
	PIN ASC0 MUX1 MUX2 MUX3 Charge  Last
	<input type="radio"/> <input checked="" type="radio"/> <input checked="" type="radio"/> <input checked="" type="radio"/> <input checked="" type="radio"/> <input type="radio"/> <input type="radio"/> <input type="radio"/>

### Parameter Description

<name> <sup>(str)</sup>
e.g.: +CGSM,+FCLASS

### Note

- +CGSM: The response text shows which GSM commands of the ETSI standard are supported.

## 2.12 AT+CMEE Mobile Equipment Error Message Format

AT+CMEE controls the format of the error result codes that indicates errors related to TC35i functionality. Format can be selected between plain "ERROR" output, error numbers or verbose "+CME ERROR: <err>" and "+CMS ERROR: <err>" messages.

Possible error result codes are listed in Table 2.4, [General "CME ERROR" Codes \(GSM 07.07\)](#) and Table 2.5, [SMS related "CMS ERROR" Codes \(GSM 07.05\)](#).

In multiplex mode (refer AT+CMUX) the setting applies only to the logical channel where selected. The setting on the other channels may differ.

### Syntax

<p>Test Command</p> <p>AT+CMEE=?</p> <p>Response(s)</p> <p>+CMEE: (list of supported&lt;errMode&gt;s)</p> <p>OK</p>																	
<p>Read Command</p> <p>AT+CMEE?</p> <p>Response(s)</p> <p>+CMEE: &lt;errMode&gt;</p> <p>OK</p>																	
<p>Write Command</p> <p>AT+CMEE=&lt;errMode&gt;</p> <p>Response(s)</p> <p>OK</p> <p>ERROR</p> <p>+CME ERROR: &lt;err&gt;</p>																	
<p>Reference(s)</p> <p>GSM 07.07</p>	<table border="1"> <tr> <td>PIN</td> <td>ASC0</td> <td>MUX1</td> <td>MUX2</td> <td>MUX3</td> <td>Charge</td> <td></td> <td>Last</td> </tr> <tr> <td><input type="radio"/></td> <td><input checked="" type="radio"/></td> <td><input checked="" type="radio"/></td> <td><input checked="" type="radio"/></td> <td><input checked="" type="radio"/></td> <td><input type="radio"/></td> <td><input type="radio"/></td> <td><input type="radio"/></td> </tr> </table>	PIN	ASC0	MUX1	MUX2	MUX3	Charge		Last	<input type="radio"/>	<input checked="" type="radio"/>	<input checked="" type="radio"/>	<input checked="" type="radio"/>	<input checked="" type="radio"/>	<input type="radio"/>	<input type="radio"/>	<input type="radio"/>
PIN	ASC0	MUX1	MUX2	MUX3	Charge		Last										
<input type="radio"/>	<input checked="" type="radio"/>	<input checked="" type="radio"/>	<input checked="" type="radio"/>	<input checked="" type="radio"/>	<input type="radio"/>	<input type="radio"/>	<input type="radio"/>										

### Parameter Description

<errMode> <sup>(num)(&amp;W)(&amp;V)</sup>	
0 <sup>(&amp;F)(D)</sup>	Disable result code, i.e. only "ERROR" will be displayed.
1	Enable error result code with numeric values.
2	Enable error result code with verbose (string) values.

### Example

To obtain enhanced error messages it is recommended to choose <errMode>=2.

```
AT+CMEE=2
OK
```

## 2.12.1 CME/CMS Error Code Overview

**Table 2.4:** General "CME ERROR" Codes (GSM 07.07)

<err> Code	Text (if AT+CMEE=2)
0	phone failure
1	no connection to phone
2	phone-adaptor link reserved
3	Operation not allowed
4	Operation not supported
5	PH-SIM PIN required
6	PH-FSIM PIN required
7	PH-FSIM PUK required
10	SIM not inserted
11	SIM PIN required
12	SIM PUK required
13	SIM failure
14	SIM busy
15	SIM wrong
16	Incorrect password
17	SIM PIN2 required
18	SIM PUK2 required
20	Memory full
21	invalid index
22	not found
23	Memory failure
24	text string too long
25	invalid characters in text string
26	dial string too long
27	invalid characters in dial string
30	no network service
31	Network timeout
32	Network not allowed emergency calls only
40	Network personalization PIN required
41	Network personalization PUK required
42	Network subset personalization PIN required
43	Network subset personalization PUK required
44	service provider personalization PIN required
45	service provider personalization PUK required
46	Corporate personalization PIN required
47	Corporate personalization PUK required
48	Master Phone Code required
100	unknown
132	service option not supported

<err> Code	Text (if AT+CMEE=2)
133	requested service option not subscribed
134	service option temporarily out of order
256	Operation temporary not allowed
257	call barred
258	phone is busy
259	user abort
260	invalid dial string
261	ss not executed
262	SIM blocked
263	Invalid Block

**Table 2.5:** SMS related "CMS ERROR" Codes (GSM 07.05)

<err> Code	Text (if AT+CMEE=2)
1	Unassigned (unallocated) number
8	Operator determined barring
10	Call barred
21	Short message transfer rejected
27	Destination out of service
28	Unidentified subscriber
29	Facility rejected
30	Unknown subscriber
38	Network out of order
41	Temporary failure
42	Congestion
47	Resources unavailable, unspecified
50	Requested facility not subscribed
69	Requested facility not implemented
81	Invalid short message transfer reference value
95	Invalid message, unspecified
96	Invalid mandatory information
97	Message type non-existent or not implemented
98	Message not compatible with short message protocol state
99	Information element non-existent or not implemented
111	Protocol error, unspecified
127	Interworking, unspecified
128	Telematic interworking not supported
129	Short message Type 0 not supported
130	Cannot replace short message
143	Unspecified TP-PID error
144	Data coding scheme (alphabet) not supported
145	Message class not supported
159	Unspecified TP-DCS error

<err> Code	Text (if AT+CMEE=2)
160	Command cannot be actioned
161	Command unsupported
175	Unspecified TP-Command error
176	TPDU not supported
192	SC busy
193	No SC subscription
194	SC system failure
195	Invalid SME address
196	Destination SME barred
197	SM Rejected-Duplicate SM
198	TP-VPF not supported
199	TP-VP not supported
208	D0 SIM SMS storage full
209	No SMS storage capability in SIM
210	Error in MS
211	Memory Capacity Exceeded
212	SIM Application Toolkit Busy
213	SIM data download error
255	Unspecified error cause
300	ME failure
301	SMS service of ME reserved
302	Operation not allowed
303	Operation not supported
304	Invalid PDU mode parameter
305	Invalid text mode parameter
310	SIM not inserted
311	SIM PIN required
312	PH-SIM PIN required
313	SIM failure
314	SIM busy
315	SIM wrong
316	SIM PUK required
317	SIM PIN2 required
318	SIM PUK2 required
320	Memory failure
321	Invalid memory index
322	Memory full
330	SMSC address unknown
331	no network service
332	Network timeout
340	NO +CNMA ACK EXPECTED
500	Unknown error

---

<err> Code	Text (if AT+CMEE=2)
512	User abort
513	unable to store
514	invalid status
515	invalid character in address string
516	invalid length
517	invalid character in pdu
518	invalid parameter
519	invalid length or character
520	invalid character in text
521	timer expired
522	Operation temporary not allowed

## 2.13 AT+CSCS Select TE character set

The [AT+CSCS](#) write command informs the TA which character set `<chset>` is used by the TE. This enables the TA to convert character strings correctly between TE and ME character sets. See also Section 1.5, [Supported character sets](#).

Note that when the TA-TE interface is set to 8-bit operation and the used TE alphabet is 7-bit, the highest bit will be set to zero.

### Syntax

<p>Test Command</p> <pre>AT+CSCS=?</pre> <p>Response(s)</p> <pre>+CSCS: (list of supported&lt;chset&gt;s) OK</pre>																	
<p>Read Command</p> <pre>AT+CSCS?</pre> <p>Response(s)</p> <pre>+CSCS: &lt;chset&gt; OK</pre>																	
<p>Write Command</p> <pre>AT+CSCS=[&lt;chset&gt;]</pre> <p>Response(s)</p> <pre>OK</pre>																	
<p>Reference(s)</p> <pre>GSM 07.07, GSM 11.11</pre>	<table border="1"> <tr> <td>PIN</td> <td>ASC0</td> <td>MUX1</td> <td>MUX2</td> <td>MUX3</td> <td>Charge</td> <td></td> <td>Last</td> </tr> <tr> <td><input type="radio"/></td> <td><input checked="" type="radio"/></td> <td><input checked="" type="radio"/></td> <td><input checked="" type="radio"/></td> <td><input checked="" type="radio"/></td> <td><input type="radio"/></td> <td><input type="radio"/></td> <td><input type="radio"/></td> </tr> </table>	PIN	ASC0	MUX1	MUX2	MUX3	Charge		Last	<input type="radio"/>	<input checked="" type="radio"/>	<input checked="" type="radio"/>	<input checked="" type="radio"/>	<input checked="" type="radio"/>	<input type="radio"/>	<input type="radio"/>	<input type="radio"/>
PIN	ASC0	MUX1	MUX2	MUX3	Charge		Last										
<input type="radio"/>	<input checked="" type="radio"/>	<input checked="" type="radio"/>	<input checked="" type="radio"/>	<input checked="" type="radio"/>	<input type="radio"/>	<input type="radio"/>	<input type="radio"/>										

### Parameter Description

<code>&lt;chset&gt;</code> <sup>(str)</sup>	
"GSM" <sup>(&amp;F)</sup>	GSM default alphabet (GSM 03.38 subclause 6.2.1); Note: This setting may cause software flow control problems since the codes used to stop and resume data flow (XOFF = decimal 19, XON = decimal 17) are interpreted as normal characters.
"UCS2"	16-bit universal multiple-octet coded character set (ISO/IEC10646 [32]); UCS2 character strings are converted to hexadecimal numbers from 0000 to FFFF; e.g. "004100620063" equals three 16-bit characters with decimal values 65, 98 and 99.



## 2.14 AT^SCFG Extended Configuration Settings

AT^SCFG can be used to query and configure various settings of the TC35i.

The AT^SCFG read command returns a list of all supported parameters and their current values.

The AT^SCFG write command queries a configuration parameter (if no value is entered) or sets its value(s).

Input of parameter names is always coded in GSM character set, parameter values are expected to be given as specified via AT+CSCS.

The following error messages may be returned by the AT^SCFG write commands:

- "+CME ERROR: operation temporary not allowed"  
Change of parameter value(s) temporarily not allowed.
- "+CME ERROR: invalid index"  
Invalid parameter name or value(s).
- "+CME ERROR: invalid characters in text string"  
Character set conversion of parameter value(s) failed.
- "+CME ERROR: memory failure"  
Could not allocate necessary memory or storing a parameter failed.
- "+CME ERROR: operation not allowed"  
Change of parameter value(s) not allowed
- "+CME ERROR: unknown"  
Other error

### Syntax

Test Command

AT^SCFG=?

Response(s)

```
^SCFG: "AutoExec", (list of supported <AutoExecCmd>), (list of supported <AutoExecType>), (list of supported <AutoExecIndex>), (list of supported <AutoExecMode>), (max. string length of <AutoExecATC>), (time range of <AutoExecPeriod>)
^SCFG: "Call/ATS0/CSV", (list of supported <cs0csv>s)
^SCFG: "Call/SpeechVersion1", (list of supported <csv1>s)
^SCFG: "CSD/SendLLC", (list of supported <CsdLlc>s)
^SCFG: "Radio/Band", (list of supported <rba>s)
OK
```

Read Command

AT^SCFG?

Response(s)

```
^SCFG: "AutoExec", <AutoExecCmd>, <AutoExecType>, <AutoExecIndex>, <AutoExecMode>, <AutoExecATC>[, <AutoExecPeriod>, <AutoExecPeriodTimeLeft>]
^SCFG: "Call/ATS0/CSV", (list of supported <cs0csv>s)
^SCFG: "Call/SpeechVersion1", <csv1>
^SCFG: "CSD/SendLLC", <CsdLlc>
^SCFG: "Radio/Band", <rba>
OK
```

Write Command

Automatic AT command execution

```
AT^SCFG="AutoExec", <AutoExecCmd>, <AutoExecType>, <AutoExecIndex>[, <AutoExecMode>, <AutoExecATC>[, <AutoExecPeriod>]]
```

Response(s)

```
^SCFG: "AutoExec", <AutoExecCmd>, <AutoExecType>, <AutoExecIndex>, <AutoExecMode>, <AutoExecATC>[, <AutoExecPeriod>, <AutoExecPeriodTimeLeft>]
OK
```

Write Command

(Continued)

Automatic AT command execution

```
AT^SCFG="AutoExec", <AutoExecCmd>, <AutoExecType>, <AutoExecIndex>[, <AutoExecMode>, <AutoExecATC>[, <AutoExecPeriod>]]
```

Response(s)

```
ERROR  
+CME ERROR
```

Write Command

Query/Configure ATSO for CS voice calls

```
AT^SCFG="Call/ATSO/CSV"[, <cs0csv>]
```

Response(s)

```
^SCFG: "Call/ATSO/CSV", <cs0csv>  
OK  
ERROR  
+CME ERROR
```

Write Command

Query/Configure SpeechVersion1

```
AT^SCFG="Call/SpeechVersion1"[, <csv1>]
```

Response(s)

```
^SCFG: "Call/SpeechVersion1", <csv1>  
OK  
ERROR  
+CME ERROR
```

Write Command

Disable/enable sending of optional LLC-IE (Low Layer Compatibility) for mobile originated ISDN data calls:

```
AT^SCFG="CSD/SendLLC"[, <CsdLlc>]
```

Response(s)

```
^SCFG: "CSD/SendLLC", <CsdLlc>  
OK  
ERROR  
+CME ERROR
```

Write Command

Radio band selection

```
AT^SCFG="Radio/Band"[, <rba>]
```

Response(s)

```
^SCFG: "Radio/Band", <rba>  
OK  
ERROR  
+CME ERROR
```

PIN ASC0 MUX1 MUX2 MUX3 Charge  Last

**Unsolicited Result Code**

```
^SCFG: "AutoExec", <AutoExecState>, <AutoExecType>, <AutoExecIndex>, <AutoExecMode>, <AutoExecATC>
```

If the event specified with <AutoExecType> occurs and the related AT command line is executed this URC is issued.

### Parameter Description

**<AutoExecCmd>**<sup>(str)(+CSCS)</sup>

#### AutoExec Command

This parameter serves to switch the Autoexec function on or off.

If it is switched off (<AutoExecCmd>=0), parameters following <AutoExecIndex> are ignored and all settings at the given index are restored to their default values.

Value will be saved while switching off the TC35i via AT commands (e.g. AT+CFUN or AT^SMSO) and restored on next power up.

- "0" Disable automatic execution of the AT command(s) specified with <AutoExecATC> at a given <AutoExecIndex>.
- "1" Enable automatic execution of the AT command(s) specified with <AutoExecATC> at a given <AutoExecIndex>. Not allowed for <AutoExecType>=0 (DTR line activation) while multiplex mode is active, refer to AT+CMUX.

**<AutoExecType>**<sup>(str)(+CSCS)</sup>

#### AutoExec Event Type

This parameter selects the kind of event used to automatically launch the AT command(s) specified with <AutoExecATC>.

Value will be saved while switching off the TC35i via AT commands (e.g. AT+CFUN or AT^SMSO) and restored on next power up.

- "0" Autoexec activity is driven by ASC0 DTR line activation (OFF-ON transition).
- "1" Autoexec activity is timer driven. To specify the time span use <AutoExecPeriod>.

**<AutoExecIndex>**<sup>(str)(+CSCS)</sup>

#### AutoExec Command Index

This parameter specifies the command storage index. The following table shows the index ranges supported for each variant of <AutoExecType>.

Value will be saved while switching off the TC35i via AT commands (e.g. AT+CFUN or AT^SMSO) and restored on next power up.

<AutoExecType> value	<AutoExecType> event	Valid Indices
0	Autoexec activity is driven by ASC0 DTR line activation	0
1	Autoexec activity is timer driven.	0-2

**<AutoExecMode>**<sup>(str)(+CSCS)</sup>

#### AutoExec Command Mode

0...255

This parameter specifies details regarding the behavior of the TC35i when the AT command starts to be executed.

Value is interpreted as a bit field, unused bits are reserved for future use (RFU) and shall be set to 0.

When a call is released by an Autoexec activity, no release indication may be issued on the first logical channel. If during a data call the TC35i temporarily enters command mode via +++ no AT command will be executed if <AutoExecMode> specifies 'Ignore ongoing calls'.

Value will be saved while switching off the TC35i via AT commands (e.g. AT+CFUN or AT^SMSO) and restored on next power up.

Bit	Mask <sub>hex</sub>	Mask <sub>dec</sub>	Control
D <sub>0</sub>	0x00	0	00: Ignore ongoing calls
D <sub>1</sub>	0x01	1	01: Wait until all calls have ended
	0x02	2	10: Dismiss any ongoing call
	0x03	3	11: RFU
D <sub>2</sub>	0x04	4	0: One shot action
			1: Periodic action (for "AutoExec/Period" only)
D <sub>3</sub>	0x08	8	RFU
D <sub>4</sub>	0x10	16	RFU
D <sub>5</sub>	0x20	32	RFU
D <sub>6</sub>	0x40	64	RFU
D <sub>7</sub>	0x80	128	RFU

<AutoExecATC><sup>(str)(+CSCS)</sup>

#### AutoExec AT command String

This parameter specifies the AT command(s) to be launched automatically. Each AT command is executed in the same way as if it were entered online, this means that command concatenation is possible if supported by the given commands. If serial multiplex mode is activated ([AT+CMUX](#)) the first logical channel is used, i.e. CSD calls (data or fax) could be set up. If the TC35i is busy on the serial channel command execution will be delayed until ongoing action is finished.

The first two characters of the automatically launched AT command shall be "at" and its length shall be less than 25 characters.

Please refer to examples below.

Value will be saved while switching off the TC35i via AT commands (e.g. [AT+CFUN](#) or [AT^SMSO](#)) and restored on next power up.

<AutoExecPeriod><sup>(str)(+CSCS)</sup>

#### AutoExec Command Period

Parameter specifies the period after which [<AutoExecATC>](#) will be executed. Format is "hhh:mm:ss", where characters indicate hours, minutes and seconds. This parameter applies to [<AutoExecType>=1](#) only.

Value will be saved while switching off the TC35i via AT commands (e.g. [AT+CFUN](#) or [AT^SMSO](#)) and restored on next power up.

000:00:05...240:00:00

<AutoExecPeriodTimeLeft><sup>(str)(+CSCS)</sup>

#### AutoExec Command Period Left

This parameter shows the amount of time left until [<AutoExecATC>](#) will be executed. Format is "hhh:mm:ss", where characters indicate hours, minutes and seconds. This parameter applies to [<AutoExecType>=1](#) only. Due to the internal activity and network signaling an execution delay of several seconds may occur for the overall procedure.

000:00:00...240:00:00

<AutoExecState><sup>(str)(+CSCS)</sup>

#### AutoExec Command Status

This parameter is part of the Autoexec URC which is presented when a scheduled Autoexec activity is being performed.

"1"

The value 1 indicates that the Autoexec activity specified with [<AutoExec-ATC>](#) is currently executed.

<CsdLLC><sup>(str)(+CSCS)</sup>

#### CSD Send LLC

Parameter allows to disable or enable sending of optional LLC-IE (Low Layer Compatibility) for mobile originated ISDN data calls.

Parameter is global for all interfaces, volatile and will not be reset by [AT&F](#).

“0”<sup>(P)</sup>                                      Disable sending of LLC.  
“1”    Enable sending of LLC.

<CSv1><sup>(str)(+CSCS)</sup>

#### Call Speech Version1

This parameter can be used to query or configure the speech version 1 indication in the bearer capabilities in case of voice calls (see GSM 04.08). Speech version 2 (EFR) is always enabled; speech version 3 (AMR) is not affected by this command.

If you try to change this parameter as long as a circuit switched call is active, command will return with "+CME ERROR: operation temporary not allowed".

Parameter is global for the ME, volatile and will not be reset by [AT&F](#).

“0”<sup>(P)</sup>                                      FR and HR codecs are enabled for speech calls - full rate codec is preferred.  
“1”    FR and HR codecs are enabled for speech calls - half rate codec is preferred.  
“2”    Half rate codec is disabled for speech calls.

<CS0CSv><sup>(str)(+CSCS)</sup>

#### ATS0 handling for CS voice calls

Parameter allows to disable or enable [ATS0](#) handling for CS voice calls.

Parameter is local for the interface, volatile and will not be reset by [AT&F](#).

“disabled”                                [ATS0](#) is not applied for CS voice calls  
“enabled”<sup>(P)</sup>                                [ATS0](#) will be applied for CS voice calls too

<rba><sup>(str)(+CSCS)</sup>

#### Allowed radio band(s)

This parameter specifies the frequency band(s) the ME is allowed to use.

The status of the SIM PIN authentication remains unchanged, eliminating the need to enter the SIM PIN again after the change.

The value may be one of the single bands listed below or the combination of both. Thus, the value range of [<rba>](#) is "1".."3". To select or deselect a band calculate the sum of the values of all desired bands and enter the resulting value. For example, for 900 MHz (1) and 1800 MHz (2) please enter the value (3).

Parameter [<rba>](#) is global for the ME, non-volatile and will not be reset by [AT&F](#). But changes of [<rba>](#) will be stored only, if SIM is inserted, PIN1 is already entered and SIM allows it (see Common PCN Handset Specification (CPHS) v4.2, Customer Service Profile, Multiple Band).

“1”    GSM 900 MHz  
“2”    GSM 1800 MHz  
“3”    GSM 900 MHz + GSM 1800 MHz

#### Notes

- Any changes to parameters of the Autoexec function will be saved and restored on next power-up only when the ME is switched off via AT commands (e.g. [AT+CFUN](#) or [AT^SMSO](#)).

- If parameter `<AutoExecType>=0`, the `AT^SCFG` command offers more options than the `AT%D` command you may also use to configure an automatic procedure driven by the DTR signal. The major difference is that `AT%D` is intended only to automatically set up a call. Furthermore note that there is a difference in handling an ongoing event when DTR is toggled again: The DTR signal cannot be toggled when a call initiated due to settings made with `AT%D` is still ongoing. However, when there is a call initiated due to DTR settings made with `<AutoExecType>=0`, DTR toggling is accepted, disconnects the ongoing call and dials the same call again. Avoid to configure DTR driven events via `AT%D` and `<AutoExecType>=0` at the same time. Otherwise, if both settings are enabled at a time, only the action specified with `AT%D` will be performed.
- Please keep in mind, that each time the ME is restarted the timers of all autoexec actions configured with `<AutoExecType>=1` and `<AutoExecPeriod>` will be reinitialized and restarted. As a result, an autoexec action configured at a time later than a scheduled automatic restart would never be executed.
- Be careful using `<AutoExecType>=1` with small period values and shutdown or reset AT commands, since only little time remains to change these settings again after TC35i restart.
- If `<AutoExecATC>` uses AT commands containing secret data, this information may be retrieved with `AT^SCFG?`. For instance, this applies if using `AT+CPIN`.
- Parameter "CSD/SendLLC" is not available for TC35i Release 1 modules!

## Examples

### EXAMPLE 1

Enable sending of a short message (SMS) on next DTR activation (OFF-ON transition). Sent SMS is assumed to be stored at first location of storage selected with `AT+CPMS` and `AT^SSMSS`, i.e. SMS may be sent either from SIM or ME storage.

Also refer to `AT+CMSS` and `AT+CMGW`. Since SMS transmission and ongoing calls are possible at the same time there is no need to wait until all calls have ended (`<AutoExecMode>=0`).

```

AT+CMGF=1           Enable SMS text mode.
OK
AT+CNMI=1,1        Enable "+CMTI:" URC to be indicated when a short
                    message is received.

OK
AT+CMGD=1          Delete first SMS location.
OK
AT+CMGW="01522400045",145  Start writing a short message.
>Test-SMS to be sent from storage!  Enter the text of the message. Finish with CTRL-Z.
+CMGW: 1           Confirms that message is stored to first location.
OK
AT^SCFG="AutoExec",1,0,0,0,"AT+CMSS=1"  Enable execution on next DTR activation.
^SCFG: "AutoExec","1","0","0","0","0","at+cmss=1"
^SCFG: "AutoExec","0","1","0","0","0","0","000:00:00","000:00:00"
^SCFG: "AutoExec","0","1","1","0","0","0","000:00:00","000:00:00"
^SCFG: "AutoExec","0","1","2","0","0","0","000:00:00","000:00:00"
OK

```

If a DTR activation has occurred the ME issues the URC `^SCFG: "` followed by the response of the executed command; the message reference in this case:

```

^SCFG: "AutoExec",0,0,1,0,"AT+CMSS=1"
OK           Confirms that AT+CMSS=1 has been issued.
+CMSS: 16

```

### EXAMPLE 2

Configure TC35i to perform a reset every 10 hours. The execution of the reset command shall be deferred until after any calls have ended.

For details regarding software controlled power down refer to `AT+CFUN` and `AT^SMSO`.

```

AT^SCFG="AutoExec",1,1,2,5,"AT+CFUN=0,1","010:00:00"
...
OK

```

After ten hours:

```
^SCFG: "AutoExec", 1, 1, 2, 5, "AT+CFUN=0, 1"  
OK  
SYSSTART
```

Confirms that AT+CFUN=0,1 has been issued. TC35i has restarted. Remember that the "SYSSTART" URC will not appear if autobauding is enabled.

EXAMPLE 3

Switch off the ME after three minutes without restarting it.  
For details regarding software controlled power down refer to [AT+CFUN](#) and [AT^SMSO](#).

```
AT^SCFG= "AutoExec", 1, 1, 2, 0, "AT^SMSO", "000:03:00"  
...  
OK
```

After three minutes:

```
^SCFG: "AutoExec", 0, 1, 2, 0, "AT^SMSO"  
^SMSO: MS OFF  
^SHUTDOWN
```

Indicates that AT^SMSO was successfully executed. The ME enters the POWER DOWN mode.

EXAMPLE 4

Deactivate a timer-driven Autoexec function configured at [<AutoExecIndex>](#) 2 (such as the periodic automatic reset or the automatic switch-off functions configured in the preceding examples):

```
AT^SCFG= "AutoExec", 0, 1, 2  
...  
OK
```

## 2.15 AT^SM20 Set M20 compatibility mode

M20 is an earlier, widely used GSM engine. The [AT^SM20](#) command selects different modes of responses returned upon execution of the commands [ATD](#) and sms commands like e.g. [AT+CMGW](#). Please note that the [AT^SM20](#) command has no effect on any other features and is not intended to adjust other differences between M20 and TC35i.

### Syntax

<p>Test Command</p> <p>AT^SM20=?</p> <p>Response(s)</p> <p>OK</p>	
<p>Read Command</p> <p>AT^SM20?</p> <p>Response(s)</p> <p>^SM20: &lt;CallMode&gt;, &lt;CmgwMode&gt;</p> <p>OK</p>	
<p>Write Command</p> <p>AT^SM20=&lt;CallMode&gt;[, &lt;CmgwMode&gt;]</p> <p>Response(s)</p> <p>OK</p>	
<p>Reference(s)</p> <p>--</p>	<p>PIN    ASC0    MUX1    MUX2    MUX3    Charge        Last</p> <p><input type="radio"/>    <input checked="" type="radio"/>    <input checked="" type="radio"/>    <input checked="" type="radio"/>    <input checked="" type="radio"/>    <input type="radio"/>    <input type="radio"/>    <input type="radio"/></p>

### Parameter Description

<b>&lt;CallMode&gt;<sup>(num)</sup></b>	
Call setup response mode Applies only to voice calls.	
0	Set compatibility to Cinterion Wireless Modules. ME will return "OK" immediately after attempting a call with the <a href="#">ATD</a> command. In case of failure, additional call release indications, such as "NO DIAL TONE", "NO CARRIER", "BUSY" will follow.
1(&F)	Default call setup mode, compatible to M20. ME will return "OK" in case of a successful connection, otherwise one of the call release indications "NO DIAL TONE", "NO CARRIER", "BUSY" are indicated.
<b>&lt;CmgwMode&gt;<sup>(num)</sup></b>	
Response mode for sending and writing short messages Applies to the sms commands like e.g. <a href="#">AT+CMGS</a> and <a href="#">AT+CMGW</a> command.	
0	Set compatibility to Cinterion Wireless Modules. ME will return +C MS ERROR: <err> when writing or sending of short messages fails.
1(&F)	Default mode for sending and writing short messages, compatible to M20. ME will return "OK", no matter whether or not sms command was successfully executed.



### 3. Status Control Commands

The AT Commands described in this chapter allow the external application to obtain various status information from the TC35i.

#### 3.1 AT+CMER Mobile Equipment Event Reporting

This command controls details of the "+CIEV" URC presentation related to AT^SIND and AT+CIND. If registered via these commands the URCs are sent whenever a value of the related indicator changes.

The read command returns the URC presentation mode <mode> and among others, the indicator event reporting status <ind>.

The write comm and enables and disables the presentation of "+CIEV: <indDescr>, <indValue>" URCs. <indDescr> refers to the name of a "+CIEV" indicator and <indValue> is the new value of this indicator. After AT+CMER has been switched on, URCs for all registered indicators will be issued. See examples provided in Section 3.2, AT+CIND and Section 3.3, AT^SIND.

#### Syntax

Test Command AT+CMER=? Response(s) +CMER: (list of supported <mode>s), (list of supported <keyp>s), (list of supported <disp>s), (list of supported <ind>s), (list of supported <bfr>s) OK																	
Read Command AT+CMER? Response(s) +CMER: <mode>, <keyp>, <disp>, <ind>, <bfr> OK																	
Write Command AT+CMER=[<mode>[, <keyp>[, <disp>[, <ind>[, <bfr>]]]]] Response(s) OK ERROR +CME ERROR																	
Reference(s) GSM 07.07	<table border="1"> <tr> <td>PIN</td> <td>ASC0</td> <td>MUX1</td> <td>MUX2</td> <td>MUX3</td> <td>Charge</td> <td></td> <td>Last</td> </tr> <tr> <td>●</td> <td>●</td> <td>●</td> <td>●</td> <td>●</td> <td>○</td> <td>○</td> <td>○</td> </tr> </table>	PIN	ASC0	MUX1	MUX2	MUX3	Charge		Last	●	●	●	●	●	○	○	○
PIN	ASC0	MUX1	MUX2	MUX3	Charge		Last										
●	●	●	●	●	○	○	○										

#### Unsolicited Result Code

+CIEV: <indDescr>, <indValue>

A value of an indicator has changed.

### Parameter Description

<b>&lt;mode&gt;</b> <sup>(num)&amp;W</sup>	
0(&F)	Discard "+CIEV" URCs.
1	Discard "+CIEV" URCs when TA-TE link is reserved, e.g. in online data mode. Otherwise they are forwarded directly to the TE.
2	Buffer "+CIEV" URCs in the TA while TA-TE link is reserved, e.g. in online data mode, and flush them to the TE afterwards. Otherwise they are forwarded directly to the TE.
3	Forward "+CIEV" URCs directly to the TE. If TC35i is in online data mode, URCs are signaled via sending BREAK (100ms) and stored in a buffer. Once it is back in command mode e.g. after +++ was entered, all URCs stored in the buffer will be output.
<b>&lt;keyp&gt;</b> <sup>(num)</sup>	
0(&F)	Keypad event reporting is not supported by TC35i.
<b>&lt;disp&gt;</b> <sup>(num)</sup>	
0(&F)	Display event reporting is not supported by TC35i.
<b>&lt;ind&gt;</b> <sup>(num)&amp;W</sup>	
0(&F)	Disable indicator event reporting.
2	Enable indicator event reporting.
<b>&lt;bfr&gt;</b> <sup>(num)</sup>	
0(&F)	TA buffer of URCs defined within this command is cleared when <mode> 1..3 is entered.
<b>&lt;indDescr&gt;</b> <sup>(str)</sup>	
Name of indicator; for a list of all supported indicators please refer to <a href="#">AT+CIND</a> and <a href="#">AT^SIND</a> .	
<b>&lt;indValue&gt;</b> <sup>(num)</sup>	
Value of indicator; for a list of all values for the supported indicators please refer to <a href="#">AT+CIND</a> and <a href="#">AT^SIND</a> .	

### Note

- If the ME operates on different instances (MUX channels 1, 2, 3) avoid different settings for routing and indicating SMS. For example, if messages shall be routed directly to one instance of the TE (set with [AT+CNMI](#), [AT^SSDA](#)), it is not possible to activate the presentation of URCs with [AT+CMER](#) or [AT+CNMI](#) on another instance. Any attempt to activate settings that conflict with existing settings on another interface, will result in CME ERROR, or accordingly CMS ERROR.

## 3.2 AT+CIND Indicator control

The **AT+CIND** command controls the presentation of Indicator Event Reports related to various functions such as battery charge level, signal quality, service availability, sound generation, indication of unread short messages, full SMS storage, call in progress or roaming activities.

Use of **AT+CIND** has become outdated. Rather we recommend the more powerful **AT^SIND** command which is easier to use and provides additional indicators. All indicators provided by **AT+CIND** can be handled with **AT^SIND** as well.

**AT+CIND** supports two ways to get the values related to indicators:

- One approach is to query the current status of each indicator by using the read command **AT+CIND?**. It returns the status no matter whether the indicator has been registered with the write command **AT+CIND=[<mode>[,<mode>[,...]]]**.
- The other way is an event-driven notification based on the "+CIEV" URCs. In this case, the ME will automatically send a message to the application, whenever the value of an indicator changes. The application should be designed to react adequately when receiving a URC. The presentation of these URCs depends on two settings:
  - The indicators must be registered with the write command **AT+CIND=[<mode>[,<mode>[,...]]]**. When the ME is switched on all of them are in registered mode. Any indicator can be excluded if deregistered with **<mode>=0**. To register or deregister an indicator the **AT+CIND** write command requires to type the value **<mode>=1** or **0** exactly at the position where the indicator is located in the list. This is not necessary with **AT^SIND** which allows to specify indicators by name. See examples below.
  - The presentation of the registered indicators must be enabled with **AT+CMER**.

### Syntax

```

Test Command
AT+CIND=?
Response(s)
+CIND: (<indDescr>, list of supported <indValue>s)[, (<indDescr>, list of supported <indValue>s)[,
...]]
OK

Read Command
AT+CIND?
Response(s)
+CIND: <indValue>[, <indValue>[, ...]]
OK
ERROR
+CME ERROR: <err>

Write Command
AT+CIND=<mode>[, <mode>[, ...]]
Response(s)
OK
ERROR
+CME ERROR: <err>

Reference(s)
GSM 07.07
PIN ASC0 MUX1 MUX2 MUX3 Charge Last
○ ● ● ● ● ○ ○ ○
    
```

### Parameter Description

**<indValue><sup>(num)</sup>**  
Integer type value, which shall be in range of corresponding **<indDescr>**

`<indDescr>^(str)`

String values and their `<indValue>` ranges.

More indications are available via `AT^SIND`. Therefore use of `AT^SIND` for control of all indications is recommended.

The following indications are accessible via `AT+CIND`:

“battchg”	Battery charge level 0..4 or 5 if no measuring is performed, e.g because no battery is connected. Also refer to <code>AT^SBC</code> .
“signal”	Signal quality (0..7) or (99) if not measurable The indicated value is the bit error rate of the signal received. Bit errors are estimated values. See also <code>AT+CSQ</code> .
“service”	Service availability (0-1) 0: Not registered to any network 1: Registered to home network or, if "roam"=1 then registered to another network
“sounder”	Sounder activity (0-1) Reports every event that causes the ME to generate a tone. Value 1 means for example: Incoming call - ME is ringing. Note that the URC "+CIEV: sounder" will be output only if ringing tones are activated with <code>AT^SRTC</code> . Waiting call - ME generates waiting call tone (if call waiting is enabled). Outgoing call - ME generates Call Progress tone. Outgoing call - ME generates BUSY tone. The value changes to 0 when the tone stops.
“message”	Unread short message at memory location <code>&lt;mem1&gt;</code> (0-1); refer to <code>AT+CPMS</code>
“call”	Call in progress (0-1). Indicator value is "1" if at least one call is in state "active" or "held".
“roam”	Roaming indicator (0-1) 0: Registered to home network or not registered 1: Registered to other network
“smsfull”	A short message memory storage in the MT has become full (1) or memory locations are available (0), i.e. range is (0-1)
“rsqi”	Received signal (field) strength (0..5) or (99) if not measurable 0: signal strength $\leq$ -112 dbm 1-4: signal strength in 15 dbm steps 5: signal strength $\geq$ -51 dbm Received signal (field) strength can also be obtained with <code>AT+CSQ</code> . However, the signal strength is scaled to value range 0..31 by this command.

`<mode>^(num)`

0	Indicator is deregistered. The indicator will not be presented as "+CIEV" URC, but can be queried with <code>AT+CIND?</code> .
[1](&F)(P)	Indicator is registered, indicator event report allowed.

### Note

- Due to its restrictive value range, indicator "call" does not clearly reflect specific call states (such as alerting, active, held etc.), but rather serves to trigger the application to retrieve the new call status from the list of current calls with the AT commands `AT+CLCC` or `AT^SCNI`.

### Examples

EXAMPLE 1

```
^SYSSTART
AT+CPIN=9999
```

OK	
AT+CIND?	
+CIND: 5,99,1,0,0,0,0,0	The battery is either full or no battery is connected to the ME. The bit error rate of the signal quality is not available (since there is no call in progress). The ME is registered to its home network.
OK	
AT+CMER=2,0,0,2	Now activate the Indicator Event Report with <a href="#">AT+CMER</a> .
OK	
+CIEV: battchg,5	
+CIEV: signal,99	
+CIEV: service,1	
+CIEV: sounder,0	
+CIEV: message,0	
+CIEV: call,0	
+CIEV: roam,0	
+CIEV: smsfull,0	
+CIEV: rssi,5	Full receive signal strength.
ATD0123456;	Make a call.
OK	
+CIEV: sounder,1	A set of "+CIEV" URCs is received.
+CIEV: call,1	
+CIEV: sounder,0	
+CIEV: call,0	Called party hangs up.
NO CARRIER	
AT+CIND=,,,0,,0	Deregister the indicators "sounder" and "call".
OK	
ATD0123456;	Dial the same call.
OK	This time, no URCs are displayed.
NO CARRIER	Called party hangs up.

EXAMPLE 2

Deactivation of indicator "sounder" via [AT+CIND](#)

AT+CIND?	Query the current status of indicators.
+CIND: 5,99,1,0,1,0,0,0,4	
OK	
AT+CIND=,,,0	To deactivate indicator "sounder" (= fourth item in list of indicators).
OK	

EXAMPLE 3

Deactivation of indicator "sounder" via [AT^SIND](#)

AT^SIND="sounder",0	To deactivate indicator "sounder".
^SIND: sounder,0,0	
OK	

### 3.3 AT^SIND Extended Indicator Control

Designed for extended event indicator control [AT^SIND](#)

- offers greater flexibility than the standard command [AT+CIND](#),
- offers several extra indicators,
- can show the current status of all indicators supported by [AT+CIND](#) and [AT^SIND](#),
- can be used to register or deregister the indicators of both commands,
- displays all indicator event reports via "+CIEV" URCs.

Presentation mode of the generated URCs is controlled via [AT+CMER](#).

The [AT^SIND](#) read command provides a list of all indicators supported by [AT+CIND](#) and [AT^SIND](#). Each indicator is represented with its registration mode and current value.

The [AT^SIND](#) write command can be used to select a single indicator in order to modify its registration and to view the current value.

#### Syntax

```

Test Command
AT^SIND=?
Response(s)
^SIND: (<indDescr>, list of supported <indValue>s)[, (<indDescr>, list of supported <indValue>s)[,
...]], (list of supported <mode>s)
OK

Read Command
AT^SIND?
Response(s)
^SIND: <indDescr>, <mode>, <indValue>
[^SIND: <indDescr>, <mode>, <indValue>]
...
OK
ERROR
+CME ERROR: <err>

Write Command
AT^SIND=<indDescr>, <mode>
Response(s)
^SIND: <indDescr>, <mode>, <indValue>
OK
ERROR
+CME ERROR: <err>

Reference(s)
--
PIN    ASC0   MUX1   MUX2   MUX3   Charge  Last
○      ●      ●      ●      ●      ○       ○       ○
    
```

#### Unsolicited Result Code

Format of the standard indicator:

+CIEV: <indDescr>, <indValue>

Value related to an indicator has changed.

### Parameter Description

`<indDescr>`<sup>(str)</sup>

String values and their `<indValue>` ranges.

All indicators supported by `AT+CIND` are accessible with this command, too. A detailed description of these indicators can be found there.

The following indicators are accessible via `AT^SIND` only:

"ciphcall"

Ciphering Status Change Indication

0 Current call or SMS is not ciphered.

1 Current call or SMS is ciphered.

As stated in GSM specifications 02.07 and 02.09 the ciphering indicator feature allows the TC35i to detect that ciphering is not switched on and to indicate this to the user.

The ciphering indicator feature may be disabled by the home network operator setting data in the "administrative data" field (EF<sub>AD</sub>) in the SIM, as defined in GSM 11.11.

If this feature is not disabled by the SIM, then whenever a connection is in place, which is, or becomes unenciphered, an indication shall be given to the user. This enables the user's decision how to proceed.

Read command returns valid ciphering status only if a call is in progress or active.

If EF<sub>AD</sub> setting disables the ciphering indicator feature read command always indicates a ciphered link and no URC presentation will take place.

The following restrictions apply if the same serial channel is used for `AT^SIND` "ciphcall" indication and for the action triggering this URC. In general, the recommended solution is to use a dedicated channel for all status signalling via URCs.

- If an unciphered mobile originated SMS is performed, `AT^SIND` "ciphcall" URCs on the same serial channel will be issued after the related "OK" and indicate the ciphering state at *this* time. Because the SMS is already sent at this time, two URCs will be issued on this channel, but both are indicating that ciphering is enabled.
- If an unciphered mobile originated data call is performed, `AT^SIND` "ciphcall" URCs on the same serial channel will be issued after the interface is not longer blocked by the call (call is released or temporarily stopped) and indicate the ciphering state at *this* time.

`<indValue>`<sup>(num)</sup>

Integer type value in the range stated above for the corresponding `<indDescr>`.

`<mode>`<sup>(num)</sup>

0

Indicator is deregistered, i.e. no such indicator event report (URC) will be issued. `<mode>=0` is power-up and factory default of indicators defined by `AT^SIND` only.

1

Indicator is registered.

- Indicator event reports are controlled via `AT+CMER`.
- All indicators can be registered or deregistered via `AT^SIND`, but different default settings apply: Power-up and factory default of the indicators supported by `AT+CIND` is `<mode>=1`, while, as stated above, indicators defined by `AT^SIND` only are set to `<mode>=0`.

2

Query the registration status and the current value of a single indicator type.

### 3.4 AT+CEER Extended Error Report

AT+CEER returns an extended error report regarding the reason of the last

- call release
- failure to set up a call (both mobile originated or terminated)
- failure to modify a call by using Supplementary Services
- failed attempt to activate, register, query, deactivate or deregister a Supplementary Service

The release cause report is presented in numeric format. Default output in case of a non-error-situation is +CEER: 0,0,0. A description associated with each number can be found in the tables given in the following sub-clauses and the relevant GSM specifications.

The first parameter <locationID> serves to locate the other two parameters. Depending on the failure or release cause either <reason> or <ssRelease> are applicable, i.e. if <reason> ≠ 0, then <ssRelease> = 0. Vice versa, if <reason> = 0, then <ssRelease> may be ≠ 0.

AT+CEER is not available for data calls, please use AT+SI=1 instead.

#### Syntax

<p>Test Command</p> <pre>AT+CEER=?</pre> <p>Response(s)</p> <pre>OK ERROR +CME ERROR</pre>	<p>Exec Command</p> <pre>AT+CEER</pre> <p>Response(s)</p> <pre>+CEER: &lt;locationID&gt;, &lt;reason&gt;, &lt;ssRelease&gt; OK ERROR +CME ERROR</pre>																
<p>Reference(s)</p> <pre>GSM 07.07</pre>	<table border="1"> <thead> <tr> <th>PIN</th> <th>ASC0</th> <th>MUX1</th> <th>MUX2</th> <th>MUX3</th> <th>Charge</th> <th></th> <th>Last</th> </tr> </thead> <tbody> <tr> <td>●</td> <td>●</td> <td>●</td> <td>●</td> <td>●</td> <td>○</td> <td>○</td> <td>○</td> </tr> </tbody> </table>	PIN	ASC0	MUX1	MUX2	MUX3	Charge		Last	●	●	●	●	●	○	○	○
PIN	ASC0	MUX1	MUX2	MUX3	Charge		Last										
●	●	●	●	●	○	○	○										

#### Parameter Description

<locationID><sup>(num)</sup>

Location ID as number code. Location IDs are listed in Section 3.4.1, Cause Location ID for the extended error report. Each ID is related with another table that contains a list of <reason>s or <ssRelease>s.

<reason><sup>(num)</sup>

Reason for last call release as number code. The number codes are listed in several tables, sorted by different categories in the following subclauses. The tables can be found proceeding from the Location ID given in Section 3.4.1, Cause Location ID for the extended error report.

<ssRelease><sup>(num)</sup>

Release cause for last Supplementary Service call (listed in Section 3.4.9, GSM Release cause for Supplementary Service Call) or last call related use of a Supplementary Service (listed in Section 3.4.10, Proprietary release cause for Call-related Supplementary Services (CRSS)).



## Examples

### EXAMPLE 1

<pre>ATD"01751223344"; NO CARRIER AT+CEER +CEER: 8,21,0 OK</pre>	<p>A mobile originated call is rejected by the remote party. Call setup is terminated with NO CARRIER. To check the cause, the caller enters AT+CEER. The Location ID 8 in Section 3.4.1 points to Section 3.4.6, where 21 = "Call rejected". 0 = "No error" refers to parameter &lt;ssRelease&gt; that is not applicable.</p>
--	--

### EXAMPLE 2

The user attempts to activate call barring, but uses a wrong password.

<pre>AT+clck=oi,1,"0000",3 +CME ERROR: incorrect password AT+CEER +CEER: 35,0,38 OK</pre>	<p>The Location ID 35 in Section 3.4.1 points to Section 3.4.9, where 38 = "NegativePWCheck" may mean that a wrong password was tried for the first time. 0 = "No error" refers to parameter &lt;reason&gt; that is not applicable.</p>
---	---

## 3.4.1 Cause Location ID for the extended error report

ID	Description
0	No error (default)
1	Proprietary L2 cause
2	GSM cause for L3 Radio Resource Sublayer (GSM 04.08 annex F)
3	Proprietary cause for L3 Radio Resource Sublayer
4	GSM cause for L3 Mobility Management (GSM 04.08 annex G)
5	Proprietary cause for L3 Mobility Management
6	GSM cause for L3 Mobility Management via MMR-SAP (GSM 04.08 annex G)
7	Proprietary cause for L3 Mobility Management via MMR-SAP
8	GSM cause for L3 Call Control (GSM 04.08 10.5.4.11 and annex H)
9	Proprietary cause for L3 Call Control
11	Proprietary cause for L3 Advice of Charge Entity
12	GSM cause for L3 SMS CP Entity
13	Proprietary cause for L3 SMS CP Entity
14	GSM cause for L3 SMS RL Entity
15	Proprietary cause for L3 SMS RL Entity
16	GSM cause for L3 SMS TL Entity
17	Proprietary cause for L3 SMS TL Entity
18	Proprietary cause for DSM Entity
21	GSM cause for L3 Call-related Supplementary Services
22	Proprietary cause for L3 Call-related Supplementary Services
32	Proprietary cause for Supplementary Services Entity
33	Proprietary cause for Supplementary Services Manager
34	Network cause for Supplementary Services (GSM 04.08 10.5.4.11 and annex H)
35	Supplementary Services network error (GSM 04.80 3.6.6)

ID	Description
50	GSM cause for Session Management (GSM 04.08 annex I)
51	Proprietary cause for Session Management
127	Proprietary cause for protocol module or other local cause
128	Supplementary Services general problem (GSM 04.80 3.6.7)
129	Supplementary Services invoke problem (GSM 04.80 3.6.7)
130	Supplementary Services result problem (GSM 04.80 3.6.7)
131	Supplementary Services error problem (GSM 04.80 3.6.7)
242	Proprietary cause for Link Management

### 3.4.2 GSM release cause for L3 Radio Resource (RR)

Number	Description
0	Normal event
1	Abnormal release, unspecified
2	Abnormal release, channel unacceptable
3	Abnormal release, timer expired
4	Abnormal release, no activity on the radio path
5	Pre-emptive release
8	Handover impossible, timing advance out of range
9	Channel mode unacceptable
10	Frequency not implemented
65	Call already cleared
95	Semantically incorrect message
96	Invalid mandatory information
97	Message type non-existent or not implemented
98	Message type not compatible with protocol state
100	Conditional information element error
101	No cell allocation available
111	Protocol error unspecified

### 3.4.3 Dfcdf]YHJf mrelease cause for L3 Radio Resource (RR)

Number	Description
1	Racchs not answered
2	Racchs rejected
3	Access class of the SIM is barred by the network provider
4	SABM failure
5	Radio link counter expiry or PerformAbnormalRelease
6	Confirm ABORT of the MM
7	Respond to DEACT REQ

Number	Description
8	Loss of coverage
9	Reestablishment not possible

### **3.4.4 GSM release cause for Mobility Management (MM) or Session Management (SM)**

Number	Description
Causes related to MS identification	
2	IMSI unknown in HLR
3	Illegal MS
4	IMSI unknown in VLR
5	IMEI not accepted
6	Illegal ME
Cause related to subscription options	
11	PLMN not allowed
12	Location Area not allowed
13	Roaming not allowed in this location area
Causes related to PLMN specific network failures and congestion	
17	Network failure
22	Congestion
Causes related to nature of request	
32	Service option not supported
33	Requested service option not subscribed
34	Service option temporarily out of order
36	Regular PDP context deactivation
38	Call cannot be identified
Causes related to invalid messages	
95	Semantically incorrect message
96	Invalid mandatory information
97	Message type non-existent or not implemented
98	Message not compatible with protocol state
99	Information element non-existent or not implemented
100	Conditional information element error
101	Messages not compatible with protocol state
111	Protocol error, unspecified

### 3.4.5 DfcdfJYHUmrelease cause for L3 Mobility Management (MM)

Number	Description
1	No SIM available
8	No MM connection
9	Authentication failure
11	MM performs detach
17	Registration failed and will be re-attempted in a short term
18	CM connection establishment failed
19	Registration failed and will be re-attempted in a long term
20	RR connection is released
21	MS tries to register
22	SPLMN is not available
23	An MTC is in progress
24	A PLMN scan is in progress

### 3.4.6 GSM release cause for L3 Call Control (CC)

Number	Description
0	No error
Normal class	
1	Unassigned (unallocated) number
3	No route to destination
6	Channel unacceptable
8	Operator determined barring
16	Normal call clearing
17	User busy
18	No user responding
19	User alerting, no answer
21	Call rejected
22	Number changed
25	Pre-emption
26	Non-selected user clearing
27	Destination out of order
28	Invalid number format (incomplete number)
29	Facility rejected
30	Response to STATUS ENQUIRY
31	Normal, unspecified
Resource unavailable class	
34	No circuit/channel available
38	Network out of order
41	Temporary failure

Number	Description
42	Switching equipment congestion
43	Access information discarded
44	Requested circuit/channel not available
47	Resource unavailable, unspecified
Service or option not available class	
49	Quality of service unavailable
50	Requested facility not subscribed
55	Incoming calls barred within the CUG
57	Bearer capability not authorized
58	Bearer capability not presently available
63	Service or option not available, unspecified
Service or option not implemented	
65	Bearer service not implemented
68	ACM equal or greater than ACMmax
69	Requested facility not implemented
70	Only restricted digital information bearer capability is available
79	service or option not implemented, unspecified
Invalid message (e.g. parameter out of range) class	
81	Invalid transaction identifier value
87	User not member of CUG
88	Incompatible destination
91	Invalid transit network selection
95	Semantically incorrect message
Protocol error (e.g. unknown message) class	
96	Invalid mandatory information
97	Message type non-existent or not implemented
98	Message type not compatible with protocol state
99	Information element non-existent or not implemented
100	Conditional information element error
101	Message not compatible with protocol
102	Recovery on timer expiry
111	Protocol error, unspecified
Interworking class	
127	Interworking, unspecified

### 3.4.7 DfcdfJYHf mrelease cause for L3 Call Control (CC)

Number	Description
1	Call dropped
2	Service not available
3	Hold procedure not available

Number	Description
4	Temporary no service, previous procedure not yet finished
5	No speech service available
6	Call reestablishment procedure active
7	Mobile received a release (complete) message during a modify procedure (modify reject)
8	Call clearing, because loss of radio connection, if no reestablishment is allowed (call not active)
10	Number not included in FDN list
Notifications	
300	Called party barred incoming call

### 3.4.8 Dfcdf]YHf mrelease cause for L3 Advice of Charge (AOC)

Number	Description
1	SIM data not available
2	SIM does not support AOC
3	SIM data access error
4	ACM limit almost reached ACM range overflow
5	ACM range overflow

### 3.4.9 GSM Release cause for Supplementary Service Call

Number	Description
0	No error (default)
1	UnknownSubscriber
9	IllegalSubscriber
10	BearerServiceNotProvisioned
11	TeleserviceNotProvisioned
12	IllegalEquipment
13	CallBarred
15	CUGReject
16	IllegalSSOperation
17	SSErrorStatus
18	SSNotAvailable
19	SSSubscriptionViolation
20	SSIncompatibility
21	FacilityNotSupported
27	AbsentSubscriber
29	ShortTermDenial
30	LongTermDenial
34	SystemFailure
35	DataMissing

Number	Description
36	UnexpectedDataValue
37	PWRegistrationFailure
38	NegativePWCheck
43	NumberOfPWAttemptsViolation
71	UnknownAlphabet
72	USSDBusy
126	MaxNumsOfMPTYCallsExceeded
127	ResourcesNotAvailable
General Problem Codes	
300	Unrecognized Component
301	Mistyped Component
302	Badly Structured Component
Invoke Problem Codes	
303	Duplicate Invoke ID
304	Unrecognized Operation
305	Mistyped Parameter
306	Resource Limitation
307	Initiating Release
308	Unrecognized Linked ID
309	Linked Response Unexpected
310	Unexpected Linked Operation
Return Result Problem Codes	
311	Unrecognize Invoke ID
312	Return Result Unexpected
313	Mistyped Parameter
Return Error Problem Codes	
314	Unrecognized Invoke ID
315	Return Error Unexpected
316	Unrecognized Error
317	Unexpected Error
318	Mistyped Parameter

### 3.4.10 DfcdfJYHf release cause for Call-related Supplementary Services (CRSS)

Number	Description
0	ECT procedure failed (timer expired)
1	Call has been cleared without receiving an answer to ECT request
2	Initial conditions not fulfilled (one active, one held call)
3	Received "return error"
4	Call has been cleared without receiving an answer to CCBS request

Number	Description
5	Initial conditions for CCBS not fulfilled (Idle CRSS)
Causes related to nature of request	
25	LLC or SNDTCP failure
26	Insufficient resources
27	Unknown or missing access point name
28	Unknown PDP address or PDP type
29	User authentication failed
30	Activation rejected by GGSN
31	Activation rejected, unspecified
32	Service option not supported
33	Requested service option not subscribed
34	Service option temporarily out of order
35	NSAPI already used
36	Regular PDP context deactivation
37	QoS not accepted
38	Network failure
39	Reactivation requested
40	Feature not supported
Causes related to invalid messages	
81	Invalid transaction identifier value
95	Semantically incorrect message
96	Invalid mandatory information
97	Message type non-existent or not implemented
98	Message type not compatible with protocol state
99	Information element non-existent or not implemented
100	Conditional information element error
101	Message not compatible with protocol
111	Protocol error, unspecified



## 3.5 ATS18 Extended call release report



ATS18 controls the presentation of extended call release reports for circuit switched fax and data calls. Extended call release reports related to voice calls are controlled via [AT+CEER](#).

The call release report is presented in numeric format and shows as follows:

+CAUSE: <locationID>:<reason>

If enabled the message will be reported every time a fax or data call is released or fails to be established.

### Syntax

Read Command																	
ATS18?																	
Response(s)																	
<n>																	
OK																	
Write Command																	
ATS18=<n>																	
Response(s)																	
OK																	
ERROR																	
Reference(s)																	
V.250																	
	<table border="1"> <thead> <tr> <th>PIN</th> <th>ASC0</th> <th>MUX1</th> <th>MUX2</th> <th>MUX3</th> <th>Charge</th> <th></th> <th>Last</th> </tr> </thead> <tbody> <tr> <td><input type="radio"/></td> <td><input checked="" type="radio"/></td> <td><input checked="" type="radio"/></td> <td><input type="radio"/></td> <td><input type="radio"/></td> <td><input type="radio"/></td> <td><input type="radio"/></td> <td><input type="radio"/></td> </tr> </tbody> </table>	PIN	ASC0	MUX1	MUX2	MUX3	Charge		Last	<input type="radio"/>	<input checked="" type="radio"/>	<input checked="" type="radio"/>	<input type="radio"/>	<input type="radio"/>	<input type="radio"/>	<input type="radio"/>	<input type="radio"/>
PIN	ASC0	MUX1	MUX2	MUX3	Charge		Last										
<input type="radio"/>	<input checked="" type="radio"/>	<input checked="" type="radio"/>	<input type="radio"/>	<input type="radio"/>	<input type="radio"/>	<input type="radio"/>	<input type="radio"/>										

### Parameter Description

<n><sup>(num)(&W)(&V)</sup>

An odd number enables the presentation of the extended call release report. Any even number disables this feature.

0<sup>(&F)</sup>...255

<locationID><sup>(num)</sup>

Location ID as number code, see also <locationID> of [AT+CEER](#).

Location IDs are listed in Section 3.4.1, [Cause Location ID for the extended error report](#). Each ID is related to another table that contains a list of <reason>s.

<reason><sup>(num)</sup>

Reason for last call release as number code (see also <reason> of [AT+CEER](#)).

<reason> numbers and the associated descriptions are listed in several tables, sorted by different categories at [AT+CEER](#). The tables can be found proceeding from the Location IDs listed in Section 3.4.1, [Cause Location ID for the extended error report](#).

## Examples

### EXAMPLE 1

<pre>ATS18=1 OK ATD03012345678 +CAUSE: 8:17 BUSY</pre>	<p>Enables the presentation of extended call release reports.</p> <p>Now, a mobile originated data call fails. An extended error report is output, followed by the result code BUSY. The Location ID 8 stated in Section 3.4.1 points to Section 3.4.6, with 17 = "User busy".</p>
--	--



### EXAMPLE 2

<pre>ATS18=1 OK ATD03012345678 CONNECT 9600/RLP Hello, . . . . +++ +CAUSE: 8:16 NO CARRIER</pre>	<p>Enables the presentation of extended call release reports.</p> <p>Now, a mobile originated data call is set up.</p> <p>Call ends after remote party hung up. Normal call release is reported, followed by the result code NO CARRIER. The Location ID 8 stated in Section 3.4.1 points to Section 3.4.6, with 16 = "Normal call clearing".</p>
--	---

## 3.6 AT+CPAS Mobile equipment activity status

The `AT+CPAS` execute command indicates the activity status of the ME.

### Syntax

Test Command <code>AT+CPAS=?</code> Response(s) <code>+CPAS: (list of supported &lt;pas&gt;s)</code> <code>OK</code>	Exec Command <code>AT+CPAS</code> Response(s) <code>+CPAS: &lt;pas&gt;</code> <code>OK</code>	Reference(s) <code>GSM 07.07</code>	<table border="1"> <tr> <th>PIN</th> <th>ASC0</th> <th>MUX1</th> <th>MUX2</th> <th>MUX3</th> <th>Charge</th> <th></th> <th>Last</th> </tr> <tr> <td><input type="radio"/></td> <td><input checked="" type="radio"/></td> <td><input checked="" type="radio"/></td> <td><input checked="" type="radio"/></td> <td><input checked="" type="radio"/></td> <td><input type="radio"/></td> <td><input type="radio"/></td> <td><input type="radio"/></td> </tr> </table>	PIN	ASC0	MUX1	MUX2	MUX3	Charge		Last	<input type="radio"/>	<input checked="" type="radio"/>	<input checked="" type="radio"/>	<input checked="" type="radio"/>	<input checked="" type="radio"/>	<input type="radio"/>	<input type="radio"/>	<input type="radio"/>
PIN	ASC0	MUX1	MUX2	MUX3	Charge		Last												
<input type="radio"/>	<input checked="" type="radio"/>	<input checked="" type="radio"/>	<input checked="" type="radio"/>	<input checked="" type="radio"/>	<input type="radio"/>	<input type="radio"/>	<input type="radio"/>												

### Parameter Description

<pas> <sup>(num)</sup>	
0	Ready
3	Incoming call (ringing)
4	Call in progress or call hold

## 3.7 AT+WS46 Select wireless network

### Syntax

<p>Test Command</p> <pre>AT+WS46=?</pre> <p>Response(s)</p> <pre>+WS46: (list of supported&lt;n&gt;s) OK</pre>																	
<p>Read Command</p> <pre>AT+WS46?</pre> <p>Response(s)</p> <pre>&lt;n&gt; OK</pre>																	
<p>Write Command</p> <pre>AT+WS46=&lt;n&gt;</pre> <p>Response(s)</p> <pre>OK ERROR +CME ERROR</pre>																	
<p>Reference(s)</p> <pre>GSM 07.07</pre>	<table border="1"> <thead> <tr> <th>PIN</th> <th>ASC0</th> <th>MUX1</th> <th>MUX2</th> <th>MUX3</th> <th>Charge</th> <th></th> <th>Last</th> </tr> </thead> <tbody> <tr> <td><input type="radio"/></td> <td><input checked="" type="radio"/></td> <td><input checked="" type="radio"/></td> <td><input checked="" type="radio"/></td> <td><input checked="" type="radio"/></td> <td><input type="radio"/></td> <td><input type="radio"/></td> <td><input type="radio"/></td> </tr> </tbody> </table>	PIN	ASC0	MUX1	MUX2	MUX3	Charge		Last	<input type="radio"/>	<input checked="" type="radio"/>	<input checked="" type="radio"/>	<input checked="" type="radio"/>	<input checked="" type="radio"/>	<input type="radio"/>	<input type="radio"/>	<input type="radio"/>
PIN	ASC0	MUX1	MUX2	MUX3	Charge		Last										
<input type="radio"/>	<input checked="" type="radio"/>	<input checked="" type="radio"/>	<input checked="" type="radio"/>	<input checked="" type="radio"/>	<input type="radio"/>	<input type="radio"/>	<input type="radio"/>										

### Parameter Description

<n> <sup>(num)</sup>	Description
12	GSM digital cellular

## 4. Serial Interface Control Commands

The AT Commands described in this chapter allow the external application to determine various settings related to the TC35i's serial interface.

### 4.1 AT\Q Flowcontrol

#### Syntax

Exec Command							
AT\Q[<n>]							
Response(s)							
OK							
Reference(s)		PIN    ASC0    MUX1    MUX2    MUX3    Charge        Last					
--		<input type="radio"/> <input checked="" type="radio"/> <input type="radio"/> <input type="radio"/> <input type="radio"/> <input type="radio"/> <input type="radio"/> <input type="radio"/>					

#### Parameter Description

<n> (num)(&W)(&V)	
[0](&F)	disable flow control
1	XON/XOFF software flow control
2	only CTS by DCE
3	RTS/CTS hardware flow control Recommended for the following procedures: incoming or outgoing data calls, fax calls, MUX mode. Often, the initialization routine of Fax programs includes enabling RTS/CTS handshake, eliminating the need to issue AT\Q3 once again.

#### Notes

- When using XON/XOFF flow control (AT\Q1) in online mode, +++ should not be used while the data transmission is paused with XOFF. Before entering the command mode with +++ the paused transmission should be resumed using the XON character.
- For compatibility reasons, the AT\Q command can be used in Multiplex mode, though the settings will not take effect. However, be aware that whenever you use the AT\Q write command in Multiplex mode and then save the current configuration to the user profile with AT&W, the changed AT\Q setting will become active after restart.
- Flow control can also be set using AT+IFC.

## 4.2 AT&C Set circuit Data Carrier Detect (DCD) function mode

The [AT&C](#) command determines how the state of circuit 109 (DCD) relates to the detection of received line signal from the distant end.

### Syntax

Exec Command									
AT&C[<value>]									
Response(s)									
OK									
Reference(s)		PIN	ASC0	MUX1	MUX2	MUX3	Charge		Last
V.250		<input type="radio"/>	<input checked="" type="radio"/>	<input checked="" type="radio"/>	<input checked="" type="radio"/>	<input checked="" type="radio"/>	<input type="radio"/>	<input type="radio"/>	<input type="radio"/>

### Parameter Description

<value> <sup>(num)(&amp;W)(&amp;V)</sup>	
[0]	DCD line is always ON
1 <sup>(&amp;F)</sup>	DCD line is ON in the presence of data carrier only

## 4.3 AT&D Set circuit Data Terminal Ready (DTR) function mode

### Syntax

Exec Command																	
AT&D[<value>]																	
Response(s)																	
OK																	
Reference(s)	<table border="1"> <tr> <td>PIN</td> <td>ASC0</td> <td>MUX1</td> <td>MUX2</td> <td>MUX3</td> <td>Charge</td> <td></td> <td>Last</td> </tr> <tr> <td><input type="radio"/></td> <td><input checked="" type="radio"/></td> <td><input checked="" type="radio"/></td> <td><input checked="" type="radio"/></td> <td><input checked="" type="radio"/></td> <td><input type="radio"/></td> <td><input type="radio"/></td> <td><input type="radio"/></td> </tr> </table>	PIN	ASC0	MUX1	MUX2	MUX3	Charge		Last	<input type="radio"/>	<input checked="" type="radio"/>	<input checked="" type="radio"/>	<input checked="" type="radio"/>	<input checked="" type="radio"/>	<input type="radio"/>	<input type="radio"/>	<input type="radio"/>
PIN	ASC0	MUX1	MUX2	MUX3	Charge		Last										
<input type="radio"/>	<input checked="" type="radio"/>	<input checked="" type="radio"/>	<input checked="" type="radio"/>	<input checked="" type="radio"/>	<input type="radio"/>	<input type="radio"/>	<input type="radio"/>										
V.250																	

### Command Description

This parameter determines how the TA responds when circuit 108/2 (DTR) is changed from ON to OFF during data mode.

### Parameter Description

<value> <sup>(num)(&amp;W)(&amp;V)</sup>	
[0]	TA ignores status of DTR.
1	ON->OFF on DTR: Change to command mode while retaining the connected call.
2 <sup>(&amp;F)</sup>	ON->OFF on DTR: Disconnect data call, change to command mode. During state DTR = OFF is auto-answer off.

## 4.4 AT%D Automatic Dial on DTR Line Activation

**AT%D** controls automatic dialling on DTR line activation.

A more generic way to control the TC35i via its DTR line is available with **AT^SCFG**, refer to parameter `<AutoExecATC>`.

If automatic dialling is enabled and the DTR line switches from OFF to ON state, the ME attempts to set up an outgoing call to the number stored at the first index of the "ME" phone book, or using telephone number '112' in case of an emergency call.

To suppress arbitrary call releases on DTR deactivation setting of **AT&D0** is strongly recommended.

If enabled, DTR activation triggers a dial command (**ATD**) as though it were entered by a TE. Therefore if in this situation characters are entered on the same serial channel the ongoing dial command will be terminated (user break).

When a call setup starts all other active or held calls are dismissed.

Repeated DTR activation events are ignored while call setup is in progress or during a call established by DTR activation. Also all DTR activation events during multiplex mode (**AT+CMUX**) are discarded. The Exec command is not supported during multiplex mode.

If several AT commands are entered on the same line **AT%D** needs to be the last one.

To enable auto dialling for data and voice calls after ME's power on it is necessary to disable PIN authorization with the command **AT+CLCK="SC",0,<password>**. To prevent misuse of this unprotected SIM card it is recommended to limit its network facilities. For details refer to the "FD" parameter of **AT+CLCK**.

If dialling starts on DTR line activation, possible responses are as though the dial command were entered by a TE, for instance:

- OK  
If successfully connected and voice call
- CONNECT<text>  
If successfully connected and non-voice call. <text> is sent out if parameter setting is **ATX>0**. TA switches to data state.
- +CME ERROR: SIM not inserted  
SIM card is needed to set up data and voice calls.
- +CME ERROR: SIM PIN required  
PIN is required to set up data and voice calls.
- +CME ERROR: not found  
Phone book entry is required for data and voice calls, but no telephone number is provided.
- NO DIALTONE  
If there is no dialtone and parameter setting **ATX2** or **ATX4**.
- BUSY  
If busy and parameter setting **ATX3** or **ATX4**.
- NO CARRIER  
If a connection cannot be set up or call is finished by other party.

### Syntax

Test Command

**AT%D=?**

Response(s)

%D: (list of supported `<mode>`s), (list of supported `<dialType>`s)

OK

Read Command

**AT%D?**

Response(s)

%D: `<mode>`, `<dialType>`

OK



Exec Command

AT%D[<mode>[<dialType>]]

Response(s)

OK  
 +CME ERROR: invalid characters in text string  
 Invalid parameter.  
 +CME ERROR: operation not supported  
 No physical DTR signal line is supported for the serial channel or no access to the CSD transmission unit is supported for the serial channel but a data call is requested (i.e. no ";" is appended, see below). However, data calls are applicable on serial channel 0 only.  
 +CME ERROR: operation temporary not allowed  
 Command is not supported during multiplex mode (AT+CMUX).

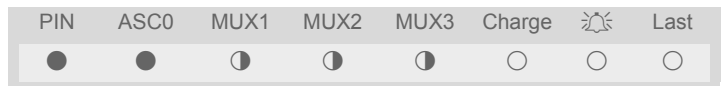

**Parameter Description**

<mode><sup>(num)(&W)</sup>

Auto dial state on DTR activation (OFF-ON transition). Additional functionality is available with AT^SCFG, e.g. sending a short message (SMS) on DTR activation can be done with parameter <AutoExecATC> set to "AT+CMSS=1".

- [0]<sup>(&F)</sup> Disable functionality.
- 1 Enable dialling of the telephone number located at index "1" in the "ME" phone book. If <dialType> is "!" an emergency call is set up. Refer to AT+CPBS and AT+CPBW.

<dialType><sup>(str)(&W)</sup>

Determine type of performed dial.

- [""]<sup>(&F)</sup> If omitted performed dial command leads to a data call.
- "," Performed dial command leads to a voice call.
- "! " Dial command leads to an emergency call, i.e. ATD "112"; is performed. No SIM card needs to be inserted in this case.  
**CAUTION!**  
 AT%D! setting especially in conjunction with AT&W can easily lead to erroneous emergency call setups.

**Example**

Create an entry at the first location of the ME phonebook and enable automatic dial on DTR line activation. For details regarding phone book handling refer to AT+CPBS and AT+CPBW.

```
AT+CPBS="ME"           Select ME phone book
OK
AT+CPBW=1,"+4977777777",145,"Helpdesk"  Store phone number to dialed automatically when
OK                                           DTR is toggled.
AT%D1;           Enable automatic dial.
OK
AT&W           Store setting in the user profile.
OK
```

If a DTR line activation has occurred:

```
OK           ATD command entry confirmation.
NO CARRIER  Called party hang up.
```

## 4.5 AT&S Set circuit Data Set Ready (DSR) function mode

The [AT&S](#) command determines how the TA sets circuit 107 (DSR) depending on the communication state of the TA interfacing TE.

### Syntax

Exec Command									
AT&S[<value>]									
Response(s)									
OK									
Reference(s)		PIN	ASC0	MUX1	MUX2	MUX3	Charge		Last
V.250		<input type="radio"/>	<input checked="" type="radio"/>	<input checked="" type="radio"/>	<input checked="" type="radio"/>	<input checked="" type="radio"/>	<input type="radio"/>	<input type="radio"/>	<input type="radio"/>

### Parameter Description

<value> <sup>(num)(&amp;W)(&amp;V)</sup>	
[0] <sup>(&amp;F)</sup>	DSR line is always ON
1	TA in command mode: DSR is OFF. TA in data mode: DSR is ON.

## 4.6 ATE Enable command echo

The [ATE](#) command determines whether or not the TA echoes characters received from TE during command state.

### Syntax

Exec Command									
ATE[<value>]									
Response(s)									
OK									
Reference(s)		PIN	ASC0	MUX1	MUX2	MUX3	Charge		Last
V.250		<input type="radio"/>	<input checked="" type="radio"/>	<input checked="" type="radio"/>	<input checked="" type="radio"/>	<input checked="" type="radio"/>	<input type="radio"/>	<input type="radio"/>	<input type="radio"/>

### Parameter Description

<value> <sup>(num)(&amp;W)(&amp;V)</sup>	
[0]	Echo mode off
1 <sup>(&amp;F)</sup>	Echo mode on

### Note

- In case of using the command without parameter, <value> is set to 0.

## 4.7 AT+ICF Serial Interface Character Framing

The command `AT+ICF` controls the serial interface character framing format and parity used for receiving and transmitting.

The following settings are supported:

- 7 bits, even parity, 1 stop bit (`AT+ICF=5,1`)
- 7 bits, odd parity, 1 stop bit (`AT+ICF=5,0`)
- 8 bits, even parity, 1 stop bit (`AT+ICF=2,1`)
- 8 bits, no parity, 1 stop bit (`AT+ICF=3`)
- 8 bits, odd parity, 1 stop bit (`AT+ICF=2,0`)
- 8 bits, no parity, 2 stop bits (`AT+ICF=1`)

### Syntax

<p>Test Command</p> <pre>AT+ICF=?</pre> <p>Response(s)</p> <pre>+ICF: (list of supported &lt;format&gt;s), (list of supported &lt;parity&gt;s) OK</pre>																	
<p>Read Command</p> <pre>AT+ICF?</pre> <p>Response(s)</p> <pre>+ICF: &lt;format&gt;[, &lt;parity&gt;] OK</pre>																	
<p>Write Command</p> <pre>AT+ICF=[&lt;format&gt;][, &lt;parity&gt;]</pre> <p>Response(s)</p> <pre>OK ERROR</pre>																	
<p>Reference(s)</p> <pre>V.250</pre>	<table border="1"> <tr> <td>PIN</td> <td>ASC0</td> <td>MUX1</td> <td>MUX2</td> <td>MUX3</td> <td>Charge</td> <td></td> <td>Last</td> </tr> <tr> <td><input type="radio"/></td> <td><input checked="" type="radio"/></td> <td><input type="radio"/></td> <td><input type="radio"/></td> <td><input type="radio"/></td> <td><input type="radio"/></td> <td><input type="radio"/></td> <td><input type="radio"/></td> </tr> </table>	PIN	ASC0	MUX1	MUX2	MUX3	Charge		Last	<input type="radio"/>	<input checked="" type="radio"/>	<input type="radio"/>	<input type="radio"/>	<input type="radio"/>	<input type="radio"/>	<input type="radio"/>	<input type="radio"/>
PIN	ASC0	MUX1	MUX2	MUX3	Charge		Last										
<input type="radio"/>	<input checked="" type="radio"/>	<input type="radio"/>	<input type="radio"/>	<input type="radio"/>	<input type="radio"/>	<input type="radio"/>	<input type="radio"/>										

### Parameter Description

`<format>`<sup>(num)(&W)(&V)</sup>

Specifies the character format used for receiving and transmitting.

1	8 data 0 parity 2 stop
2	8 data 1 parity 1 stop
[3]	8 data 0 parity 1 stop
5	7 data 1 parity 1 stop

`<parity>`<sup>(num)(&W)(&V)</sup>

Specifies the method of calculating the parity bit, if a parity bit is supported by `<format>`. If `<format>` does not support parity, this parameter has to be omitted.

0	odd
1	even



## Notes

- If **AT+ICF** modes 7E1 or 7O1 are set, the parity bit will by default not be transmitted over the air. If the remote party expects the parity bit to be transmitted, additional settings are required via **AT^STPB**.
- When using a bit rate of 300 bps there must be a delay of 500ms before entering the next command. At bit rates of 1200 bps the delay must be 300ms. For higher bit rates use of the default delay is sufficient.
- TC35i's autobaud feature detects the bit rate currently used by the TE. However, this detection suffers some limitations described in Section 4.10.1, **Autobauding**. If autobauding is enabled, the **AT+ICF** read command does not show the current character framing, but the character framing that will be used when autobauding is disabled.
- For compatibility reasons, the command can be used in Multiplex mode, though the settings will not take effect. Please note that changes made on multiplex channel 1 will be saved with **AT&W** and will become active when restarting the ME after **AT^SMSO**.
- To start the multiplexer it is necessary to set the character framing to 8 bits, no parity and 1 stop bit.
- If a **<format>** is selected without parity (e.g. **<format>=3**) and you try to activate a format with parity (e.g. **<format>=2**), you need to explicitly set the parameter **<parity>** (e.g. **AT+ICF=2,1**). Otherwise you will get '+CME ERROR: invalid index'. This is because for **<format>=3**, the parameter **<parity>** is set to the internal value 'no parity' which is not supported by **<format>=2**. (Remember that if an optional parameter is omitted for which no default is stated in this specification, the value of the parameter remains unchanged).

## 4.8 AT+IFC Set Flow Control separately for data directions

The command `AT+IFC` can be used to set or query the data flow control separately for each data direction. In contrast to this, flow control settings made with `AT\Q` are valid in both data directions.

### Syntax

<p>Test Command</p> <pre>AT+IFC=?</pre> <p>Response(s)</p> <pre>+IFC: (list of supported &lt;TEflowcontrol&gt;s), (list of supported &lt;TAflowcontrol&gt;s) OK</pre>																	
<p>Read Command</p> <pre>AT+IFC?</pre> <p>Response(s)</p> <pre>+IFC: &lt;TEflowcontrol&gt;, &lt;TAflowcontrol&gt; OK</pre>																	
<p>Write Command</p> <pre>AT+IFC=&lt;TEflowcontrol&gt;, &lt;TAflowcontrol&gt;</pre> <p>Response(s)</p> <pre>OK ERROR</pre>																	
<p>Reference(s)</p> <p>V.250</p>	<table border="1"> <tr> <td>PIN</td> <td>ASC0</td> <td>MUX1</td> <td>MUX2</td> <td>MUX3</td> <td>Charge</td> <td></td> <td>Last</td> </tr> <tr> <td><input type="radio"/></td> <td><input checked="" type="radio"/></td> <td><input type="radio"/></td> <td><input type="radio"/></td> <td><input type="radio"/></td> <td><input type="radio"/></td> <td><input type="radio"/></td> <td><input type="radio"/></td> </tr> </table>	PIN	ASC0	MUX1	MUX2	MUX3	Charge		Last	<input type="radio"/>	<input checked="" type="radio"/>	<input type="radio"/>	<input type="radio"/>	<input type="radio"/>	<input type="radio"/>	<input type="radio"/>	<input type="radio"/>
PIN	ASC0	MUX1	MUX2	MUX3	Charge		Last										
<input type="radio"/>	<input checked="" type="radio"/>	<input type="radio"/>	<input type="radio"/>	<input type="radio"/>	<input type="radio"/>	<input type="radio"/>	<input type="radio"/>										

### Parameter Description

<code>&lt;TEflowcontrol&gt;</code> <sup>(num)(&amp;W)</sup>	
Specifies the method used by the TE when receiving data from the TA.	
[0]	none
1	XON/XOFF, terminate flow control in the Cellular Engine
2	RTS line
3	XON/XOFF, evaluate flow control in the Cellular Engine and pass it through (over the air) to the opposite TE
<code>&lt;TAflowcontrol&gt;</code> <sup>(num)(&amp;W)</sup>	
Specifies the method used by the TA when receiving data from the TE.	
[0]	none
1	XON/XOFF
2	CTS line

---

**Notes**

- When using XON/XOFF flow control (`AT+IFC=1,x` or `AT+IFC=3,x`) in data mode, `+++` should not be used while the data transmission is paused with XOFF. Before entering the command mode with `+++` the paused transmission should be resumed using the XON character.
- For compatibility reasons, the `AT+IFC` command can be used in Multiplex mode, though the settings will not take effect. However, be aware that whenever you use the `AT+IFC` write command in Multiplex mode and then save the current configuration to the user profile with `AT&W`, the changed `AT+IFC` setting will become active after restart.

## 4.9 AT+ILRR Set TE-TA local rate reporting

The command [AT+ILRR](#) controls whether or not the intermediate result code "+ILRR" is transmitted from the DCE to the DTE.

### Syntax

<p>Test Command</p> <p>AT+ILRR=?</p> <p>Response(s)</p> <p>+ILRR: (list of supported &lt;value&gt;s)</p> <p>OK</p>																	
<p>Read Command</p> <p>AT+ILRR?</p> <p>Response(s)</p> <p>+ILRR: &lt;value&gt;</p> <p>OK</p>																	
<p>Write Command</p> <p>AT+ILRR=&lt;value&gt;</p> <p>Response(s)</p> <p>OK</p> <p>ERROR</p> <p>+CME ERROR</p>																	
<p>Reference(s)</p> <p>V.250</p>	<table border="1"> <thead> <tr> <th>PIN</th> <th>ASC0</th> <th>MUX1</th> <th>MUX2</th> <th>MUX3</th> <th>Charge</th> <th></th> <th>Last</th> </tr> </thead> <tbody> <tr> <td><input checked="" type="radio"/></td> <td><input checked="" type="radio"/></td> <td><input checked="" type="radio"/></td> <td><input type="radio"/></td> <td><input type="radio"/></td> <td><input type="radio"/></td> <td><input type="radio"/></td> <td><input type="radio"/></td> </tr> </tbody> </table>	PIN	ASC0	MUX1	MUX2	MUX3	Charge		Last	<input checked="" type="radio"/>	<input checked="" type="radio"/>	<input checked="" type="radio"/>	<input type="radio"/>	<input type="radio"/>	<input type="radio"/>	<input type="radio"/>	<input type="radio"/>
PIN	ASC0	MUX1	MUX2	MUX3	Charge		Last										
<input checked="" type="radio"/>	<input checked="" type="radio"/>	<input checked="" type="radio"/>	<input type="radio"/>	<input type="radio"/>	<input type="radio"/>	<input type="radio"/>	<input type="radio"/>										

### Intermediate Result Code

+ILRR: <rate>

Indicates port rate setting on connection.

### Command Description

The write command determines whether or not an intermediate result code of local rate is reported at connection setup. The rate is reported before the final result code of the connection is transmitted to the TE.

### Parameter Description

<value> <sup>(num)(&amp;W)(&amp;V)</sup>	
0 <sup>(&amp;F)</sup>	Disables reporting of local port rate
1	Enables reporting of local port rate

<rate> <sup>(num)</sup>	
port rate setting on connection (bps)	
0	Autobauding (see Section <a href="#">4.10.1, Autobauding</a> )
300	
600	
1200	
2400	



---

4800

9600

14400

19200

28800

38400

57600

115200

230400

(cannot be used in terminal version)

## 4.10 AT+IPR Set fixed local rate

The command [AT+IPR](#) can be used to set or query the TE-TA interface bit rate.

### Syntax

<p>Test Command</p> <p>AT+IPR=?</p> <p>Response(s)</p> <p>+IPR: (list of supported auto-detectable &lt;rate&gt;s) , (list of supported fixed-only &lt;rate&gt;s)</p> <p>OK</p>	
<p>Read Command</p> <p>AT+IPR?</p> <p>Response(s)</p> <p>+IPR: &lt;rate&gt;</p> <p>OK</p>	
<p>Write Command</p> <p>AT+IPR=&lt;rate&gt;</p> <p>Response(s)</p> <p>OK</p> <p>ERROR</p> <p>+CME ERROR</p>	
<p>Reference(s)</p> <p>V.250</p>	

### Command Description

The test command returns the values of the supported automatically detectable bit rates and the values of the supported fixed bit rates.

The read command returns the current bit rate of the interface.

The write command specifies the bit rate to be used for the interface. When you set a fixed-rate, make sure that both TE (DTE) and TA (DCE) are configured to the same rate. When you select autobauding, the TA will automatically recognize the bit rate currently used by the TE.

The setting is stored in the non-volatile memory and will be used whenever the engine is powered up again. However, in case of autobaud mode ([AT+IPR=0](#)) the detected TA bit rate will not be saved and, therefore, needs to be resynchronized after restarting the GSM engine (see Section [4.10.1, Autobauding](#)).

### Parameter Description

<rate> <sup>(num)&amp;V)</sup>	
bit rate per second (bps)	
0	Activates autobauding. See Section <a href="#">4.10.1, Autobauding</a> for further details.
300	
600	
1200	
2400	
4800	
9600	
14400	

---

19200	
28800	
38400	
57600	
115200	
230400	(Not available if product is TC35i Terminal)

### Notes

- Delivery value for `<rate>` is autobauding enabled (`AT+IPR=0`). It will not be restored with `AT&F`.
- The current setting of `AT+IPR` will be preserved when you download firmware (i.e. a firmware update does not restore the factory setting) or in the event of power failure.
- Generally, `AT+IPR` should be used as a standalone command. If nevertheless combinations with other commands on the same command line cannot be avoided, there are several constraints to be considered:
  - Avoid combinations with the AT commands listed in Section 1.4.2, [Combining AT commands on the same command line](#).
  - Take into account, that a pause of 100ms is required between the response to the last command (e.g. OK) and the next command.
  - When you enter `AT+IPR=0`, autobauding will be activated after the response to the last command is received.
  - When local echo is active (`ATE1`) and you enter `AT+IPR=x` with other commands you may encounter the following problem: if switching to the new bit rate takes effect while a response is being transmitted, the last bytes may be sent with the new bit rate and thus, not properly transmitted. The following commands will be correctly sent at the new bit rate.
- In order to account for greater amounts of data it is recommended to choose a minimum bit rate of 2400 bps. If the ME shall be operated in Multiplex mode we suggest a minimum bit rate of 4800bps.
- In multiplex mode write command is not supported.
- A selected bit rate takes effect after the write commands returns OK.

## 4.10.1 Autobauding

To take advantage of autobaud mode specific attention must be paid to the following requirements:

- Synchronization between TE and TA  
Ensure that TE and TA are correctly synchronized and the bit rate used by the TE is detected by the TA. To allow the bit rate to be synchronized simply use an "AT" or "at" string. This is necessary
  - after you have activated autobauding
  - when you start up the GSM engine while autobauding is enabled. It is recommended to wait 3 to 5 seconds before sending the first AT character. Otherwise undefined characters might be returned.If you want to use autobauding and autoanswer at the same time, you can easily enable the TE-TA synchronization, when you activate autobauding first and then configure the autoanswer mode (`ATS0 ≠ 0`).
- Restrictions on autobauding operation
  - The serial interface shall be used with 8 data bits, no parity and 1 stop bit (factory setting), e.g. 2 stop bits are not supported for autobaud mode.
  - The command `A/` cannot be used.
  - Only the strings "AT" or "at" can be detected (neither "At" nor "aT").
  - URCs that may be issued before the ME detects a new bit rate (by receiving the first AT character) will be sent at the previously detected bit rate or, after ME restart, at 57600 bps.
  - It is not recommended to switch to autobauding from a bit rate that cannot be detected by the autobaud mechanism (e.g. 300 bps). Responses to `AT+IPR=0` and any commands on the same line might be corrupted.

- TC35i Terminal version: autobauding should not be used at bitrates over 115200bps.
- When autobauding is switched on:
  - + only data length, parity and baud rate are automatically detected
  - + if using 1 stop bit, `AT+ICF=1` should not be used, because it uses 2 stop bits
  - + if using 2 stop bits, no combination of `AT+ICF` should be used, which uses 1 stop bit
- Autobauding and bit rate after restart  
The most recently detected bit rate is stored when the ME is powered down (with `AT^SMSO`). Therefore, each time the module is restarted the correct bit rate must be found as described above. Unless the bit rate is determined, the following constraints apply:
  - An incoming CSD call cannot be accepted. This must be taken into account when autobauding and autoanswer mode (`ATS0 ≠ 0`) are enabled at the same time, especially if SIM PIN1 authentication is done automatically and the setting `ATS0 ≠ 0` is stored to the user profile with `AT+W`.
  - Until the bit rate is found, URCs generated after restart will be output at 57600 bps. This applies only to user defined URCs, such as "+CREG", "CCWA", "^SCKS" etc. The URCs "^SYSSTART", "^SYSSTART CHARGE-ONLY MODE" and "^SYSSTART ALARM MODE" will not be indicated when autobauding is enabled.

Note: To avoid any problems caused by undetermined bit rates in the direction from TA to TE we strongly recommend to configure a fixed bit rate rather than autobauding.

- Autobauding and multiplex mode  
If autobauding is active you cannot switch to multiplex mode (see `AT+CMUX`).

## 4.11 AT+CMUX Enter multiplex mode

Multiplex mode according to the ETSI TS 101 669 and GSM 07.10 enables one physical serial asynchronous interface to be partitioned into three virtual channels. This allows you to take advantage of up to 3 simultaneous sessions running on the serial interface. For example, you can send or receive data or make a call on the first channel, while the other two channels are free to control the module with AT commands.

The TC35i module incorporates an internal multiplexer and thus integrates all the functions needed to implement full-featured multiplex solutions. For the application on top, customers have the flexibility to create their own multiplex programs conforming to the multiplexer protocol. To help system integrators save the time and expense of designing multiplexer applications, Cinterion Wireless Modules GmbH offers WinMUX2k, a ready-to-use multiplex driver for Windows 2000 and Windows XP. Another approach is to develop customized solutions based on the sources of the WinMux2k driver.

Refer to [5] which provides a detailed description of the multiplex architecture and step-by-step instructions of how to install and configure the multiplex mode. The WinMUX2k driver and its source files can be supplied on request. Please contact your local distributor to obtain the latest installation software and user's guide.

### Syntax

<p>Test Command</p> <p>AT+CMUX=?</p> <p>Response(s)</p> <p>+CMUX: (list of supported &lt;mode&gt;s)</p> <p>OK</p>																	
<p>Read Command</p> <p>AT+CMUX?</p> <p>Response(s)</p> <p>+CMUX: &lt;mode&gt;</p> <p>OK</p> <p>ERROR</p> <p>+CME ERROR: &lt;err&gt;</p>																	
<p>Write Command</p> <p>AT+CMUX=&lt;mode&gt;</p> <p>Response(s)</p> <p>OK</p> <p>ERROR</p> <p>+CME ERROR: &lt;err&gt;</p>																	
<p>Reference(s)</p> <p>GSM 07.07, GSM 07.10</p>	<table border="1"> <tr> <td>PIN</td> <td>ASC0</td> <td>MUX1</td> <td>MUX2</td> <td>MUX3</td> <td>Charge</td> <td></td> <td>Last</td> </tr> <tr> <td><input type="radio"/></td> <td><input checked="" type="radio"/></td> <td><input type="radio"/></td> <td><input type="radio"/></td> <td><input type="radio"/></td> <td><input type="radio"/></td> <td><input type="radio"/></td> <td><input checked="" type="radio"/></td> </tr> </table>	PIN	ASC0	MUX1	MUX2	MUX3	Charge		Last	<input type="radio"/>	<input checked="" type="radio"/>	<input type="radio"/>	<input type="radio"/>	<input type="radio"/>	<input type="radio"/>	<input type="radio"/>	<input checked="" type="radio"/>
PIN	ASC0	MUX1	MUX2	MUX3	Charge		Last										
<input type="radio"/>	<input checked="" type="radio"/>	<input type="radio"/>	<input type="radio"/>	<input type="radio"/>	<input type="radio"/>	<input type="radio"/>	<input checked="" type="radio"/>										

### Parameter Description

<mode> <sup>(num)</sup>
Multiplexer transparency mechanism
0                                      Basic option
<subset> <sup>(num)</sup>
Subparameters defined in GSM07.07 are adjusted for control and logical channels as follows
0                                      UIH frames used only (control channel)

## Notes

- The write command is used to enter the multiplex mode. The setup of the logical channels is initiated by the TE, i.e. the TE acts as initiator. This means that the TE shall ensure that logical channels are established before any further actions on the channels can be started.
- There is a timeout of five seconds, if the multiplexer protocol is enabled and no multiplexer control channel is established. The GSM engine returns to AT command mode.
- The parameter maximum frame size (N1) of [AT+CMUX](#) in GSM 07.10 is fixed to 98 bytes and can not be changed. All other parameters are not available.
- Multiplexer mode requires character framing to be set to 8 bits, no parity and 1 stop bit. The setting can be made using ([AT+ICF=3](#)).

### 4.11.1 Restrictions on Multiplex mode

In multiplex mode, CSD and fax calls can only be set up on logical channel 1. Due to this restriction, AT commands have a different behavior on channels 2+3 compared to channel 1. Several commands are not available, others return different responses. This section summarizes the concerned commands. For general rules and restrictions to be considered in Multiplex mode please refer to [\[5\]](#).

**Table 4.1:** Availability of AT Commands on Virtual Channels

Command	Behavior on channel 1	Behavior on channel 2+3
+++	not usable, but see note <sup>2)</sup>	not usable, but see note <sup>2)</sup>
<a href="#">AT+CBST</a>	as described	not usable
<a href="#">AT+CRLP</a>	as described	not usable
AT+F... (Fax commands)	as described	not usable
<a href="#">AT&amp;S</a>	as described	not usable
<a href="#">ATA</a>	as described	no Data Calls
<a href="#">ATD</a>	as described	no Data Calls
<a href="#">ATDI</a>	as described	not usable
<a href="#">ATL</a>	as described	not usable
<a href="#">ATM</a>	as described	not usable
<a href="#">ATO</a>	as described	not usable
<a href="#">ATS6</a> <sup>1)</sup>	as described	not usable
<a href="#">ATS7</a> <sup>1)</sup>	as described	not usable
<a href="#">ATS8</a> <sup>1)</sup>	as described	not usable
<a href="#">ATS10</a> <sup>1)</sup>	as described	not usable
<a href="#">ATS18</a> <sup>1)</sup>	as described	not usable
<a href="#">AT\V</a>	as described	not usable

1) The ME supports the registers S0 - S29. You can change S0,S3,S4,S5,S6,S7,S8,S10 and S18 using the related ATSn commands (see starting from [ATS0](#)). The other registers are read-only and for internal use only!

2) The applicability of the +++ escape sequence depends on the customer's external application based on the Multiplexer Protocol. Recommendations for implementing an appropriate modem status command (MSC) are provided in [\[5\]](#), Section "Escape Sequence".

**Table 4.2:** Summary of AT commands with Different Behavior in Multiplex Mode

Command	Description
<a href="#">AT\Q</a>	It is recommended to use hardware flow control ( <a href="#">AT\Q3</a> ). XON/XOFF flow control ( <a href="#">AT\Q1</a> ) is not supported in Multiplex mode. See note regarding <a href="#">AT\Qn</a> settings stored with <a href="#">AT&amp;W</a> if Multiplex mode is active.
<a href="#">AT&amp;V</a>	Different default configurations on channels 1, 2 and 3.
<a href="#">AT&amp;W</a>	Different user profiles can be stored on each channel.
<a href="#">AT+IPR</a>	Before you start Multiplex mode, it is recommended to set the ME to 57600 bps (minimum should be 4800 bps). In Multiplex mode, the write command <a href="#">AT+IPR=&lt;rate&gt;</a> cannot be used.
<a href="#">AT+IPR=0</a>	Multiplex mode cannot be activated while autobauding is enabled.
<a href="#">AT+CALA</a>	On each channel an individual <a href="#">&lt;text&gt;</a> message can be stored. but only one time setting applies to all channels. This means an alarm <a href="#">&lt;time&gt;</a> set on one of the channels overwrites the time setting on all remaining channels. Therefore, the total number of alarm events returned by the read command <a href="#">AT+CALA?</a> will always be <a href="#">&lt;n&gt;</a> =0, no matter whether individual text messages are stored. When the alarm is timed out and executed the ME sends the URC only on the channel where the most recent alarm setting was made. The alarm time will be reset to "00/01/01,00:00:00" on all channels.
<a href="#">AT+CMEE</a>	Presentation mode can be separately configured for each channel.
<a href="#">AT+CNMA</a>	If Multiplex mode is activated the +CNMI parameter will be set to zero on all channels, if one channel fails to acknowledge an incoming message within the required time.
<a href="#">AT+CNMI</a>	Phase 2+ parameters can only be used on one channel. The parameter for <a href="#">&lt;mt&gt;</a> and <a href="#">&lt;ds&gt;</a> on the other channels have to be set to zero. If either a SM or a Status Report is not acknowledged, all +CNMI parameter will be set to zero on all channels.
<a href="#">AT+CFUN</a>	If the ME is in Multiplexer mode, it is not recommended to activate SLEEP mode with <a href="#">AT+CFUN=&lt;fun&gt;</a> . The best approach to properly control SLEEP mode in this case is to issue the PSC messages described in [5], Section "Power saving control (PSC)".
<a href="#">AT+CPMS</a>	Parameter <a href="#">&lt;mem3&gt;</a> will be the same on all instances, but the settings of <a href="#">&lt;mem1&gt;</a> and <a href="#">&lt;mem2&gt;</a> may vary on each instance.
<a href="#">AT^SSDA</a>	If one instance is set to <a href="#">&lt;da&gt;</a> =1 and <a href="#">&lt;mt&gt;</a> =1, then all other instances must be configured for <a href="#">&lt;mt&gt;</a> =0.

## 4.12 AT^STPB Transmit Parity Bit (for 7E1 and 7O1 only)

This command is intended only for use with 7E1 and 7O1. In addition to the 7E1 or 7O1 settings made with [AT+ICF](#) the command [AT^STPB](#) specifies whether or not to transmit the parity bit over the air.

### Syntax

<p>Test Command</p> <pre>AT^STPB=?</pre> <p>Response(s)</p> <pre>^STPB: (list of supported &lt;n&gt;s) OK</pre>																	
<p>Read Command</p> <pre>AT^STPB?</pre> <p>Response(s)</p> <pre>^STPB: &lt;n&gt; OK</pre>																	
<p>Write Command</p> <pre>AT^STPB=&lt;n&gt;</pre> <p>Response(s)</p> <pre>OK ERROR +CME ERROR: unknown</pre>																	
<p>Reference(s)</p> <pre>--</pre>	<table border="1"> <tr> <td>PIN</td> <td>ASC0</td> <td>MUX1</td> <td>MUX2</td> <td>MUX3</td> <td>Charge</td> <td></td> <td>Last</td> </tr> <tr> <td><input type="radio"/></td> <td><input checked="" type="radio"/></td> <td><input type="radio"/></td> <td><input type="radio"/></td> <td><input type="radio"/></td> <td><input type="radio"/></td> <td><input type="radio"/></td> <td><input type="radio"/></td> </tr> </table>	PIN	ASC0	MUX1	MUX2	MUX3	Charge		Last	<input type="radio"/>	<input checked="" type="radio"/>	<input type="radio"/>	<input type="radio"/>	<input type="radio"/>	<input type="radio"/>	<input type="radio"/>	<input type="radio"/>
PIN	ASC0	MUX1	MUX2	MUX3	Charge		Last										
<input type="radio"/>	<input checked="" type="radio"/>	<input type="radio"/>	<input type="radio"/>	<input type="radio"/>	<input type="radio"/>	<input type="radio"/>	<input type="radio"/>										

### Command Description

The test command returns the supported values of the parameter [<n>](#).

The read command returns the current value of the parameter [<n>](#).

The write command can be used to control the handling of the parity bit. If command fails, "+CME ERROR: unknown" will be returned.

### Parameter Description

<a href="#">&lt;n&gt;</a> <sup>(num)&amp;W</sup>	
0(&F)	The parity bit will not be transmitted over the air and will be replaced with 0. This mode is the default setting if 7E1 or 7O1 is activated with <a href="#">AT+ICF</a> .
1	In a data connection 8 bits will be transmitted, including the parity bit, i.e. the parity bit will be properly transmitted over the air. The setting shall be used if problems are encountered when TC35i is running in the default 7E1 or 7O1 mode enabled with <a href="#">AT+ICF</a> . In this case, <a href="#">AT^STPB=1</a> shall be set in addition to the 7E1 or 7O1 settings selected with <a href="#">AT+ICF</a> .

### Note

- Command is usable if multiplexer is enabled but setting is ignored.



## 5. Security Commands

The AT Commands described in this chapter allow the external application to determine various security related settings.

### 5.1 AT+CPIN PIN Authentication

[AT+CPIN](#) controls network authentication of the TC35i.

The read command returns an alphanumeric string indicating whether or not network authentication is required.

The write command allows the TC35i to store the entered password. This may be for example the SIM PIN1 to register to the GSM network, or the SIM PUK1 to replace a disabled SIM PIN1 with a new one, or the PH-SIM PIN if the client has taken precautions for preventing damage in the event of loss or theft etc.

If no PIN1 request is pending (for example if PIN1 authentication has been done and the same PIN1 is entered again) TC35i responds "+CME ERROR: operation not allowed"; no further action is required.

Each time a password is entered with [AT+CPIN](#) the module starts reading data from the SIM. The duration of reading varies with the SIM card. This may cause a delay of several seconds before all commands which need access to SIM data are effective. See Section 18.1, [Restricted access to SIM data after SIM PIN authentication](#) for further detail.

#### Syntax

Test Command	
AT+CPIN=?	
Response(s)	
OK	
Read Command	
AT+CPIN?	
Response(s)	
+CPIN: <code>	
OK	
ERROR	
+CME ERROR: <err>	
Write Command	
AT+CPIN=<pin>[, <new pin>]	
Response(s)	
OK	
ERROR	
+CME ERROR: <err>	
Reference(s)	
GSM 07.07	
	PIN ASC0 MUX1 MUX2 MUX3 Charge  Last
	<input type="radio"/> <input checked="" type="radio"/> <input checked="" type="radio"/> <input checked="" type="radio"/> <input checked="" type="radio"/> <input checked="" type="radio"/> <input type="radio"/> <input type="radio"/> <input type="radio"/>

**Parameter Description**

`<pin>`<sup>(str)</sup>

Password (string type), usually SIM PIN1.

If the requested password was a PUK, such as SIM PUK1 or PH-FSIM PUK or another password, then `<pin>` must be followed by `<new pin>`.

`<new pin>`<sup>(text)</sup>

If the requested code was a PUK: specify a new password or restore the former disabled password. See Section 5.1.1, [What to do if PIN or password authentication fails?](#) for more information about when you may need to enter the PUK.

`<code>`<sup>(text)</sup>

SIM PIN authentication

READY	PIN has already been entered. No further entry needed.
SIM PIN	ME is waiting for SIM PIN1.
SIM PUK	ME is waiting for SIM PUK1 if PIN1 was disabled after three failed attempts to enter PIN1.
SIM PIN2	ME is waiting for PIN2. This is only applicable when an attempt to access a PIN2 related feature was acknowledged with +CME ERROR: 17 ("SIM PIN2 required"), for example when the client attempts to edit the FD phonebook). In this case the read command <code>AT+CPIN?</code> also prompts for SIM PIN2. Normally, the <code>AT+CPIN2</code> command is intended for SIM PIN2.
SIM PUK2	ME is waiting for PUK2 to unblock a disabled PIN2. As above, this is only necessary when the preceding command was acknowledged with +CME ERROR: 18 ("SIM PUK2 required") and only if the read command <code>AT+CPIN?</code> also prompts for SIM PUK2. Normally, the <code>AT+CPIN2</code> command is intended for SIM PUK2.

Phone security locks set by client or factory

PH-SIM PIN	ME is waiting for phone-to-SIM card password if "PS" lock is active and the client inserts other SIM card than the one used for the lock. ("PS" lock is also referred to as phone or antitheft lock).
PH-SIM PUK	ME is waiting for Master Phone Code, if the above "PS" lock password was incorrectly entered three times.
PH-FSIM PIN	ME is waiting for phone-to-very-first-SIM card. Necessary when "PF" lock was set. When powered up the first time, ME locks itself to the first SIM card put into the card holder. As a result, operation of the mobile is restricted to this one SIM card (unless the PH-FSIM PUK is used as described below).
PH-FSIM PUK	ME is waiting for phone-to-very-first-SIM card unblocking password to be given. Necessary when "PF" lock is active and other than first SIM card is inserted.
PH-NET PUK	ME is waiting for network personalisation unblocking password
PH-NS PIN	ME is waiting for network subset personalisation password
PH-NS PUK	ME is waiting for network subset unblocking password
PH-SP PIN	ME is waiting for service provider personalisation password
PH-SP PUK	ME is waiting for service provider personalisation unblocking password
PH-C PIN	ME is waiting for corporate personalisation password
PH-C PUK	ME is waiting for corporate personalisation un-blocking password

## Notes

- Successful PIN authentication only confirms that the entered PIN was recognized and correct. The output of the result code OK does not necessarily imply that the mobile is registered to the desired network. Typical example: PIN was entered and accepted with OK, but the ME fails to register to the network. This may be due to missing network coverage, denied network access with currently used SIM card, no valid roaming agreement between home network and currently available operators etc. TC35i offers various options to verify the present status of network registration: For example, the [AT+COPS](#) command indicates the currently used network. With [AT+CREG](#) you can also check the current status and activate an unsolicited result code which appears whenever the status of the network registration changes (e.g. when the ME is powered up, or when the network cell changes).
- `<pin>` and `<new pin>` can also be entered in quotation marks (e.g. "1234").
- To check the number of remaining attempts to enter the passwords use the [AT^SPIC](#) command.
- See [AT+CPWD](#) and [AT^SPWD](#) for information on passwords.
- See [AT+CLCK](#) and [AT^SLCK](#) for information on lock types.

### 5.1.1 What to do if PIN or password authentication fails?

#### PIN1 / PUK1:

After three failures to enter PIN 1, the SIM card is blocked (except for emergency calls). +CME ERROR: 12 will prompt the client to unblock the SIM card by entering the associated PUK (= PIN Unblocking Key / Personal Unblocking Key). After ten failed attempts to enter the PUK, the SIM card will be invalidated and no longer operable. In such a case, the card needs to be replaced. PIN1 consists of 4 to 8 digits, PUK1 is an 8-digit code only. To unblock a disabled PIN1 you have two options:

- You can enter [AT+CPIN=PUK1,new PIN1](#).
- You can use the [ATD](#) command followed by the GSM code `**05*PUK*newPIN*newPIN#;`.

#### PIN2 / PUK2:

PIN2 prevents unauthorized access to the features listed in [AT+CPIN2](#). The handling of PIN2 varies with the provider. PIN2 may either be a specific code supplied along with an associated PUK2, or a default code such as 0000. In either case, the client is advised to replace it with an individual code. Incorrect input of PUK2 will permanently block the additional features subject to PIN2 authentication, but usually has no effect on PIN1. PIN2 consists of 4 digits, PUK2 is an 8-digit code only.

To unblock a disabled PIN2 you have two options:

- You can enter [AT+CPIN2=PUK2,new PIN2](#).
- You can use the [ATD](#) command followed by the GSM code `**052*PUK2*newPIN2*newPIN2#;`.

#### Phone lock:

If the mobile was locked to a specific SIM card (= "PS" lock or phone lock), the PUK that came with the SIM card cannot be used to remove the lock. After three failed attempts to enter the correct password, ME returns +CPIN: PH-SIM PUK (= response to read command [AT+CPIN?](#)), i.e. it is now waiting for the Master Phone Code. This is an 8-digit device code associated to the IMEI number of the mobile which can only be obtained from the manufacturer or provider. When needed, contact Cinterion Wireless Modules GmbH and request the Master Phone Code of the specific module.

There are two ways to enter the Master Phone code:

- You can enter [AT+CPIN=Master Phone Code](#)
- You can use the [ATD](#) command followed by the GSM code `*#0003*Master Phone Code#;`.

Usually, the Master Phone Code will be supplied by mail or e-mail. If the received number is enclosed in the \*# codes typically used for the [ATD](#) option, it is important to crop the preceding \*#0003\* characters and the appended #.

Example: You may be given the string `*#0003*12345678#`. When prompted for the PH-SIM PUK simply enter 12345678.

If incorrectly input, the Master Phone Code is governed by a specific timing algorithm: (n-1)\*256 seconds (see table below). The timing should be considered by system integrators when designing an individual MMI.

Number of failed attempts	Time to wait before next input is allowed
1st failed attempt	No time to wait
2nd failed attempt	4 seconds
3rd failed attempt	3 * 256 seconds
4th failed attempt	4 * 256 seconds
5th failed attempt	5 * 256 seconds
6th failed attempt and so forth	6 * 256 seconds and so forth

#### SIM locks:

These are factory set locks, such as "PF", "PN", "PU", "PP", "PC". An 8-digit unlocking code is required to operate the mobile with a different SIM card, or to lift the lock. The code can only be obtained from the provider.

Failure to enter the password is subject to the same timing algorithm as the Master Phone Code (see Table above).

#### Call barring:

Supported modes are "AO", "OI", "OX", "AI", "IR", "AB", "AG", "AC". If the call barring password is entered incorrectly three times, the client will need to contact the service provider to obtain a new one.

#### Related sections:

"+CME ERROR: <err>" values are specified at Section [2.12.1, CME/CMS Error Code Overview](#). For further instructions and examples see [AT+CLCK](#), [AT^SLCK](#), [AT+CPWD](#) and [AT^SPWD](#).

For a complete list of Star-Hash codes please refer Section [18.2, Star-Hash \(\\*#\) Network Commands](#).

## 5.2 AT+CPIN2 PIN2 Authentication

[AT+CPIN2](#) controls network authentication of the TC35i.

The read command returns an alphanumeric string indicating whether or not network authentication is required. The write command allows the TC35i to store the entered password. This may be for example the SIM PIN2 to benefit from the features listed below, or the SIM PUK2 to replace a disabled PIN2 with a new one. Note that PIN2 can only be entered if PIN1 authentication was done.

If the TC35i is requesting SIM PUK2, use `<pin>` to enter the PUK2, followed by `<new pin>` to specify the new PIN2.

### Syntax

<p>Test Command</p> <pre>AT+CPIN2=?</pre> <p>Response(s)</p> <pre>OK</pre>																	
<p>Read Command</p> <pre>AT+CPIN2?</pre> <p>Response(s)</p> <pre>+CPIN2: &lt;code&gt; OK ERROR +CME ERROR: &lt;err&gt;</pre>																	
<p>Write Command</p> <pre>AT+CPIN2=&lt;pin&gt;[, &lt;new pin&gt;]</pre> <p>Response(s)</p> <pre>OK ERROR +CME ERROR: &lt;err&gt;</pre>																	
<p>Reference(s)</p> <pre>GSM 07.07</pre>	<table border="1"> <thead> <tr> <th>PIN</th> <th>ASC0</th> <th>MUX1</th> <th>MUX2</th> <th>MUX3</th> <th>Charge</th> <th></th> <th>Last</th> </tr> </thead> <tbody> <tr> <td><input checked="" type="radio"/></td> <td><input checked="" type="radio"/></td> <td><input checked="" type="radio"/></td> <td><input checked="" type="radio"/></td> <td><input checked="" type="radio"/></td> <td><input type="radio"/></td> <td><input type="radio"/></td> <td><input type="radio"/></td> </tr> </tbody> </table>	PIN	ASC0	MUX1	MUX2	MUX3	Charge		Last	<input checked="" type="radio"/>	<input checked="" type="radio"/>	<input checked="" type="radio"/>	<input checked="" type="radio"/>	<input checked="" type="radio"/>	<input type="radio"/>	<input type="radio"/>	<input type="radio"/>
PIN	ASC0	MUX1	MUX2	MUX3	Charge		Last										
<input checked="" type="radio"/>	<input checked="" type="radio"/>	<input checked="" type="radio"/>	<input checked="" type="radio"/>	<input checked="" type="radio"/>	<input type="radio"/>	<input type="radio"/>	<input type="radio"/>										

### Parameter Description

<code>&lt;pin&gt;</code> <sup>(str)</sup>	<p>Password (string type), usually SIM PIN2 or, if requested, SIM PUK2.</p>						
<code>&lt;new pin&gt;</code> <sup>(str)</sup>	<p>If the requested code was SIM PUK2: new password (PIN2). See Section 5.1.1, <a href="#">What to do if PIN or password authentication fails?</a> for more information about when you may need to enter the PUK.</p>						
<code>&lt;code&gt;</code> <sup>(text)</sup>	<table border="1"> <tr> <td>READY</td> <td>ME is not pending for any password.</td> </tr> <tr> <td>SIM PIN2</td> <td>ME is waiting for SIM PIN2. This <code>&lt;code&gt;</code> is returned only when PIN2 authentication has not yet been done or has failed ("+CME ERROR:17").</td> </tr> <tr> <td>SIM PUK2</td> <td>ME is waiting for SIM PUK2. This <code>&lt;code&gt;</code> is returned only when PIN2 authentication has failed and ME is pending for SIM PUK2 (i.e. "+CME ERROR:18").</td> </tr> </table>	READY	ME is not pending for any password.	SIM PIN2	ME is waiting for SIM PIN2. This <code>&lt;code&gt;</code> is returned only when PIN2 authentication has not yet been done or has failed ("+CME ERROR:17").	SIM PUK2	ME is waiting for SIM PUK2. This <code>&lt;code&gt;</code> is returned only when PIN2 authentication has failed and ME is pending for SIM PUK2 (i.e. "+CME ERROR:18").
READY	ME is not pending for any password.						
SIM PIN2	ME is waiting for SIM PIN2. This <code>&lt;code&gt;</code> is returned only when PIN2 authentication has not yet been done or has failed ("+CME ERROR:17").						
SIM PUK2	ME is waiting for SIM PUK2. This <code>&lt;code&gt;</code> is returned only when PIN2 authentication has failed and ME is pending for SIM PUK2 (i.e. "+CME ERROR:18").						

## Note

- Functions accessible only after PIN2 authentication:  
[AT+CACM](#): Accumulated call meter (ACM) reset or query  
[AT+CAMM](#): Accumulated call meter maximum (ACMmax) set or query  
[AT+CLCK](#): Facility lock to "FD" (Fixed dialing phonebook)  
[AT^SLCK](#): Facility lock to "FD" (Fixed dialing phonebook)  
[AT+CPWD](#): Change "P2"password  
[AT^SPWD](#): Change "P2"password  
[AT+CPUC](#): Price per unit and currency table  
[AT+CPIN2](#): Enter SIM PIN2 or SIM PUK2 if requested.

For example, SIM PIN2 will be needed when you attempt to edit the "FD" phonebook and ME returns "+CME Error 17" or "+CPIN: SIM PIN2".

Once the required `<pin>` has been entered correctly, PIN2 authentication code changes to READY. After 300s, a repetition of the authentication process is required (PIN2 authentication code changes from READY to SIM PIN2).

## Examples

### EXAMPLE 1

#### Change PIN2

```
AT+CPWD="P2","0000","8888"  
OK
```

(where "0000" = old PIN2 and "8888" = new PIN2)

### EXAMPLE 2

#### Unblock a disabled PIN2

```
AT+CPIN2?  
+CPIN2: SIM PUK2  
OK  
AT+CPIN2=12345678,8888
```

PIN2 has been disabled, PUK2 must be entered to define a new PIN2 where "12345678" is the PUK2, and "8888" the new PIN2.

### EXAMPLE 3

#### Write into "FD" phonebook

```
AT+CPBS="FD"  
OK  
AT+CPBW=2,"+493012345678",145,"Charly"  
+CME ERROR 17  
AT+CPIN2=8888  
OK  
AT+CPBW=2,"+493012345678",145,"Charly"  
OK
```

access denied due to missing PIN2 authentication

## 5.3 AT^SPIC Display PIN counter

The [AT^SPIC](#) command can be used to find out whether the ME is waiting for a password and, if so, how many attempts are left to enter the password.

The execute command returns the number of attempts still available for entering the currently required password, for example the PIN, PUK, PH-SIM PUK etc.

To check whether or not you need to enter a password use the read commands [AT+CPIN?](#), [AT+CPIN2?](#). If the response to [AT+CPIN?](#) is "READY" the counter of the execute command [AT^SPIC](#) relates to PIN2. See [last example](#). If the responses to [AT+CPIN?](#) and [AT+CPIN2?](#) both read "READY", no password is currently required, and the referrer of the execute command [AT^SPIC](#) is explicitly undefined.

### Syntax

Test Command	AT^SPIC=?																
Response(s)	OK																
Exec Command	AT^SPIC																
Response(s)	^SPIC: <counter> OK																
Reference(s)	<table border="1"> <thead> <tr> <th>PIN</th> <th>ASC0</th> <th>MUX1</th> <th>MUX2</th> <th>MUX3</th> <th>Charge</th> <th></th> <th>Last</th> </tr> </thead> <tbody> <tr> <td><input type="radio"/></td> <td><input checked="" type="radio"/></td> <td><input checked="" type="radio"/></td> <td><input checked="" type="radio"/></td> <td><input checked="" type="radio"/></td> <td><input type="radio"/></td> <td><input type="radio"/></td> <td><input type="radio"/></td> </tr> </tbody> </table>	PIN	ASC0	MUX1	MUX2	MUX3	Charge		Last	<input type="radio"/>	<input checked="" type="radio"/>	<input checked="" type="radio"/>	<input checked="" type="radio"/>	<input checked="" type="radio"/>	<input type="radio"/>	<input type="radio"/>	<input type="radio"/>
PIN	ASC0	MUX1	MUX2	MUX3	Charge		Last										
<input type="radio"/>	<input checked="" type="radio"/>	<input checked="" type="radio"/>	<input checked="" type="radio"/>	<input checked="" type="radio"/>	<input type="radio"/>	<input type="radio"/>	<input type="radio"/>										

### Parameter Description

<counter><sup>(num)</sup>

Number of attempts left to enter the currently required password. This number will be counted down after each failure.

### Notes

- Whenever the required password changes, <counter> changes to reflect that change. Please refer to the examples below.
- For passwords associated to the phone lock ("PS" lock set by user or factory) or other factory set locks, such as "PF", "PN", "PU", 'PP", "PC" the number of attempts is subject to a timing algorithm explained in [AT+CPIN](#). If these passwords are incorrectly entered the counter first returns 3, 2 and 1 remaining attempt(s), but then gives the total number of attempts which amounts to 63 (see example below).
- See also Chapters [AT+CLCK](#), [AT+CPIN](#), [AT+CPIN2](#), [AT+CPWD](#), [AT^SLCK](#) for further information on locks and passwords.

### Examples

#### EXAMPLE 1

The user fails to provide a correct SIM PIN three times. The counter decreases each time. After the counter reaches zero, the SIM PUK is required. After each failure to enter a correct SIM PUK, the counter decreases.

```
at+cpin?
+CPIN: SIM PIN
OK
at^spic
^SPIC: 3
```

Currently required password is PIN1.

```
OK                                     3 attempts left.
at+cpin=9999
+CME ERROR: incorrect password
at^spic
^SPIC: 2                               2 attempts left.
OK
at+cpin=9999
+CME ERROR: incorrect password
OK
at^spic
^SPIC: 1                               1 attempt left.
OK
at+cpin=9999
+CME ERROR: incorrect password
at+cpin?
+CPIN: SIM PUK
OK                                     Now required password is PUK 1.
at^spic
^SPIC: 10
OK                                     10 attempts left for PUK 1.
at+cpin=01234567,1234
+CME ERROR: incorrect password
at^spic
^SPIC: 9
OK                                     9 attempts left for PUK 1.
```

EXAMPLE 2

Though a mobile is locked to a specific SIM card (phone lock), the user attempts to operate it with another SIM card. The user correctly enters the SIM PIN of the SIM card currently inserted, but then fails to give the "PS" lock password (PH-SIM PUK):

```
at+cpin=9999
OK
at+cpin?
+CPIN: PH-SIM PIN                     ME is waiting for the phone lock password.
OK
at^spic
^SPIC: 3                               3 attempts left.
OK
at+cpin=4711
+CME ERROR: incorrect password
at^spic?
^SPIC: 2                               2 attempts left.
OK
at+cpin=4712
+CME ERROR: incorrect password
at^spic
^SPIC: 1                               1 attempt left.
OK
at+cpin=4713
+CME ERROR: incorrect password
at^spic
^SPIC: 63
OK
at+cpin=4714
+CME ERROR: incorrect password
at^spic
```



```
^SPIC: 63  
OK
```

EXAMPLE 3

This example shows that after successful SIM PIN1 authentication the counter of the `AT^SPIC` execute command refers to SIM PIN2, i.e. it does not reflect the status of SIM PIN1. This may be a problem if the user enters a wrong PIN1 and is not aware that the number of attempts left to enter SIM PIN1 is counted down.

```
+CREG: 0  
at+cpin=1234  
OK  
+CREG: 2
```

The mobile is properly registered to the network.

```
+CREG: 1  
at+cpin?  
+CPIN: READY
```

The `AT+CPIN?` read command confirms that SIM PIN1 authentication was successful.

```
at^spic  
^SPIC: 3
```

As SIM PIN1 authentication was successful, the counter relates to SIM PIN2 and correctly indicates that the user has 3 attempts to enter SIM PIN2.

```
OK  
at+clck="SC",0,456789  
CME ERROR: incorrect password  
at^spic  
^SPIC: 3
```

First attempt to enter a wrong SIM PIN1.

```
at+clck="SC",0,456789  
CME ERROR: incorrect password  
at^spic  
^SPIC: 3
```

SIM PIN1 authentication is still valid, and the counter relates to SIM PIN2.

Second attempt to enter a wrong SIM PIN1.

```
at+clck="SC",0,456789  
CME ERROR: incorrect password
```

SIM PIN1 authentication is still valid, and the counter relates to SIM PIN2.

Third attempt to enter a wrong SIM PIN1.

```
+CREG: 0  
at^spic  
^SPIC: 10
```

SIM PIN1 authentication is no longer valid.

This time, after the SIM PIN1 code has been disabled, the counter indicates the status of SIM PIN1 and notifies that 10 attempts are left to enter the SIM PUK.

## 5.4 AT+CLCK Facility lock

AT+CLCK can be used to lock, unlock or interrogate a network or ME <facility>. The command can be aborted when network facilities are being set or interrogated.

### Syntax

<p>Test Command</p> <pre>AT+CLCK=?</pre> <p>Response(s)</p> <pre>+CLCK: list of supported &lt;facility&gt;s OK</pre>	<p>Write Command</p> <pre>AT+CLCK=&lt;facility&gt;, &lt;mode&gt;[, &lt;password&gt;][, &lt;class&gt;]</pre> <p>Response(s)</p> <pre>if &lt;mode&gt; is not equal 2 and command successful: OK if &lt;mode&gt;= 2 and command successful: +CLCK: &lt;status&gt;[, &lt;class&gt;] [+CLCK: &lt;status&gt;[, &lt;class&gt;]] [+CLCK: ...] OK If error is related to ME functionality +CME ERROR</pre>																
<p>Reference(s)</p> <pre>GSM 07.07, GSM 02.04, GSM 02.88, GSM 03.88, GSM 04.88</pre>	<table border="1"> <thead> <tr> <th>PIN</th> <th>ASC0</th> <th>MUX1</th> <th>MUX2</th> <th>MUX3</th> <th>Charge</th> <th></th> <th>Last</th> </tr> </thead> <tbody> <tr> <td><input checked="" type="checkbox"/></td> <td><input checked="" type="checkbox"/></td> <td><input checked="" type="checkbox"/></td> <td><input checked="" type="checkbox"/></td> <td><input checked="" type="checkbox"/></td> <td><input type="checkbox"/></td> <td><input type="checkbox"/></td> <td><input type="checkbox"/></td> </tr> </tbody> </table>	PIN	ASC0	MUX1	MUX2	MUX3	Charge		Last	<input checked="" type="checkbox"/>	<input checked="" type="checkbox"/>	<input checked="" type="checkbox"/>	<input checked="" type="checkbox"/>	<input checked="" type="checkbox"/>	<input type="checkbox"/>	<input type="checkbox"/>	<input type="checkbox"/>
PIN	ASC0	MUX1	MUX2	MUX3	Charge		Last										
<input checked="" type="checkbox"/>	<input checked="" type="checkbox"/>	<input checked="" type="checkbox"/>	<input checked="" type="checkbox"/>	<input checked="" type="checkbox"/>	<input type="checkbox"/>	<input type="checkbox"/>	<input type="checkbox"/>										

### Parameter Description

<b>&lt;facility&gt;</b> <sup>(str)</sup>	
Phone security locks set by client or factory	
Primarily intended for the client to take safety precautions, "SC", "PS" and "FD" can be configured individually. "PS" may also be factory set.	
Parameter <class> is not applicable to security locks.	
See examples below for further details.	
"SC"	SIM (lock SIM cards). SIM requests password upon ME power-up and when this lock command is issued. <password>: SIM PIN1.
"PS"	Phone locked to SIM card. ME requests password when other than current SIM card is inserted. "PS" lock is frequently referred to as "phone lock", or "device lock". Accordingly, the password may be called "phone code" or "device code". The "PS" password is not associated with the PUK of the SIM card. If incorrectly entered three times, the Master Phone Code is required to lift the lock. This is an 8-digit device code associated to the IMEI number of the mobile which can only be obtained from the manufacturer of the module. Once the Master Phone Code has been accepted, the mobile is operational, and the "PS" lock is no longer active. If needed it must be set once again.

**<password>**: User defined password. It is needed before the first use of **<facility>** "PS" and, therefore, must first be specified with **AT+CPWD** or **AT^SPWD**, if it has not been predefined by factory settings. If set by factory (e.g. for a prepaid mobile), the password is supplied by the provider or operator.

"FD"

**SIM fixed dialling memory**: If the mobile is locked to "FD", only the phone numbers stored to the "FD" memory can be dialled. (Capacity of FD phonebook depending on the SIM card).

**<password>**: SIM PIN 2.

If a lock on the SIM fixed dialling memory is active, the following applies:

- **Outgoing voice, data or fax calls** can be made only to numbers stored in "FD" phonebook.  
Result code depends on the type of the call:  
for voice calls, indication is "+CME Error 257: Call barred".  
for data and fax calls, indication is "NO CARRIER".
- **Access to defined Supplementary Services** such as Call barring, Call waiting, Call forwarding, Call hold and Multiparty is possible only if the exact corresponding public MMI \*# code for the desired service is stored in the fixed dialling number phone book, and used with ATD.  
AT commands for supplementary service control are barred while "FD" lock is active.  
Indication is "+CME Error 257: Call barred".
- **Access to Unstructured Supplementary Services ("USSD")** is possible only if the exact desired USSD string is stored in the fixed dialling number phone book, and used with ATD.  
AT commands for USSD are barred while "FD" lock is active.  
Indication is "+CME Error 257: Call barred".
- **SMS** can be sent only to phone numbers which are stored in the "fixed dialling numbers" phonebook "FD".  
Indication is "+CMS Error 302: operation not allowed".

#### Factory defined SIM locks:

Typical examples of factory set SIM locks are prepaid phones or network locks, used to restrict the operation of a mobile to a specific provider or operator. The client should be aware that each of these lock types can only be unlocked if the associated password is available. For example, a mobile can be locked to accept only SIM cards from the respective provider, or even one single SIM card. Once a different SIM card is inserted the ME will prompt the client to enter a specific code. This is not the PUK of the SIM card, but usually an 8-digit code which needs to be requested from the provider.

The locks can only be set by the manufacturer and need to be agreed upon between the parties concerned, e.g. provider, operator, distributor etc. on the one side and the manufacturer on the other side. For details contact your local dealer or Cinterion Wireless Modules GmbH.

Parameter **<class>** is not applicable to SIM locks.

**<password>** and instructions for unlocking must be obtained from the network provider.

"PF"	lock Phone to the very First SIM card
"PN"	Network Personalisation
"PU"	Network subset Personalisation
"PP"	Service Provider Personalisation
"PC"	Corporate Personalisation

#### Supplementary Service Call Barring:

Supplementary Service "Call Barring" allows to specify conditions under which calls will be disallowed by the network.

The availability of the Supplementary Services varies with the network. To benefit from call barring the client will need to subscribe them, though a limited number of call barring types may be included in the basic tariff package.

When you attempt to set a **<facility>** or **<class>** which is not provisioned, not yet subscribed to, or not supported by the module, the setting will not take effect regardless of the response returned. The responses in these

cases vary with the network (for example "OK", "+CMEERROR: Operation not allowed", "+CME ERROR: Operation not supported" etc.). To make sure check the extended error response with [AT+CEER](#) and the lock status with `<mode>=2`.

`<password>`: Network password supplied from the provider or operator. Usually there is one password which applies to all call barring options. For details contact your provider.

"AO"	BAOC (Bar All Outgoing Calls)
"OI"	BOIC (Bar Outgoing International Calls)
"OX"	BOIC-exHC (Bar Outgoing International Calls except to Home Country)
"AI"	BAIC (Bar All Incoming Calls)
"IR"	BIC-Roam (Bar Incoming Calls when Roaming outside the home country)
"AB"	All Barring services (applicable only for <code>&lt;mode&gt;=0</code> )
"AG"	All outGOing barring services (applicable only for <code>&lt;mode&gt;=0</code> )
"AC"	All inCOming barring services (applicable only for <code>&lt;mode&gt;=0</code> )

`<mode>`<sup>(num)</sup>

0	unlock
1	lock
2	query status

`<status>`<sup>(num)</sup>

0	lock is inactive
1	lock is active

`<password>`<sup>(str)</sup>

Password string used to lock and to unlock a `<facility>`. Length and authority for passwords depend on the `<facility>` in question and are therefore listed in the section on parameter `<facility>`. Passwords can be modified with [AT+CPWD](#) or [AT^SPWD](#).

`<class>`<sup>(num)</sup>

Integer or sum of integers each representing a class of information, i.e. a bearer service, telecommunication service or bearer service group as defined in "GSM 02.04".

1	voice
2	class 2 ("data") comprises all those individual data classes between 16 and 128, that are supported both by the network and the MS. This means, a setting made for class 2 applies to all individual data classes (if supported). In addition, you can assign a different setting to a specific class. For example, you can activate Call Forwarding for all data classes, but deactivate it for data class 64, "dedicated packet access".
4	fax
8	SMS
16	data circuit sync
32	data circuit async
64	dedicated packet access
128	dedicated PAD access
1...[7]...255	combination of some of the above classes. For example, the default setting 7 represents the sum of the integers 1, 2 and 4 (voice, data and fax). The value 255 covers all classes. If parameter "class" is omitted, the default value 7 is used.

## Notes

- The **AT+CLCK** command offers the full range of **<class>** parameters according to the GSM specifications. However, when you attempt to use a service option which is not provisioned or not yet subscribed to, the setting will not take effect regardless of the response returned. The responses in these cases vary with the network (for example "OK", "Operation not allowed", "Operation not supported" etc.). To make sure check the extended error response with **AT+CEER** and the lock status with **<mode>=2**.
- The command has been implemented with the full set of **<class>** parameters according to GSM 07.07. For actual applicability of a desired Call barring service to a specific service or service group (a specific **<class>** value) please consult table A.1 of GSM 02.04.
- If an outgoing Fax or Data Call is rejected due to an active "call barring" supplementary service, the call will be terminated with result code NO CARRIER. Under the same conditions, an outgoing Voice call will be terminated with result code NO DIALTONE.
- If an invalid **<password>** is entered several times in succession, a delay incremented after each failed attempt will increase the time to wait before the input of the **<password>** is accepted. To avoid blocking the serial interface the running **AT+CLCK** command is aborted after a short timeout and returns CME ERROR 100 ("unknown"). If then the **AT+CLCK** command is issued once again execution is denied with CME ERROR 256 ("Operation temporary not allowed"). For details regarding the delay see Section 5.1.1, [What to do if PIN or password authentication fails?](#)
- If the user tries to set a lock although it is already active or, the other way round, tries to unlock an inactive lock, the response will be OK, but the **<password>** will not be checked or verified.

## Examples

### EXAMPLE 1

Lock SIM card (**<facility>= "SC"**)

```
AT+CLCK="SC",1,"9999"
```

```
OK
```

The "SC" parameter enables or disables the SIM PIN authentication (PIN 1) when you power up the GSM engine. SIM card locked. As a result, SIM PIN 1 must be entered to enable ME to register to the GSM network.

```
AT+CLCK="SC",0,"9999"
```

```
OK
```

Unlocks SIM card. When powered up, ME registers to the GSM network without requesting SIM PIN1. Note: Depending on the services offered by the provider, this feature is not supported by all SIMcard types. If so, the command returns ERROR when you attempt to unlock the card.

To query the status of the SIM card lock:

```
AT+CLCK="SC",2
```

```
+CLCK: 1
```

```
OK
```

Query the status of SIM card lock. SIM card is locked. SIM PIN1 must be entered to enable ME to register to the GSM network.

EXAMPLE 2

Phone lock (<facility>="PS")

```
AT+CPIN?           Make sure that PIN1 authentication is valid.
OK
```

To lock the ME to the currently inserted SIM card, first specify a password for <facility> "PS":

```
AT+CPWD="PS",,"1234"   If "PS" lock has not been set before: enter new password.
OK
```

Optionally, if "PS" password was defined before, change existing password:

```
AT+CPWD="PS","1234","3333"  To replace existing "PS" password: Enter old and new password.
OK
```

Then, activate the Phone Lock:

```
AT+CLCK="PS",1,"3333"     Locks the mobile to the current SIM card.
OK
```

To operate the mobile with the SIM card for which "PS" lock was activated:

```
AT+CPIN?
+CPIN: SIM PIN
OK
AT+CPIN="9999"
OK           No additional password is required for operation (SIM recognized by
            mobile).
```

To operate the mobile with other SIM card than the one used for the "PS" lock:  
Enter SIM PIN of present card, followed by "PS" lock password.

```
AT+CPIN?
+CPIN: SIM PIN
OK
AT+CPIN="1111"
OK           PIN authentication accepted.
AT+CPIN?
+CPIN: PH-SIM PIN
OK           "PS" lock password is required.
AT+CPIN="3333"
OK           "PS" Lock password has been accepted. ME is fully operational now.
```

To deactivate the Phone Lock:

```
AT+CLCK="PS",0,"3333"     Phone Lock password has to be provided again.
OK           Now the mobile can be used with any SIM card, without the need of the
            phone lock password.
```

## 5.5 AT^SLCK Facility lock

**AT^SLCK** provides the "Facility lock" function as defined for the GSM 07.07 command **AT+CLCK**. The command can be used to lock, unlock or interrogate a network or ME **<facility>**.

**AT^SLCK** is, in every respect, identical with **AT+CLCK**, except that the command syntax and response prefix is "SLCK" instead of "+CLCK". For further details please refer to **AT+CLCK**.

The command can be aborted when network facilities are being set or interrogated.

### Syntax

#### Test Command

AT^SLCK=?

Response(s)

^SLCK: list of supported **<facility>**s

OK

#### Write Command

AT^SLCK=**<facility>**, **<mode>** [, **<password>**] [, **<class>**]

Response(s)

if **<mode>** is not equal 2 and command successful:

OK

if **<mode>**= 2 and command successful:

^SLCK: **<status>**, **<class>**

[^SLCK: **<status>**, **<class>**]

[^SLCK: ...]

OK

If error is related to ME functionality

+CME ERROR

#### Reference(s)

GSM 07.07, GSM 02.04,  
GSM 02.88, GSM 03.88, GSM 04.88

PIN	ASC0	MUX1	MUX2	MUX3	Charge		Last
●	●	●	●	●	○	○	○





- “PS” Phone locked to SIM card. ME requests password when other than current SIM card is inserted.  
“PS” lock is frequently referred to as “phone lock”, or “device lock”. Accordingly, the password may be called “phone code” or “device code”. The “PS” password is not associated with the PUK of the SIM card. It must be defined before the first use of `<facility>` “PS” with `AT+CLCK`.  
`<password length>`: 4 digits.  
If incorrectly entered three times, the Master Phone Code is required to lift the lock. This Unblocking procedure is performed with `AT+CPWD` using the following parameters: `<facility>`="PS", `<old password>`= Master Phone Code (to be obtained from the module manufacturer), and `<new password>`= the new phone code (“PS” password for lock facility), if desired.  
Mind that successful PIN authentication is a prerequisite for use of AT command `AT+CPWD`. If Pin authentication has not been completed, input of the Master Phone code password is possible only with AT command `AT+CPIN` or `ATD`. For further detail please refer to Section 5.1.1, [What to do if PIN or password authentication fails?](#).  
Once the Master Phone Code has been accepted, the mobile is operational, and the “PS” lock is no longer active. If needed it must be set once again with `AT+CLCK`.
- “P2” SIM PIN 2, e.g. required for authentication with facility lock “FD” (cf. `AT+CLCK`). If incorrectly entered three times, the SIM PUK 2 is required to perform authentication. Input of the SIM PUK 2 password is possible only with AT command `AT+CPIN2` or `ATD`. For further detail please refer to Section 5.1.1, [What to do if PIN or password authentication fails?](#).  
`<password length>`: 4 to 8 digits.

#### Factory defined SIM locks:

Typical examples of factory set SIM locks are prepaid phones or network locks, used to restrict the operation of a mobile to a specific provider or operator. The client should be aware that each of these lock types can only be unlocked if the associated password is available. For example, a mobile can be locked to accept only SIM cards from the respective provider, or even one single SIM card. Once a different SIM card is inserted the ME will prompt the client to enter a specific code. This is not the PUK of the SIM card, but usually an 8-digit code which needs to be requested from the provider.

The locks can only be set by the manufacturer and need to be agreed upon between the parties concerned, e.g. provider, operator, distributor etc. on the one side and the manufacturer on the other side. For details contact your local dealer or Cinterion Wireless Modules GmbH.

- |      |                                       |
|------|---------------------------------------|
| “PF” | Lock Phone to the very First SIM card |
| “PN” | Network Personalisation               |
| “PU” | Network subset Personalisation        |
| “PP” | Service Provider Personalisation      |
| “PC” | Corporate Personalisation             |

#### Supplementary Service Call Barring:

Supplementary Service “Call Barring” allows to specify conditions under which calls will be disallowed by the network.

The availability of the Supplementary Services varies with the network. To benefit from call barring the client will need to subscribe them, though a limited number of call barring types may be included in the basic tariff package.

`<password length>`: The Network Password needs to be supplied from the network provider or network operator. Usually there is one 4 digit password which applies to all call barring options. For details contact your provider.

- |      |   |
|------|---|
| “AO” | BAOC (Bar All Outgoing Calls)                                       |
| “OI” | BOIC (Bar Outgoing International Calls)                             |
| “OX” | BOIC-exHC (Bar Outgoing International Calls except to Home Country) |
| “AI” | BAIC (Bar All Incoming Calls)                                       |

"IR"	BIC-Roam (Bar Incoming Calls when Roaming outside the home country)
"AB"	All Barring services
"AG"	All outGoing barring services
"AC"	All inComing barring services

`<password length>`<sup>(num)</sup>

4...8 Length of password. The range of permitted length for a password depends on the associated `<facility>`. It is available from the test command response, or in the description of parameter `<facility>`.

`<old password>`<sup>(str)</sup>

Password specified for the facility.  
 Parameter `<old password>` can be ignored if no old password was allocated to the facility.  
 Take into account that a password may have already been set by factory, or that the service is subject to a password issued by the provider. See notes above or contact provider.

`<new password>`<sup>(str)</sup>

New password. Mandatory, if `<old password>` was an unblocking key (such as the Master Phone Code).

**Note**

- When changing PIN2 (`<facility>="P2"`) it is recommended to check the new state of PIN2 by using the [AT+CPIN2](#) command.

**Examples**

EXAMPLE 1

To change PIN2

AT+CPWD="P2", "0000", "8888"	(where "0000" = old PIN2 and "8888" = new PIN2)
OK	PIN2 Password has been changed to "8888"

EXAMPLE 2

To set password used to enable or disable barring of all outgoing calls:

AT+CPWD="AO", "0000", "3333"	Requests the network to change the password for supplementary service "call barring".
OK	Usually this request will affect all barring services, even though the request is issued for Supplementary Service BAOC ("Barring of all outgoing calls") only. Refer to the respective network provider for detail.

EXAMPLE 3

Handling of the "PS" lock password

AT+CMEE=2	Enable text output of CME Error information
AT+CPWD="PS", "1111", "2222"	(where "1111" = old password and "2222" = new password)
OK	Password for facility "PS" is now "2222"
AT+CPWD="PS", "1111", "2222"	Repeat command to provoke error "incorrect password"
+CME ERROR: incorrect password	("1111" is no longer the correct password)

EXAMPLE 4

To specify a new "PS" lock password, after the old password was disabled (e.g. after three failed attempts to change the "PS" password): use the master phone code.

CAUTION: THIS TEST SHOULD BE PERFORMED ONLY IF THE CORRECT MASTER PHONE CODE FOR THE INDIVIDUAL ME USED IS DEFINITELY AVAILABLE! Otherwise the module used will be rendered useless until the correct master phone code is entered!:

```
AT+CPWD="PS", "12345678", "1111"
```

where 12345678 is the Master Phone Code and 1111 is the new password. You may also use `<new password>` to restore the former disabled password.

```
OK
```

Alternatively, without giving a new password:

```
AT+CPWD="PS", "12345678"
```

(where 12345678 is the Master Phone Code). Deactivates the present phone lock.

```
OK
```

## 5.7 AT^SPWD Change Password

The `AT^SPWD` command is, in every respect, identical with `AT+CPWD`, except that the command syntax and response prefix is "`^SPWD`" instead of "`+CPWD`".

Each password is a string of digits the length of which varies with the associated facility. The test command returns a list of pairs which represent the available facilities and the maximum length of the associated password.

See also AT commands `AT+CLCK` and `AT^SLCK` for more detail on the various lock features.

### Syntax

```
Test Command
AT^SPWD=?
Response(s)
^SPWD: list of supported ( <facility>, <password length> )
OK

Write Command
AT^SPWD=<facility>, <old password>[, <new password>]
Response(s)
New password has been registered for the facility lock function.
OK
If parameter <old password> was not correct:
+CME ERROR 16 (+CME ERROR: incorrect password)
If the password for the selected <facility> has been invalidated due to too many failed attempts:
+CME ERROR ...
If error is related to ME functionality:
+CME ERROR
```

PIN	ASC0	MUX1	MUX2	MUX3	Charge		Last
●	●	●	●	●	○	○	○

### Note

- When changing the PIN2 (`<facility>="P2"`) it is recommended to check the new state of PIN2 using the `AT+CPIN2` command.

## 6. Identification Commands

The AT Commands described in this chapter allow the external application to obtain various identification information related to the TC35i and linked entities.

### 6.1 ATI Display product identification information

The `ATI` execute command delivers a product information text.  
The 'Revision' information consists of the following parts: Version xx and variant yy of software release.

#### Syntax

Exec Command	ATI																
Response(s)	Siemens TC35i REVISION xx.yy OK																
Exec Command	ATI[<value>]																
Response(s)	[Gipsy Soft Protocolstack V2.550] OK																
Reference(s)	V.250																
	<table border="1"> <tr> <td>PIN</td> <td>ASC0</td> <td>MUX1</td> <td>MUX2</td> <td>MUX3</td> <td>Charge</td> <td></td> <td>Last</td> </tr> <tr> <td><input type="radio"/></td> <td><input checked="" type="radio"/></td> <td><input checked="" type="radio"/></td> <td><input checked="" type="radio"/></td> <td><input checked="" type="radio"/></td> <td><input type="radio"/></td> <td><input type="radio"/></td> <td><input type="radio"/></td> </tr> </table>	PIN	ASC0	MUX1	MUX2	MUX3	Charge		Last	<input type="radio"/>	<input checked="" type="radio"/>	<input checked="" type="radio"/>	<input checked="" type="radio"/>	<input checked="" type="radio"/>	<input type="radio"/>	<input type="radio"/>	<input type="radio"/>
PIN	ASC0	MUX1	MUX2	MUX3	Charge		Last										
<input type="radio"/>	<input checked="" type="radio"/>	<input checked="" type="radio"/>	<input checked="" type="radio"/>	<input checked="" type="radio"/>	<input type="radio"/>	<input type="radio"/>	<input type="radio"/>										

#### Parameter Description

<value> <sup>(num)</sup>	
9	Gipsy Soft Protocolstack V2.550

This information is delivered if `ATI` is used with the optional parameter `<value>9` (i.e. if `ATI9` is entered). Other values are not supported and only return OK.

## 6.2 AT+CGMI Request manufacturer identification

[AT+CGMI](#) returns a manufacturer identification text. See also: [AT+GMI](#).

### Syntax

Test Command	AT+CGMI=?																
Response(s)	OK																
Exec Command	AT+CGMI																
Response(s)	Siemens OK																
Reference(s)	GSM 07.07																
	<table border="1"><thead><tr><th>PIN</th><th>ASC0</th><th>MUX1</th><th>MUX2</th><th>MUX3</th><th>Charge</th><th></th><th>Last</th></tr></thead><tbody><tr><td><input type="radio"/></td><td><input checked="" type="radio"/></td><td><input checked="" type="radio"/></td><td><input checked="" type="radio"/></td><td><input checked="" type="radio"/></td><td><input type="radio"/></td><td><input type="radio"/></td><td><input type="radio"/></td></tr></tbody></table>	PIN	ASC0	MUX1	MUX2	MUX3	Charge		Last	<input type="radio"/>	<input checked="" type="radio"/>	<input checked="" type="radio"/>	<input checked="" type="radio"/>	<input checked="" type="radio"/>	<input type="radio"/>	<input type="radio"/>	<input type="radio"/>
PIN	ASC0	MUX1	MUX2	MUX3	Charge		Last										
<input type="radio"/>	<input checked="" type="radio"/>	<input checked="" type="radio"/>	<input checked="" type="radio"/>	<input checked="" type="radio"/>	<input type="radio"/>	<input type="radio"/>	<input type="radio"/>										

## 6.3 AT+GMI Request manufacturer identification

[AT+GMI](#) returns a manufacturer identification text. See also: [AT+CGMI](#).

### Syntax

Test Command	AT+GMI=?																
Response(s)	OK																
Exec Command	AT+GMI																
Response(s)	Siemens OK																
Reference(s)	V.250																
	<table border="1"><thead><tr><th>PIN</th><th>ASC0</th><th>MUX1</th><th>MUX2</th><th>MUX3</th><th>Charge</th><th></th><th>Last</th></tr></thead><tbody><tr><td><input type="radio"/></td><td><input checked="" type="radio"/></td><td><input checked="" type="radio"/></td><td><input checked="" type="radio"/></td><td><input checked="" type="radio"/></td><td><input type="radio"/></td><td><input type="radio"/></td><td><input type="radio"/></td></tr></tbody></table>	PIN	ASC0	MUX1	MUX2	MUX3	Charge		Last	<input type="radio"/>	<input checked="" type="radio"/>	<input checked="" type="radio"/>	<input checked="" type="radio"/>	<input checked="" type="radio"/>	<input type="radio"/>	<input type="radio"/>	<input type="radio"/>
PIN	ASC0	MUX1	MUX2	MUX3	Charge		Last										
<input type="radio"/>	<input checked="" type="radio"/>	<input checked="" type="radio"/>	<input checked="" type="radio"/>	<input checked="" type="radio"/>	<input type="radio"/>	<input type="radio"/>	<input type="radio"/>										

## 6.4 AT+CGMM Request model identification

[AT+CGMM](#) returns a product model identification text. Command is identical with [AT+GMM](#).

### Syntax

Test Command	
AT+CGMM=?	
Response(s)	
OK	
Exec Command	
AT+CGMM	
Response(s)	
TC35i	
OK	
Reference(s)	
GSM 07.07	
	PIN ASC0 MUX1 MUX2 MUX3 Charge  Last
	<input type="radio"/> <input checked="" type="radio"/> <input checked="" type="radio"/> <input checked="" type="radio"/> <input checked="" type="radio"/> <input type="radio"/> <input type="radio"/> <input type="radio"/>

## 6.5 AT+GMM Request model identification

[AT+GMM](#) returns a product model identification text. Command is identical with [AT+CGMM](#).

### Syntax

Test Command	
AT+GMM=?	
Response(s)	
OK	
Exec Command	
AT+GMM	
Response(s)	
TC35i	
OK	
Reference(s)	
V.250	
	PIN ASC0 MUX1 MUX2 MUX3 Charge  Last
	<input type="radio"/> <input checked="" type="radio"/> <input checked="" type="radio"/> <input checked="" type="radio"/> <input checked="" type="radio"/> <input type="radio"/> <input type="radio"/> <input type="radio"/>

## 6.6 AT+CGMR Request revision identification of software status

[AT+CGMR](#) delivers a product firmware version identification. Command is identical with [AT+GMR](#).

### Syntax

Test Command	AT+CGMR=?																
Response(s)	OK																
Exec Command	AT+CGMR																
Response(s)	REVISION <xx.yy> OK																
Reference(s)	GSM 07.07																
	<table border="1"> <thead> <tr> <th>PIN</th> <th>ASC0</th> <th>MUX1</th> <th>MUX2</th> <th>MUX3</th> <th>Charge</th> <th></th> <th>Last</th> </tr> </thead> <tbody> <tr> <td><input type="radio"/></td> <td><input checked="" type="radio"/></td> <td><input checked="" type="radio"/></td> <td><input checked="" type="radio"/></td> <td><input checked="" type="radio"/></td> <td><input type="radio"/></td> <td><input type="radio"/></td> <td><input type="radio"/></td> </tr> </tbody> </table>	PIN	ASC0	MUX1	MUX2	MUX3	Charge		Last	<input type="radio"/>	<input checked="" type="radio"/>	<input checked="" type="radio"/>	<input checked="" type="radio"/>	<input checked="" type="radio"/>	<input type="radio"/>	<input type="radio"/>	<input type="radio"/>
PIN	ASC0	MUX1	MUX2	MUX3	Charge		Last										
<input type="radio"/>	<input checked="" type="radio"/>	<input checked="" type="radio"/>	<input checked="" type="radio"/>	<input checked="" type="radio"/>	<input type="radio"/>	<input type="radio"/>	<input type="radio"/>										

### Parameter Description

<xx.yy> <sup>(str)</sup>
Version xx and variant yy of software release.

## 6.7 AT+GMR Request revision identification of software status

[AT+GMR](#) delivers a product firmware version identification. Command is identical with [AT+CGMR](#).

### Syntax

Test Command	AT+GMR=?																
Response(s)	OK																
Exec Command	AT+GMR																
Response(s)	REVISION <xx.yy> OK																
Reference(s)	V.250																
	<table border="1"> <thead> <tr> <th>PIN</th> <th>ASC0</th> <th>MUX1</th> <th>MUX2</th> <th>MUX3</th> <th>Charge</th> <th></th> <th>Last</th> </tr> </thead> <tbody> <tr> <td><input type="radio"/></td> <td><input checked="" type="radio"/></td> <td><input checked="" type="radio"/></td> <td><input checked="" type="radio"/></td> <td><input checked="" type="radio"/></td> <td><input type="radio"/></td> <td><input type="radio"/></td> <td><input type="radio"/></td> </tr> </tbody> </table>	PIN	ASC0	MUX1	MUX2	MUX3	Charge		Last	<input type="radio"/>	<input checked="" type="radio"/>	<input checked="" type="radio"/>	<input checked="" type="radio"/>	<input checked="" type="radio"/>	<input type="radio"/>	<input type="radio"/>	<input type="radio"/>
PIN	ASC0	MUX1	MUX2	MUX3	Charge		Last										
<input type="radio"/>	<input checked="" type="radio"/>	<input checked="" type="radio"/>	<input checked="" type="radio"/>	<input checked="" type="radio"/>	<input type="radio"/>	<input type="radio"/>	<input type="radio"/>										

### Parameter Description

<xx.yy> <sup>(text)</sup>
Version xx and variant yy of software release.



## 6.8 AT+CGSN Request International Mobile Equipment Identity (IMEI)

[AT+CGSN](#) delivers the International Mobile Equipment Identity (IMEI). Command is identical with: [AT+GSN](#).

### Syntax

Test Command																	
AT+CGSN=?																	
Response(s)																	
OK																	
Exec Command																	
AT+CGSN																	
Response(s)																	
<sn>																	
OK																	
Reference(s)																	
GSM 07.07	<table border="1"> <thead> <tr> <th>PIN</th> <th>ASC0</th> <th>MUX1</th> <th>MUX2</th> <th>MUX3</th> <th>Charge</th> <th></th> <th>Last</th> </tr> </thead> <tbody> <tr> <td><input type="radio"/></td> <td><input checked="" type="radio"/></td> <td><input checked="" type="radio"/></td> <td><input checked="" type="radio"/></td> <td><input checked="" type="radio"/></td> <td><input type="radio"/></td> <td><input type="radio"/></td> <td><input type="radio"/></td> </tr> </tbody> </table>	PIN	ASC0	MUX1	MUX2	MUX3	Charge		Last	<input type="radio"/>	<input checked="" type="radio"/>	<input checked="" type="radio"/>	<input checked="" type="radio"/>	<input checked="" type="radio"/>	<input type="radio"/>	<input type="radio"/>	<input type="radio"/>
PIN	ASC0	MUX1	MUX2	MUX3	Charge		Last										
<input type="radio"/>	<input checked="" type="radio"/>	<input checked="" type="radio"/>	<input checked="" type="radio"/>	<input checked="" type="radio"/>	<input type="radio"/>	<input type="radio"/>	<input type="radio"/>										

### Parameter Description

<sn><sup>(str)</sup>  
International Mobile Equipment Identity (IMEI) used to identify a GSM mobile equipment to the GSM network

## 6.9 AT+GSN Request International Mobile Equipment Identity (IMEI)

[AT+GSN](#) delivers the International Mobile Equipment Identity (IMEI). Command is identical with [AT+CGSN](#)

### Syntax

Test Command																	
AT+GSN=?																	
Response(s)																	
OK																	
Exec Command																	
AT+GSN																	
Response(s)																	
<sn>																	
OK																	
Reference(s)																	
V.250	<table border="1"> <thead> <tr> <th>PIN</th> <th>ASC0</th> <th>MUX1</th> <th>MUX2</th> <th>MUX3</th> <th>Charge</th> <th></th> <th>Last</th> </tr> </thead> <tbody> <tr> <td><input type="radio"/></td> <td><input checked="" type="radio"/></td> <td><input checked="" type="radio"/></td> <td><input checked="" type="radio"/></td> <td><input checked="" type="radio"/></td> <td><input type="radio"/></td> <td><input type="radio"/></td> <td><input type="radio"/></td> </tr> </tbody> </table>	PIN	ASC0	MUX1	MUX2	MUX3	Charge		Last	<input type="radio"/>	<input checked="" type="radio"/>	<input checked="" type="radio"/>	<input checked="" type="radio"/>	<input checked="" type="radio"/>	<input type="radio"/>	<input type="radio"/>	<input type="radio"/>
PIN	ASC0	MUX1	MUX2	MUX3	Charge		Last										
<input type="radio"/>	<input checked="" type="radio"/>	<input checked="" type="radio"/>	<input checked="" type="radio"/>	<input checked="" type="radio"/>	<input type="radio"/>	<input type="radio"/>	<input type="radio"/>										

### Parameter Description

<sn><sup>(str)</sup>  
International Mobile Equipment Identity (IMEI) used to identify a GSM mobile equipment to the GSM network.

## 6.10 AT+CIMI Request International Mobile Subscriber Identity (IMSI)

**AT+CIMI** delivers the International Mobile Subscriber Identity (IMSI). The IMSI permits the TE to identify the individual SIM attached to the ME.

### Syntax

Test Command AT+CIMI=? Response(s) OK																	
Exec Command AT+CIMI Response(s) <imsi> OK ERROR +CME ERROR: <err>																	
Reference(s) GSM 07.07	<table border="1"> <thead> <tr> <th>PIN</th> <th>ASC0</th> <th>MUX1</th> <th>MUX2</th> <th>MUX3</th> <th>Charge</th> <th></th> <th>Last</th> </tr> </thead> <tbody> <tr> <td>●</td> <td>●</td> <td>●</td> <td>●</td> <td>●</td> <td>○</td> <td>○</td> <td>○</td> </tr> </tbody> </table>	PIN	ASC0	MUX1	MUX2	MUX3	Charge		Last	●	●	●	●	●	○	○	○
PIN	ASC0	MUX1	MUX2	MUX3	Charge		Last										
●	●	●	●	●	○	○	○										

### Parameter Description

<imsi><sup>(str)</sup>  
International Mobile Subscriber Identity (string without quotes).

## 7. Call related Commands

The AT Commands described in this chapter are related to Mobile Originated (MOC, i.e. outgoing) Calls and Mobile Terminated (MTC, i.e. incoming) Calls.

### 7.1 ATA Answer a call

#### Syntax

Exec Command									
ATA									
Response(s)									
In case of data call, if successfully connected (TA switches to data mode):									
CONNECT <text>									
In case of voice call, if successfully connected:									
OK									
When TA returns to command mode after call release:									
OK									
If no connection:									
NO CARRIER									
Reference(s)		PIN	ASC0	MUX1	MUX2	MUX3	Charge		Last
V.250		●	●	●	●	●	○	○	○

#### Command Description

TA causes remote station to go off-hook (e.g. answer call).

#### Parameter Description

<text> <sup>(str)</sup>
Connection status
<text> output only if <b>ATX</b> parameter setting with value greater 0.

#### Notes

- Any additional commands on the same command line are ignored.
- The command may be aborted generally by receiving a character during execution. It can't be aborted in some connection setup states, such as handshaking.
- If **AT+FCLASS** setting is 1 or 2, all incoming calls will be answered as fax calls, when ATA is issued on multiplexer channel 1 resp. ASC0. For calls explicitly signalled as voice or data calls, this procedure will fail with result code "NO CARRIER", but the call in question will continue to ring. It is possible to change the setting for **AT+FCLASS** to 0 while the call is ringing, and accept the call normally afterwards with **ATA**.
- See also **ATX** for <text>.
- If an incoming call is no longer available (already disconnected/hanged up) a "NO CARRIER" result code will be given.

## 7.2 ATD Mobile originated call to specified number

### Syntax

Exec Command	
ATD<n>[<mgsms>][:;]	
Response(s)	
If no dialtone (parameter setting <a href="#">ATX2</a> or <a href="#">ATX4</a> ): NO DIALTONE	
If busy (parameter setting <a href="#">ATX3</a> or <a href="#">ATX4</a> ): BUSY	
If a connection cannot be set up: NO CARRIER OK	
If successfully connected and non-voice call (TA switches to online data mode): CONNECT <text>	
When TA returns to command mode after call release: OK	
If successfully connected and voice call: OK	
Reference(s)	PIN ASC0 MUX1 MUX2 MUX3 Charge  Last
V.250	

### Command Description

This command can be used to set up outgoing voice, data or fax calls. It also serves to control Supplementary Services. The termination character ";" is mandatory to set up voice calls or to send \*# codes for Supplementary Services. It must not be used for data and fax calls.

Additional notes on the responses returned after dialing with [ATD](#):

- For voice calls, you have the choice of two different response modes that can be selected with [AT^SM20](#):  
[AT^SM20=1](#) (factory default) causes the ME to respond once the call setup is completed either successfully ("OK") or unsuccessfully ("NO CARRIER", "NO DIAL TONE", "BUSY").  
[AT^SM20=0](#) causes the ME to return "OK" immediately after dialing was completed (i.e. before call setup terminates successfully or unsuccessfully).
- For data connections, call setup always terminates when the call has been established (indicated by the result code "CONNECT <text>"), or when it fails (indicated by "NO CARRIER"). The settings of [AT^SM20](#) do not apply.

Different call release indications:

- Upon termination, an outgoing fax or data call may show a different result code than a voice call would show under identical conditions. In order to track down the actual reason for call termination, [AT+CEER](#) or [ATS18](#) should be used for all applicable connections.

Using [ATD](#) during an active call:

- When a user originates a second voice call while there is already an active voice call, the first call will automatically put on hold. The second call attempt is acknowledged with "OK" immediately after dialing with [ATD](#) has completed, without relation to a successful call setup. In case of failure, the additional result codes "NO CARRIER", "NO DIAL TONE", "NO CARRIER" will be presented afterwards (see example below).

### Parameter Description

<n> <sup>(text)</sup>
String of dialing digits and optional V.250 modifiers: 0-9, *, #, +, A, B, C The following V.250 modifiers are ignored: ,(comma), T, P, !, W ,@ Emergency call : <n> = 112, standardized GSM emergency number (no SIM needed).

<mgsM><sup>(str)</sup>

String of GSM modifiers:

- I Activates CLIR (disables presentation of own phone number to called party)
- i Deactivates CLIR (enables presentation of own phone number to called party)
- G Activate Closed User Group explicit invocation for this call only.
- g Deactivate Closed User Group explicit invocation for this call only.

### Notes

- The command may be aborted generally when receiving a character during execution. It cannot be aborted in some connection setup states, such as handshaking.
- Parameter "I" and "i" only if no \*#-code is within the dial string.
- <mgsM> is not supported for data calls.
- <n> is default for last number that can be dialed by ATDL.
- See also ATX for <text>.
- If ATD is used with a USSD command (e.g. ATD\*100#;) an AT+CUSD=1 is executed implicitly (see AT+CUSD).
- Parameter 'G' or 'g' will be ignored if Closed User Group was already activated, respectively deactivated with AT+CCUG command before. Call by call invocation of CUG uses the settings provisioned by the provider or, if available, the settings of the parameters <index> and <info> made with AT+CCUG.
- The ME is equipped with a "Blacklist" function according to GSM02.07 Annex A:  
After a predefined number of failed call attempts, the dialed number is entered into a read-only phonebook called "blacklist" (phonebook "BL"). Call attempts to numbers contained in the blacklist will be barred by ME and not signalled to the network.  
An attempt to start a voice call to a barred phone number will be stopped with a CME ERROR 257 "C all Barred".  
An attempt to start a data or fax call to a barred phone number will be answered immediately with result code "NO CARRIER".  
The barred numbers are automatically removed from the blacklist according to the timing conditions specified in GSM02.07 Annex A.
- To start the ATD command automatically on DTR signal activation AT%D may be used.

### Example

The following example shows the call setup procedure when a call is already active and a second call attempt fails because the line of the called party is busy:

atd03012345678	Dialing out the first party's number.
OK	The first call is established.
ATD03022222222	The number of the second party is dialed.
OK	The response "OK" is issued immediately though no call is established (same behavior as is you had chosen AT^SM20=0.)
BUSY	Line of the second called party is busy.

## 7.3 ATD><mem><n> Mobile originated call using specific memory and index number

### Syntax

Exec Command	
ATD><mem><n>[<mgsm>];	
Response(s)	
ERROR	
+CME ERROR: <err>	
If no dialtone (parameter ATX2 or ATX4):	
NO DIALTONE	
If busy (parameter setting ATX3 or ATX4):	
BUSY	
If connection cannot be set up:	
NO CARRIER	
When TA returns to command mode after call release:	
OK	
If successfully connected:	
OK	
Reference(s)	PIN ASC0 MUX1 MUX2 MUX3 Charge  Last
V.250	<input type="checkbox"/> <input type="checkbox"/> <input type="checkbox"/> <input type="checkbox"/> <input type="checkbox"/> <input type="checkbox"/> <input type="checkbox"/> <input type="checkbox"/>

### Command Description

TA attempts to set up an outgoing call to the specified number. The termination character ";" is mandatory since dialing from a phonebook is only supported for voice calls and for sending \*# codes of Supplementary Services or other functions.

### Parameter Description

<mem><sup>(str)</sup>

Phonebook storage:

For detailed description of storages see [AT+CPBS](#).

"FD"	Fixed dialing phonebook
"SM"	SIM phonebook
"ON"	MSISDN list
"ME"	Mobile Equipment Phonebook
"LD"	Last number dialed phonebook
"MC"	Missed (unanswered received) calls list
"RC"	Received calls list

<n><sup>(num)</sup>

Integer type memory location in the range of locations available in the selected memory, i.e. the index number returned by [AT+CPBR](#).

<mgsm><sup>(str)</sup>

String of GSM modifiers:

- l Activates CLIR (disables presentation of own phone number to called party)
- i Deactivates CLIR (enables presentation of own phone number to called party)

### Notes

- This command may be aborted generally by receiving a character during execution. Abortion is not possible during some states of connection setup such as handshaking.
- There is no <mem> for emergency call ("EN").
- The command is not applicable to data calls. Any attempt to dial a data call number from <mem> causes the result code "NO CARRIER" to appear.
- Parameter <mgsm> only if no \*# code is within the dialing string.
- See [ATX](#) for setting result code and call monitoring parameters.

### Examples

#### EXAMPLE 1

To query the location number of the phonebook entry:

```
AT+CPBR=1,xx
```

TA returns the entries available in the active phonebook.

#### EXAMPLE 2

To dial a number from the SIM phonebook, for example the number stored to location 15:

```
ATD>SM15 ;  
OK
```

#### EXAMPLE 3

To dial a phone number stored in the last dial memory on the SIM card:

```
ATD>LD9 ;  
OK
```

## 7.4 ATD<n> Mobile originated call from active memory using index number

### Syntax

Exec Command	
ATD<n>[<mgsms>];	
Response(s)	
ERROR	
+CME ERROR: <err>	
If no dialtone (parameter ATX2 or ATX4):	
NO DIALTONE	
If busy (parameter setting ATX3 or ATX4):	
BUSY	
If connection cannot be set up:	
NO CARRIER	
When TA returns to command mode after call release:	
OK	
If successfully connected:	
OK	
Reference(s)	PIN ASC0 MUX1 MUX2 MUX3 Charge  Last
V.250	<input type="checkbox"/> <input type="checkbox"/> <input type="checkbox"/> <input type="checkbox"/> <input type="checkbox"/> <input type="checkbox"/> <input type="checkbox"/> <input type="checkbox"/>

### Command Description

TA attempts to set up an outgoing call to the stored number. The termination character ";" is mandatory since dialing from a phonebook is only supported for voice calls and for sending \*# codes of Supplementary Services or other functions.

### Parameter Description

<n><sup>(num)</sup>

Integer type memory location in the range of locations available in the selected memory, i.e. the index number returned by [AT+CPBR](#).

<mgsms><sup>(str)</sup>

String of GSM modifiers:

- l Activates CLIR (disables presentation of own phone number to called party)
- i Deactivates CLIR (enables presentation of own phone number to called party)

### Notes

- This command may be aborted generally by receiving a character during execution. Abortion is not possible during some states of connection setup such as handshaking.
- The command is not applicable to data calls. Any attempt to dial a data call number from <n> causes the result code "NO CARRIER" to appear.
- Parameter <mgsms> only if no \*# code is within the dialing string.



## 7.5 ATD><str> Mobile originated call from active memory using corresponding field

### Syntax

Exec Command	
ATD><str>[<mgsms>];	
Response(s)	
ERROR	
+CME ERROR: <err>	
If no dialtone (parameter ATX2 or ATX4):	
NO DIALTONE	
If busy (parameter setting ATX3 or ATX4):	
BUSY	
If connection cannot be set up:	
NO CARRIER	
When TA returns to command mode after call release:	
OK	
If successfully connected:	
OK	
Reference(s)	PIN ASC0 MUX1 MUX2 MUX3 Charge  Last
V.250	<input checked="" type="checkbox"/> <input checked="" type="checkbox"/> <input checked="" type="checkbox"/> <input type="checkbox"/> <input type="checkbox"/> <input type="checkbox"/> <input type="checkbox"/> <input type="checkbox"/>

### Command Description

This command searches the active phonebook for a given string <str> and dials the assigned phone number. The termination character ";" is mandatory since dialing from a phonebook is only supported for voice calls and for sending \*# codes of Supplementary Services or other functions.

### Parameter Description

<str><sup>(str)(+CSCS)</sup>

String type value ("x"), which should equal an alphanumeric field in at least one phonebook entry in the searched memories; used character set should be the one selected with AT+CSCS. <str> can contain escape sequences as described in chapter "Supported character sets".

<str> must be wrapped in quotation marks (""), if escape sequences or parameter <mgsms> are used or if the alphanumeric strings contains a blank. If not, quotation marks are optional.

If AT+CSCS is set to "UCS2", with respect to the coding of UCS2-characters only phonebook entries that contain an alphanumeric string with a size less than the half of the parameter <tlength> from AT+CPBW can be dialed.

<mgsms><sup>(str)</sup>

String of GSM modifiers:

- l Activates CLIR (disables presentation of own phone number to called party)
- i Deactivates CLIR (enables presentation of own phone number to called party)

### Notes

- This command may be aborted generally by receiving a character during execution. Abortion is not possible during some states of connection setup such as handshaking.
- The command is not applicable to data calls. Any attempt to dial <str> without semicolon ";" causes the result code "NO CARRIER" to appear.
- Parameter <mgsms> only if no \*# code is within the dialing string.

## 7.6 ATDI Mobile originated call to ISDN number

### Syntax

Exec Command	
ATDI<n>[:]	
Response(s)	
If no dialtone (parameter ATX2 or ATX4): NO DIALTONE	
If busy (parameter setting ATX3 or ATX4): BUSY	
If connection cannot be set up: NO CARRIER	
All other error reasons: +CME ERROR	
If successfully connected and non-voice call (TA switches to data state): CONNECT <text>	
When TA returns to command mode after call release: OK	
If successfully connected and voice call: OK	
Reference(s)	PIN ASC0 MUX1 MUX2 MUX3 Charge Last
V.250	● ● ● ○ ○ ○ ○ ○

### Command Description

TA attempts to set up an outgoing call to ISDN number. The termination character ";" is mandatory to set up voice calls or to send \*# codes for Supplementary Services. It must not be used for data and fax calls.

### Parameter Description

<n> <sup>(str)</sup>
ISDN number String with maximum length of 20 characters. Allowed characters: +, 0-9, A, B, C.

### Note

- This command may be aborted generally by receiving a character during execution. Abortion is not possible during some states of connection setup such as handshaking.

## 7.7 ATDL Redial last number used

### Syntax

Exec Command	
ATDL[:]	
Response(s)	
If there is no last number or number is not valid: +CME ERROR	
If no dialtone (parameter ATX2 or ATX4): NO DIALTONE	
If busy (parameter setting ATX3 or ATX4): BUSY	
If connection cannot be set up: NO CARRIER	
If successfully connected and non-voice call (TA switches to online data mode): CONNECT <text>	
When TA returns to command mode after call release: OK	
If successfully connected and voice call: OK	
Reference(s)	PIN ASC0 MUX1 MUX2 MUX3 Charge Last
V.250	● ● ● ◐ ◐ ○ ○ ○

### Command Description



This command redials the last voice and data call number used in the ATD command. If terminated with semi-colon ";", ATDL dials the last voice call number stored in the "LD" phonebook. Otherwise, the last dialed data or fax number will be used (not contained in the "LD" phonebook).

### Notes

- This command may be aborted generally by receiving a character during execution. Abortion is not possible during some states of connection setup such as handshaking.
- Parameter "l" and "i" only if no \*#-code is within the dial string.

## 7.8 ATH Disconnect existing connection

### Syntax

Exec Command																	
ATH[<n>]																	
Response(s)																	
OK																	
Reference(s)	<table border="1"> <thead> <tr> <th>PIN</th> <th>ASC0</th> <th>MUX1</th> <th>MUX2</th> <th>MUX3</th> <th>Charge</th> <th></th> <th>Last</th> </tr> </thead> <tbody> <tr> <td><input type="radio"/></td> <td><input checked="" type="radio"/></td> <td><input checked="" type="radio"/></td> <td><input checked="" type="radio"/></td> <td><input checked="" type="radio"/></td> <td><input type="radio"/></td> <td><input type="radio"/></td> <td><input type="radio"/></td> </tr> </tbody> </table>	PIN	ASC0	MUX1	MUX2	MUX3	Charge		Last	<input type="radio"/>	<input checked="" type="radio"/>	<input checked="" type="radio"/>	<input checked="" type="radio"/>	<input checked="" type="radio"/>	<input type="radio"/>	<input type="radio"/>	<input type="radio"/>
PIN	ASC0	MUX1	MUX2	MUX3	Charge		Last										
<input type="radio"/>	<input checked="" type="radio"/>	<input checked="" type="radio"/>	<input checked="" type="radio"/>	<input checked="" type="radio"/>	<input type="radio"/>	<input type="radio"/>	<input type="radio"/>										
V.250																	

### Command Description

Disconnect existing call from command line by local TE and terminate call.

### Parameter Description

<n> <sup>(num)</sup>	
[0]	disconnect from line and terminate call

### Notes

- OK is issued after circuit 109 (DCD) is turned off, if it was previously on.
- ATH terminates every circuit switched call (voice, data or fax), even if it is issued via another interface. This behavior is in accordance with ITU-T V.250; (07/97, "Hook control": "ATH is terminating any call in progress.>").

## 7.9 AT+CHUP Hang up call

### Syntax

Test Command	
AT+CHUP=?	
Response(s)	
OK	
ERROR	
+CME ERROR	
Exec Command	
AT+CHUP	
Response(s)	
OK	
ERROR	
+CME ERROR	
Reference(s)	
GSM 07.07	

PIN	ASC0	MUX1	MUX2	MUX3	Charge		Last
●	●	●	●	●	○	○	○

### Command Description

Cancels all active and held calls.

### Note

- [AT+CHUP](#) implements the same behaviour as [ATH](#).

## 7.10 AT^SHUP Hang up call(s) indicating a specific GSM04.08 release cause

### Syntax

Test Command	AT^SHUP=?																
Response(s)	OK																
Write Command	AT^SHUP=<cause>[, <cn>]																
Response(s)	ERROR OK																
Reference(s)	<table border="1"> <thead> <tr> <th>PIN</th> <th>ASC0</th> <th>MUX1</th> <th>MUX2</th> <th>MUX3</th> <th>Charge</th> <th></th> <th>Last</th> </tr> </thead> <tbody> <tr> <td>●</td> <td>●</td> <td>●</td> <td>●</td> <td>●</td> <td>○</td> <td>○</td> <td>○</td> </tr> </tbody> </table>	PIN	ASC0	MUX1	MUX2	MUX3	Charge		Last	●	●	●	●	●	○	○	○
PIN	ASC0	MUX1	MUX2	MUX3	Charge		Last										
●	●	●	●	●	○	○	○										

### Command Description

The write command serves to end one specific call or all calls known to the ME, indicating a specific GSM04.08 release cause specified by the user. The command can be used for voice, fax and data calls in any call status (i.e. any calls listed by [AT+CLCC](#)).

### Parameter Description

<cause> <sup>(num)</sup>	
release cause	
Release cause from GSM04.08 to be indicated to the network. The TC35i will release the selected connection(s) with release cause indication "cause" and location "user" (0) in the "disconnect" protocol message to the GSM Network. It depends on the network whether or not the release cause will be forwarded to the remote party.	
1	send GSM04.08 release cause "unassigned (unallocated) number"
16	send GSM04.08 release cause "Normal call clearing "
17	send GSM04.08 release cause "User busy "
18	send GSM04.08 release cause "No user responding "
27	send GSM04.08 release cause "Destination out of order "
31	send GSM04.08 release cause "Normal, unspecified"

<cn> <sup>(num)</sup>	
call number	
The "call number" is an optional index into the list of current calls available via <a href="#">AT+CLCC</a> . AT command <a href="#">AT^SHUP</a> will terminate the call identified by the specified call number. The default call number "0" is not assigned to any call, but signifies "all calls". As "0" is the default value, it may be omitted. With <a href="#">AT^SHUP</a> , Calls will be terminated regardless of their current call status, which may be any of the states allowed by <a href="#">AT+CLCC</a> .	
[0]	terminate all known calls
1...7	terminate the specific call number <cn>

---

**Notes**

- it depends on the network whether or not a delivered release cause will be forwarded to the remote party.
- With [AT^SHUP](#), Calls will be terminated regardless of their current call status, which may be any of the states allowed by [AT+CLCC](#).

## 7.11 ATSO Set number of rings before automatically answering a call

This command determines the number of rings before automatic answering a call.

### Syntax

Read Command																	
ATSO?																	
Response(s)																	
<n>																	
OK																	
ERROR																	
Write Command																	
ATSO=<n>																	
Response(s)																	
OK																	
ERROR																	
Reference(s)	<table border="1"> <tr> <td>PIN</td> <td>ASC0</td> <td>MUX1</td> <td>MUX2</td> <td>MUX3</td> <td>Charge</td> <td></td> <td>Last</td> </tr> <tr> <td>V.250</td> <td><input type="radio"/></td> <td><input checked="" type="radio"/></td> <td><input checked="" type="radio"/></td> <td><input checked="" type="radio"/></td> <td><input checked="" type="radio"/></td> <td><input type="radio"/></td> <td><input type="radio"/></td> </tr> </table>	PIN	ASC0	MUX1	MUX2	MUX3	Charge		Last	V.250	<input type="radio"/>	<input checked="" type="radio"/>	<input checked="" type="radio"/>	<input checked="" type="radio"/>	<input checked="" type="radio"/>	<input type="radio"/>	<input type="radio"/>
PIN	ASC0	MUX1	MUX2	MUX3	Charge		Last										
V.250	<input type="radio"/>	<input checked="" type="radio"/>	<input checked="" type="radio"/>	<input checked="" type="radio"/>	<input checked="" type="radio"/>	<input type="radio"/>	<input type="radio"/>										

### Parameter Description

<n> <sup>(num)(&amp;W)(&amp;V)</sup>	
000 <sup>(&amp;F)</sup>	Automatic answer mode is disabled.
001-255	Enable automatic answering after specified number of rings.



### Notes

- This command works for MT data, fax and voice calls. Auto answering for voice calls can be disabled by the command `AT^SCFG="Call/ATSO/CSV","disabled"`.
- Autoanswering of CSD data and fax calls is supported on ASC0/Mux1 only.
- If <n> is set to higher values, the calling party may hang up before the call is automatically answered.
- The correlation between [ATS7](#) and [ATSO](#) is important.  
Example: Call setup may fail if `ATS7=30` and `ATSO=20`.
- Setting is local to the interface. It is allowed to have different settings on different interfaces. In such cases the interface 'wins', which is idle and uses the smallest <n> value.



## 7.12 ATS6 Set pause before blind dialing

### Syntax

Read Command																	
ATS6?																	
Response(s)																	
<n>																	
OK																	
Write Command																	
ATS6=<n>																	
Response(s)																	
OK																	
ERROR																	
Reference(s)																	
V.250																	
	<table border="1"><tr><td>PIN</td><td>ASC0</td><td>MUX1</td><td>MUX2</td><td>MUX3</td><td>Charge</td><td></td><td>Last</td></tr><tr><td><input type="radio"/></td><td><input checked="" type="radio"/></td><td><input checked="" type="radio"/></td><td><input type="radio"/></td><td><input type="radio"/></td><td><input type="radio"/></td><td><input type="radio"/></td><td><input type="radio"/></td></tr></table>	PIN	ASC0	MUX1	MUX2	MUX3	Charge		Last	<input type="radio"/>	<input checked="" type="radio"/>	<input checked="" type="radio"/>	<input type="radio"/>	<input type="radio"/>	<input type="radio"/>	<input type="radio"/>	<input type="radio"/>
PIN	ASC0	MUX1	MUX2	MUX3	Charge		Last										
<input type="radio"/>	<input checked="" type="radio"/>	<input checked="" type="radio"/>	<input type="radio"/>	<input type="radio"/>	<input type="radio"/>	<input type="radio"/>	<input type="radio"/>										

### Command Description

No effect for GSM.

### Parameter Description

<n> <sup>(num)(&amp;W)(&amp;V)</sup>
000 <sup>(&amp;F)</sup> ...255

## 7.13 ATS7 Set number of seconds to wait for connection completion

**ATS7** specifies the number of seconds the TA will wait for the completion of the call setup when answering or originating a data call. Also referred to as "no answer timeout". To put it plainly, this is the time to wait for the carrier signal. If no carrier signal is received within the specified time, the TA hangs up.

### Syntax

Read Command																	
ATS7?																	
Response(s)																	
<n>																	
OK																	
Write Command																	
ATS7=<n>																	
Response(s)																	
OK																	
ERROR																	
Reference(s)	<table border="1"> <tr> <td>PIN</td> <td>ASC0</td> <td>MUX1</td> <td>MUX2</td> <td>MUX3</td> <td>Charge</td> <td></td> <td>Last</td> </tr> <tr> <td>V.250</td> <td><input type="radio"/></td> <td><input checked="" type="radio"/></td> <td><input checked="" type="radio"/></td> <td><input type="radio"/></td> <td><input type="radio"/></td> <td><input type="radio"/></td> <td><input type="radio"/></td> </tr> </table>	PIN	ASC0	MUX1	MUX2	MUX3	Charge		Last	V.250	<input type="radio"/>	<input checked="" type="radio"/>	<input checked="" type="radio"/>	<input type="radio"/>	<input type="radio"/>	<input type="radio"/>	<input type="radio"/>
PIN	ASC0	MUX1	MUX2	MUX3	Charge		Last										
V.250	<input type="radio"/>	<input checked="" type="radio"/>	<input checked="" type="radio"/>	<input type="radio"/>	<input type="radio"/>	<input type="radio"/>	<input type="radio"/>										

### Parameter Description

<n> <sup>(num)(&amp;W)(&amp;V)</sup>
Number of seconds to wait for connection completion
000...060 <sup>(&amp;F)</sup>

### Notes

- Command **ATS7** is only applicable to data calls.
- Values greater than 60 cause no error, but <n> will be restored to the maximum value of 60.
- The correlation between **ATS7** and **ATS0** is important. If the called party has specified a high value for **ATS0=<n>** call setup may fail.  
Example: Call setup may fail if **ATS7=30** and **ATS0=20**.

## 7.14 AT58 Set number of seconds to wait for comma dialing modifier

This command specifies the amount of time, in seconds, that the DCE shall pause, during signalling of call addressing information to the network (dialling), when a "," (comma) dial modifier is encountered in a dial string.

### Syntax

Read Command																	
AT58?																	
Response(s)																	
<b>&lt;n&gt;</b>																	
OK																	
Write Command																	
AT58= <b>&lt;n&gt;</b>																	
Response(s)																	
OK																	
ERROR																	
Reference(s)	<table border="1"> <tr> <td>PIN</td> <td>ASC0</td> <td>MUX1</td> <td>MUX2</td> <td>MUX3</td> <td>Charge</td> <td></td> <td>Last</td> </tr> <tr> <td><input type="radio"/></td> <td><input checked="" type="radio"/></td> <td><input checked="" type="radio"/></td> <td><input type="radio"/></td> <td><input type="radio"/></td> <td><input type="radio"/></td> <td><input type="radio"/></td> <td><input type="radio"/></td> </tr> </table>	PIN	ASC0	MUX1	MUX2	MUX3	Charge		Last	<input type="radio"/>	<input checked="" type="radio"/>	<input checked="" type="radio"/>	<input type="radio"/>	<input type="radio"/>	<input type="radio"/>	<input type="radio"/>	<input type="radio"/>
PIN	ASC0	MUX1	MUX2	MUX3	Charge		Last										
<input type="radio"/>	<input checked="" type="radio"/>	<input checked="" type="radio"/>	<input type="radio"/>	<input type="radio"/>	<input type="radio"/>	<input type="radio"/>	<input type="radio"/>										
V.250																	

### Command Description

No effect for GSM.

### Parameter Description

<b>&lt;n&gt;</b> <sup>(num)(&amp;W)(&amp;V)</sup>	
0 <sup>(&amp;F)</sup>	DCE does not pause when "," encountered in dial string
1...255	Number of seconds to pause

## 7.15 AT510 Set disconnect delay after indicating the absence of data carrier

### Syntax

Read Command																	
AT510?																	
Response(s)																	
<n>																	
OK																	
Write Command																	
AT510=<n>																	
Response(s)																	
OK																	
ERROR																	
Reference(s)	<table border="1"> <tr> <td>PIN</td> <td>ASC0</td> <td>MUX1</td> <td>MUX2</td> <td>MUX3</td> <td>Charge</td> <td></td> <td>Last</td> </tr> <tr> <td><input type="radio"/></td> <td><input checked="" type="radio"/></td> <td><input checked="" type="radio"/></td> <td><input type="radio"/></td> <td><input type="radio"/></td> <td><input type="radio"/></td> <td><input type="radio"/></td> <td><input type="radio"/></td> </tr> </table>	PIN	ASC0	MUX1	MUX2	MUX3	Charge		Last	<input type="radio"/>	<input checked="" type="radio"/>	<input checked="" type="radio"/>	<input type="radio"/>	<input type="radio"/>	<input type="radio"/>	<input type="radio"/>	<input type="radio"/>
PIN	ASC0	MUX1	MUX2	MUX3	Charge		Last										
<input type="radio"/>	<input checked="" type="radio"/>	<input checked="" type="radio"/>	<input type="radio"/>	<input type="radio"/>	<input type="radio"/>	<input type="radio"/>	<input type="radio"/>										
V.250																	

### Command Description

This parameter setting determines the amount of time, that the TA remains connected in absence of a data carrier. If the data carrier is detected before disconnect, the TA remains connected.

### Parameter Description

<n> <sup>(num)(&amp;W)(&amp;V)</sup>
number of tenths of seconds of delay
001...2 <sup>(&amp;F)</sup> ...254

## 7.16 ATO Switch from command mode to data mode

### Syntax

```
Exec Command
ATO[<n>]
Response(s)
If connection is not successfully resumed:
NO CARRIER
or
TA returns to data mode from command mode
CONNECT <text>
Note: <text> output only if ATX parameter setting with value > 0.
```

Reference(s)	PIN	ASC0	MUX1	MUX2	MUX3	Charge		Last
V.250	<input type="radio"/>	<input checked="" type="radio"/>	<input checked="" type="radio"/>	<input type="radio"/>	<input type="radio"/>	<input type="radio"/>	<input type="radio"/>	<input type="radio"/>

### Command Description

ATO is the corresponding command to the +++ escape sequence: When you have established a CSD call and TA is in command mode, ATO causes the TA to resume the data connection and takes you back to data mode.

### Parameter Description

<n> <sup>(num)</sup>
[0] Switch from command mode to data mode

## 7.17 +++ Switch from data mode to command mode

### Syntax

Exec Command	
+++	
Response(s)	
OK	
Reference(s)	PIN ASC0 MUX1 MUX2 MUX3 Charge  Last
V.250	<input type="radio"/> <input checked="" type="radio"/> <input checked="" type="radio"/> <input checked="" type="radio"/> <input checked="" type="radio"/> <input type="radio"/> <input type="radio"/> <input type="radio"/>

### Command Description

This command is only available during a data call. The +++ character sequence causes the TA to cancel the data flow over the AT interface and switch to command mode. This allows you to enter AT commands while maintaining the data connection to the remote device.

To prevent the +++ escape sequence from being misinterpreted as data, it must be preceded and followed by a pause of at least 1000 ms. The +++ characters must be entered in quick succession, all within 1000 ms.

### Note

- To return from command mode to data mode: Enter [ATO](#).

## 7.18 AT+CBST Select bearer service type

The **AT+CBST** write command selects the bearer service **<name>**, the data rate **<speed>** and the connection element **<ce>** to be used when data calls are originated. The settings also apply to mobile terminated data calls, especially when single numbering scheme calls or calls from analog devices are received (see **AT+CSNS**). See GSM 02.02[1] for a list of allowed combinations of subparameters.

### Syntax

<p>Test Command</p> <p>AT+CBST=?</p> <p>Response(s)</p> <p>+CBST: (list of supported&lt;speed&gt;s), (list of supported&lt;name&gt;s), (list of supported&lt;ce&gt;s)</p> <p>OK</p>																	
<p>Read Command</p> <p>AT+CBST?</p> <p>Response(s)</p> <p>+CBST: &lt;speed&gt;, &lt;name&gt;, &lt;ce&gt;</p> <p>OK</p>																	
<p>Write Command</p> <p>AT+CBST=&lt;speed&gt;[, &lt;name&gt;[, &lt;ce&gt;]]</p> <p>Response(s)</p> <p>OK</p> <p>ERROR</p>																	
<p>Reference(s)</p> <p>GSM 07.07</p>	<table border="1"> <tr> <td>PIN</td> <td>ASC0</td> <td>MUX1</td> <td>MUX2</td> <td>MUX3</td> <td>Charge</td> <td>⚡</td> <td>Last</td> </tr> <tr> <td><input type="radio"/></td> <td><input checked="" type="radio"/></td> <td><input checked="" type="radio"/></td> <td><input type="radio"/></td> <td><input type="radio"/></td> <td><input type="radio"/></td> <td><input type="radio"/></td> <td><input type="radio"/></td> </tr> </table>	PIN	ASC0	MUX1	MUX2	MUX3	Charge	⚡	Last	<input type="radio"/>	<input checked="" type="radio"/>	<input checked="" type="radio"/>	<input type="radio"/>	<input type="radio"/>	<input type="radio"/>	<input type="radio"/>	<input type="radio"/>
PIN	ASC0	MUX1	MUX2	MUX3	Charge	⚡	Last										
<input type="radio"/>	<input checked="" type="radio"/>	<input checked="" type="radio"/>	<input type="radio"/>	<input type="radio"/>	<input type="radio"/>	<input type="radio"/>	<input type="radio"/>										

### Parameter Description

<b>&lt;speed&gt;</b> <sup>(num)(&amp;W)(&amp;V)</sup>	
0	Autobauding
4	2400 bps (V.22bis)
6	4800 bps (V.32)
[7] <sup>(&amp;F)</sup>	9600 bps (V.32)
14	14400 bps (V.34)
68	2400 bps (V.110)
70	4800 bps (V.110)
71	9600 bps (V.110)
75	14400 bps (V.110)
<b>&lt;name&gt;</b> <sup>(num)(&amp;W)</sup>	
0 <sup>(&amp;F)</sup>	Asynchronous modem
<b>&lt;ce&gt;</b> <sup>(num)(&amp;W)</sup>	
Transparent mode is not supported.	
1 <sup>(&amp;F)</sup>	Non-transparent

## 7.19 AT+CRLP Select radio link protocol parameters for originated non-transparent data calls

The [AT+CRLP](#) write command sets radio link protocol (RLP) parameters used when non-transparent data calls are originated. The read command returns the current settings for the supported RLP version 0.

### Syntax

<p>Test Command</p> <pre>AT+CRLP=?</pre> <p>Response(s)</p> <pre>+CRLP: (list of supported&lt;iws&gt;s), (list of supported&lt;mws&gt;s), (list of supported&lt;T1&gt;s), (list of supported&lt;N2&gt;s) OK</pre>																	
<p>Read Command</p> <pre>AT+CRLP?</pre> <p>Response(s)</p> <pre>+CRLP: &lt;iws&gt;, &lt;mws&gt;, &lt;T1&gt;, &lt;N2&gt; OK</pre>																	
<p>Write Command</p> <pre>AT+CRLP=[&lt;iws&gt;[, &lt;mws&gt;[, &lt;T1&gt;[, &lt;N2&gt;]]]]</pre> <p>Response(s)</p> <pre>OK ERROR +CME ERROR: &lt;err&gt;</pre>																	
<p>Reference(s)</p> <p>GSM 07.07</p>	<table border="1"> <thead> <tr> <th>PIN</th> <th>ASC0</th> <th>MUX1</th> <th>MUX2</th> <th>MUX3</th> <th>Charge</th> <th></th> <th>Last</th> </tr> </thead> <tbody> <tr> <td><input type="radio"/></td> <td><input checked="" type="radio"/></td> <td><input checked="" type="radio"/></td> <td><input type="radio"/></td> <td><input type="radio"/></td> <td><input type="radio"/></td> <td><input type="radio"/></td> <td><input type="radio"/></td> </tr> </tbody> </table>	PIN	ASC0	MUX1	MUX2	MUX3	Charge		Last	<input type="radio"/>	<input checked="" type="radio"/>	<input checked="" type="radio"/>	<input type="radio"/>	<input type="radio"/>	<input type="radio"/>	<input type="radio"/>	<input type="radio"/>
PIN	ASC0	MUX1	MUX2	MUX3	Charge		Last										
<input type="radio"/>	<input checked="" type="radio"/>	<input checked="" type="radio"/>	<input type="radio"/>	<input type="radio"/>	<input type="radio"/>	<input type="radio"/>	<input type="radio"/>										

### Parameter Description

<p>&lt;iws&gt;<sup>(num)(&amp;W)(&amp;V)</sup></p> <p>Interworking window size (IWF to MS)</p> <p>0...61<sup>(&amp;F)</sup></p>
<p>&lt;mws&gt;<sup>(num)(&amp;W)(&amp;V)</sup></p> <p>Mobile window size (MS to IWF)</p> <p>0...61<sup>(&amp;F)</sup></p>
<p>&lt;T1&gt;<sup>(num)(&amp;W)(&amp;V)</sup></p> <p>Acknowledgement timer (T1 in 10 ms units)</p> <p>48...[78]<sup>(&amp;F)</sup>...255</p>
<p>&lt;N2&gt;<sup>(num)(&amp;W)(&amp;V)</sup></p> <p>Re-transmission attempts N2</p> <p>1...6<sup>(&amp;F)</sup>...255</p>



## 7.20 AT+CLCC List current calls of ME

The execute command returns a list of current calls of ME. If command is successful, but no calls are available, no information response is sent to TE.

### Syntax

Test Command																	
AT+CLCC=?																	
Response(s)																	
OK																	
Exec Command																	
AT+CLCC																	
Response(s)																	
[+CLCC: <idx>, <dir>, <stat>, <mode>, <empty>[, <number>, <type>[, <alpha>]]]																	
[+CLCC: <idx>, <dir>, <stat>, <mode>, <empty>[, <number>, <type>[, <alpha>]]]																	
[+CLCC: ...]																	
OK																	
ERROR																	
+CME ERROR																	
Reference(s)																	
GSM 07.07																	
	<table border="1"> <tr> <td>PIN</td> <td>ASC0</td> <td>MUX1</td> <td>MUX2</td> <td>MUX3</td> <td>Charge</td> <td></td> <td>Last</td> </tr> <tr> <td>●</td> <td>●</td> <td>●</td> <td>●</td> <td>●</td> <td>○</td> <td>○</td> <td>○</td> </tr> </table>	PIN	ASC0	MUX1	MUX2	MUX3	Charge		Last	●	●	●	●	●	○	○	○
PIN	ASC0	MUX1	MUX2	MUX3	Charge		Last										
●	●	●	●	●	○	○	○										

### Parameter Description

<b>&lt;idx&gt;<sup>(num)</sup></b>	
Call identification number as described in GSM02.30 subclause 4.5.5.1; this number can be used in <a href="#">AT+CHLD</a> command operations	
<b>&lt;dir&gt;<sup>(num)</sup></b>	
0	Mobile originated call (MOC)
1	Mobile terminated call (MTC)
<b>&lt;stat&gt;<sup>(num)</sup></b>	
State of the call	
0	Active
1	Held
2	Dialing (MOC)
3	Alerting (MOC)
4	Incoming (MTC)
5	Waiting (MTC)
<b>&lt;mode&gt;<sup>(num)</sup></b>	
Bearer/teleservice	
0	Voice
1	Data
2	Fax

3	Voice followed by data, voice mode (only in connection with single numbering scheme <a href="#">AT+CSNS</a> )
4	Alternating voice/data, voice mode (only in connection with single numbering scheme <a href="#">AT+CSNS</a> )
5	Alternating voice/fax, voice mode (only in connection with single numbering scheme <a href="#">AT+CSNS</a> )
6	Voice followed by data, data mode (only in connection with single numbering scheme <a href="#">AT+CSNS</a> )
7	Alternating voice/data, data mode (only in connection with single numbering scheme <a href="#">AT+CSNS</a> )
8	Alternating voice/fax, fax mode (only in connection with single numbering scheme <a href="#">AT+CSNS</a> )
9	Unknown

**<mppty><sup>(num)</sup>**

0	Call is not one of multiparty (conference) call parties
1	Call is one of multiparty (conference) call parties

**<number><sup>(str)</sup>**

Phone number in format specified by [<type>](#)

**<type><sup>(num)</sup>**

Type of address octect

145	Dialing string <a href="#">&lt;number&gt;</a> includes international access code character '+'
129	Otherwise

**<alpha><sup>(str)(+CSCS)</sup>**

Alphanumeric representation of [<number>](#) corresponding to the entry found in phonebook; used character set should be the one selected with command [AT+CSCS](#) (Select TE Character Set).

The maximum displayed length of [<alpha>](#) is 16 characters. If [<alpha>](#) has more than 16 characters, only the first 15 characters are displayed. To indicate an overflow, a special character will be used as the 16th character. This is a space if the character set selected with [AT+CSCS](#) is 'GSM', or 'E400' if the character set is 'UCS2'.

Due to time constraints on the necessary evaluation of the phonebook, this parameter may show a default value in early call phases (e.g. for [<stat>](#)= "dialing", "incoming" or "alerting"), even if a phonebook entry is present for the number concerned.

**Note**

- Teleservices other than voice, data, fax are not fully supported by ME. They are used only in connection with the handling for [AT+CSNS](#), and may therefore occur in parameter [<mode>](#) for mobile terminated calls.

## 7.21 AT+CR Service reporting control

AT+CR configures the TA whether or not to transmit an intermediate result code +CR: <serv> to the TE when a call is being set up.

Setting the value of <mode> to 1 may lead to connection failure, if the application (e.g. WinFax) waits for default result code/URC.

The PIN is required for the write command only.

### Syntax

<p>Test Command</p> <p>AT+CR=?</p> <p>Response(s)</p> <p>+CR: (list of supported &lt;mode&gt;s)</p> <p>OK</p> <p>ERROR</p>																	
<p>Read Command</p> <p>AT+CR?</p> <p>Response(s)</p> <p>+CR: &lt;mode&gt;</p> <p>OK</p> <p>ERROR</p>																	
<p>Write Command</p> <p>AT+CR=&lt;mode&gt;</p> <p>Response(s)</p> <p>OK</p> <p>ERROR</p>																	
<p>Reference(s)</p> <p>GSM 07.07</p>	<table border="1"> <tr> <td>PIN</td> <td>ASC0</td> <td>MUX1</td> <td>MUX2</td> <td>MUX3</td> <td>Charge</td> <td></td> <td>Last</td> </tr> <tr> <td><input checked="" type="checkbox"/></td> <td><input checked="" type="checkbox"/></td> <td><input checked="" type="checkbox"/></td> <td><input type="checkbox"/></td> <td><input type="checkbox"/></td> <td><input type="checkbox"/></td> <td><input type="checkbox"/></td> <td><input type="checkbox"/></td> </tr> </table>	PIN	ASC0	MUX1	MUX2	MUX3	Charge		Last	<input checked="" type="checkbox"/>	<input checked="" type="checkbox"/>	<input checked="" type="checkbox"/>	<input type="checkbox"/>	<input type="checkbox"/>	<input type="checkbox"/>	<input type="checkbox"/>	<input type="checkbox"/>
PIN	ASC0	MUX1	MUX2	MUX3	Charge		Last										
<input checked="" type="checkbox"/>	<input checked="" type="checkbox"/>	<input checked="" type="checkbox"/>	<input type="checkbox"/>	<input type="checkbox"/>	<input type="checkbox"/>	<input type="checkbox"/>	<input type="checkbox"/>										

### Intermediate Result Code

If enabled, an intermediate result code is transmitted during connect negotiation when the TA has determined the speed and quality of service to be used, before any error control or data compression reports are transmitted, and before any final result code (e.g. CONNECT) appears.

+CR: <serv>

### Parameter Description

<mode> <sup>(num)(&amp;W)(&amp;V)</sup>	
0(&F)	Disable
1	Enable
<serv> <sup>(str)</sup>	
"REL ASYNC"	Asynchronous non-transparent

## 7.22 AT+CRC Set Cellular Result Codes for incoming call indication

The **AT+CRC** command controls whether or not to use the extended format of incoming call indication. **<mode>=1** may lead to connection failure, if the application (e.g. WinFax) waits for the default URC.

### Syntax

<p>Test Command</p> <p>AT+CRC=?</p> <p>Response(s)</p> <p>+CRC: (list of supported&lt;mode&gt;s)</p> <p>OK</p> <p>ERROR</p>																	
<p>Read Command</p> <p>AT+CRC?</p> <p>Response(s)</p> <p>+CRC: &lt;mode&gt;</p> <p>OK</p> <p>ERROR</p>																	
<p>Write Command</p> <p>AT+CRC=[&lt;mode&gt;]</p> <p>Response(s)</p> <p>OK</p> <p>ERROR</p>																	
<p>Reference(s)</p> <p>GSM 07.07</p>	<table border="1"> <thead> <tr> <th>PIN</th> <th>ASC0</th> <th>MUX1</th> <th>MUX2</th> <th>MUX3</th> <th>Charge</th> <th></th> <th>Last</th> </tr> </thead> <tbody> <tr> <td><input type="radio"/></td> <td><input checked="" type="radio"/></td> <td><input checked="" type="radio"/></td> <td><input checked="" type="radio"/></td> <td><input checked="" type="radio"/></td> <td><input type="radio"/></td> <td><input type="radio"/></td> <td><input type="radio"/></td> </tr> </tbody> </table>	PIN	ASC0	MUX1	MUX2	MUX3	Charge		Last	<input type="radio"/>	<input checked="" type="radio"/>	<input checked="" type="radio"/>	<input checked="" type="radio"/>	<input checked="" type="radio"/>	<input type="radio"/>	<input type="radio"/>	<input type="radio"/>
PIN	ASC0	MUX1	MUX2	MUX3	Charge		Last										
<input type="radio"/>	<input checked="" type="radio"/>	<input checked="" type="radio"/>	<input checked="" type="radio"/>	<input checked="" type="radio"/>	<input type="radio"/>	<input type="radio"/>	<input type="radio"/>										

### Unsolicited Result Codes

URC 1

RING

Indicates incoming call to the TE if **<mode>=0**.

URC 2

+CRING: <type>

Indicates incoming call to the TE if **<mode>=1**.

### Parameter Description

<b>&lt;mode&gt;</b> <sup>(num)(&amp;W)(&amp;V)</sup>	
[0] <sup>(&amp;F)</sup>	Disable extended format
1	Enable extended format
<b>&lt;type&gt;</b> <sup>(str)</sup>	
"REL ASYNC"	Asynchronous non-transparent
"FAX"	Facsimile
"VOICE"	Voice

## 7.23 AT+CSNS Single Numbering Scheme

### Syntax

<p>Test Command</p> <pre>AT+CSNS=?</pre> <p>Response(s)</p> <pre>+CSNS: (list of supported&lt;mode&gt;s) OK</pre>																	
<p>Read Command</p> <pre>AT+CSNS?</pre> <p>Response(s)</p> <pre>+CSNS: &lt;mode&gt; OK</pre>																	
<p>Write Command</p> <pre>AT+CSNS=[&lt;mode&gt;]</pre> <p>Response(s)</p> <pre>OK ERROR +CME ERROR</pre>																	
<p>Reference(s)</p> <pre>GSM 07.07</pre>	<table border="1"> <thead> <tr> <th>PIN</th> <th>ASC0</th> <th>MUX1</th> <th>MUX2</th> <th>MUX3</th> <th>Charge</th> <th></th> <th>Last</th> </tr> </thead> <tbody> <tr> <td><input type="radio"/></td> <td><input checked="" type="radio"/></td> <td><input checked="" type="radio"/></td> <td><input checked="" type="radio"/></td> <td><input checked="" type="radio"/></td> <td><input type="radio"/></td> <td><input type="radio"/></td> <td><input type="radio"/></td> </tr> </tbody> </table>	PIN	ASC0	MUX1	MUX2	MUX3	Charge		Last	<input type="radio"/>	<input checked="" type="radio"/>	<input checked="" type="radio"/>	<input checked="" type="radio"/>	<input checked="" type="radio"/>	<input type="radio"/>	<input type="radio"/>	<input type="radio"/>
PIN	ASC0	MUX1	MUX2	MUX3	Charge		Last										
<input type="radio"/>	<input checked="" type="radio"/>	<input checked="" type="radio"/>	<input checked="" type="radio"/>	<input checked="" type="radio"/>	<input type="radio"/>	<input type="radio"/>	<input type="radio"/>										

### Command Description

The [AT+CSNS](#) command enables the ME to accept incoming calls when no bearer capability information is provided with the call, e.g. single numbering scheme calls or calls originating from analog devices.

### Parameter Description

<mode> <sup>(num)</sup>	
[0] <sup>(D)</sup>	Voice: Each call received without bearer element is assumed to be speech
2	Fax: Each call received without bearer element is assumed to be an incoming fax.
4	Data: Each call received without bearer element is assumed to be a data call. Please take into account that the bearer service parameters set with <a href="#">AT+CBST</a> apply to all data calls including those received without bearer capability.

### Notes

- The command must be set before the call comes. By default, when you do not modify the settings, all calls received without bearer element are assumed to be voice.
- The setting will be automatically saved when you power down the GSM engine with [AT^SMSO](#), provided that PIN authentication has been done. This value will be restored when PIN authentication is done again.

## 7.24 AT^SCNI List Call Number Information

### Syntax

<p>Test Command</p> <pre>AT^SCNI=?</pre> <p>Response(s)</p> <pre>OK</pre>																	
<p>Exec Command</p> <pre>AT^SCNI</pre> <p>Response(s)</p> <pre>^SCNI: &lt;id&gt;_1[,&lt;cs&gt;[,&lt;number&gt;,&lt;type&gt;]] ^SCNI: &lt;id&gt;_2[,&lt;cs&gt;[,&lt;number&gt;,&lt;type&gt;]] [...] OK ERROR +CME ERROR: &lt;err&gt;</pre>																	
<p>Reference(s)</p> <pre>--</pre>	<table border="1"> <tr> <td>PIN</td> <td>ASC0</td> <td>MUX1</td> <td>MUX2</td> <td>MUX3</td> <td>Charge</td> <td></td> <td>Last</td> </tr> <tr> <td><input checked="" type="checkbox"/></td> <td><input checked="" type="checkbox"/></td> <td><input checked="" type="checkbox"/></td> <td><input checked="" type="checkbox"/></td> <td><input checked="" type="checkbox"/></td> <td><input type="checkbox"/></td> <td><input type="checkbox"/></td> <td><input type="checkbox"/></td> </tr> </table>	PIN	ASC0	MUX1	MUX2	MUX3	Charge		Last	<input checked="" type="checkbox"/>	<input checked="" type="checkbox"/>	<input checked="" type="checkbox"/>	<input checked="" type="checkbox"/>	<input checked="" type="checkbox"/>	<input type="checkbox"/>	<input type="checkbox"/>	<input type="checkbox"/>
PIN	ASC0	MUX1	MUX2	MUX3	Charge		Last										
<input checked="" type="checkbox"/>	<input checked="" type="checkbox"/>	<input checked="" type="checkbox"/>	<input checked="" type="checkbox"/>	<input checked="" type="checkbox"/>	<input type="checkbox"/>	<input type="checkbox"/>	<input type="checkbox"/>										

### Command Description

TA returns a list of current calls of ME.

### Parameter Description

<p><b>&lt;id&gt;</b><sup>(num)</sup></p> <p>call identification number as described in GSM 02.30 [19] sub clause 4.5.5.1; this number can be used in <a href="#">AT+CHLD</a> command operations</p> <p>1...7</p>						
<p><b>&lt;cs&gt;</b><sup>(num)</sup></p> <p>Call status of respective call number (first parameter)</p> <table border="0"> <tr> <td>0</td> <td>call hold</td> </tr> <tr> <td>1</td> <td>call in progress</td> </tr> <tr> <td>2</td> <td>waiting call</td> </tr> </table>	0	call hold	1	call in progress	2	waiting call
0	call hold					
1	call in progress					
2	waiting call					
<p><b>&lt;number&gt;</b><sup>(str)</sup></p> <p>string type phone number in format specified by <a href="#">&lt;type&gt;</a></p>						
<p><b>&lt;type&gt;</b><sup>(num)</sup></p> <p>type of address octet in integer format; 145 when dialling string includes international access code character "+", otherwise 129</p>						

### Note

- See also GSM 07.07: [AT+CLCC](#)

## 7.25 AT^SLCD Display Last Call Duration

### Syntax

Test Command	
AT^SLCD=?	
Response(s)	
OK	
ERROR	
+CME ERROR	
Exec Command	
AT^SLCD	
Response(s)	
^SLCD: <time>	
OK	
ERROR	
+CME ERROR	
Reference(s)	
--	
	PIN ASC0 MUX1 MUX2 MUX3 Charge  Last
	● ● ● ● ● ○ ○ ○

### Command Description

TA returns last call duration or current call duration.

### Parameter Description

<time><sup>(str)</sup>

Format is "hh:mm:ss", where characters indicate hours, minutes, seconds; E.g. 22:10:00 "22:10:00"  
Max value is 9999:59:59

### Note

- The proper working of that command is network dependant.

## 7.26 AT^STCD Display Total Call Duration

### Syntax

Test Command							
AT^STCD=?							
Response(s)							
OK							
ERROR							
+CME ERROR							
Exec Command							
AT^STCD							
Response(s)							
^STCD: <time>							
OK							
ERROR							
+CME ERROR							
Reference(s)							
--							
PIN	ASC0	MUX1	MUX2	MUX3	Charge		Last
●	●	●	●	●	○	○	○

### Command Description

TA returns total call duration (accumulated duration of all calls).

### Parameter Description

<time> <sup>(str)</sup>
Format is "hh:mm:ss", where characters indicate hours, minutes, seconds; E.g. 22:10:00 "22:10:00"
Max value is 9999:59:59

### Notes

- The Total Call Duration will not be reset by power off or other means.
- The proper working of that command is network dependant and only for MO calls.



## 7.27 ATP Select pulse dialing

### Syntax

Exec Command								
ATP								
Response(s)								
OK								
Reference(s)	PIN	ASC0	MUX1	MUX2	MUX3	Charge		Last
V.250	<input type="radio"/>	<input checked="" type="radio"/>	<input checked="" type="radio"/>	<input type="radio"/>	<input type="radio"/>	<input type="radio"/>	<input type="radio"/>	<input type="radio"/>

### Note

- No effect for GSM.

## 7.28 ATT Select tone dialing

### Syntax

Exec Command								
ATT								
Response(s)								
OK								
Reference(s)	PIN	ASC0	MUX1	MUX2	MUX3	Charge		Last
V.250	<input type="radio"/>	<input checked="" type="radio"/>	<input checked="" type="radio"/>	<input type="radio"/>	<input type="radio"/>	<input type="radio"/>	<input type="radio"/>	<input type="radio"/>

### Note

- No effect for GSM.

## 8. Network Service Commands

The AT Commands described in this chapter are related to various network services. More commands related to this area can be found in Chapter 9., [Supplementary Service Commands](#).

### 8.1 AT+COPN Read operator names

The [AT+COPN](#) command returns the list of operator names from the ME. Each operator code [<numericn>](#) that has an alphanumeric equivalent [<alphan>](#) in the ME memory is returned. See also: [AT^SPLM](#).

#### Syntax

```
Test Command
AT+COPN=?
Response(s)
OK
ERROR
+CME ERROR

Exec Command
AT+COPN
Response(s)
+COPN: <numericn>, <alphan>
+COPN: ...
OK
ERROR
+CME ERROR

Reference(s)
GSM 07.07
```

PIN	ASC0	MUX1	MUX2	MUX3	Charge		Last
<input checked="" type="radio"/>	<input checked="" type="radio"/>	<input checked="" type="radio"/>	<input checked="" type="radio"/>	<input checked="" type="radio"/>	<input type="radio"/>	<input type="radio"/>	<input type="radio"/>

#### Parameter Description

[<numericn>](#)<sup>(str)</sup>

Operator in numeric format; GSM location area identification number.

[<alphan>](#)<sup>(str)</sup>

Operator in long alphanumeric format; can contain up to 16 characters.

## 8.2 AT+COPS Operator Selection

**AT+COPS** queries the present status of the TC35i's network registration and allows to determine whether automatic or manual network selection shall be used.

Three operator selection modes are available:

- **Automatic**  
TC35i searches for the home operator automatically. If successful the TC35i registers to the home network. If the home network is not found, TC35i goes on searching. If a permitted operator is found, TC35i registers to this operator.  
If no operator is found the TC35i remains unregistered.
- **Manual**  
Desired operator can be determined using the **AT+COPS** write command. If the operator is found, TC35i registers to it immediately. If the selected operator is forbidden, the TC35i remains unregistered.
- **Manual/automatic**  
The ME first tries to find the operator determined via **AT+COPS** write command. If the ME fails to register to this operator, then it starts to select another (permitted) operator automatically.

The **AT+COPS** test command lists sets of four parameters, each representing an operator present in the network. A set consists of

- an integer indicating the availability of the operator,
- long alphanumeric format of the operator's name and
- numeric format representation of the operator.

Any of the parameters may be unavailable and will then be an empty field (,). The list of operators comes in the following order: Home network, networks referenced in SIM and other networks.

The operator list is followed by a list of the supported **<mode>**s and **<format>**s. These lists are delimited from the operator list by two commas.

The **AT+COPS** read command returns the current **<mode>** and the currently selected operator. If no operator is selected, **<format>** and **<oper>** are omitted.

The **AT+COPS** write command forces an attempt to select and register to the GSM network operator (see note below). If the selected operator is not available, no other operator will be selected (except **<mode>=4**). The selected operator name **<format>** will apply to further read commands, too.

Command settings are effective over all serial interfaces of the TC35i.

### Syntax

Test Command

```
AT+COPS=?
```

Response(s)

```
+COPS: [list of present operators (<opStatus>, long alphanumeric <oper>s, numeric <oper>s ], , (list of supported <mode>s), (list of supported <format>s)
```

```
OK
```

```
ERROR
```

```
+CME ERROR: <err>
```

Read Command

```
AT+COPS?
```

Response(s)

```
+COPS: <mode>[, <format>[, <oper>]]
```

```
OK
```

```
ERROR
```

```
+CME ERROR: <err>
```

Write Command

```
AT+COPS=<mode>[, <format>[, <oper>]]
```

Response(s)

```
OK
ERROR
+CME ERROR: <err>
```

Reference(s)

GSM 07.07

PIN	ASC0	MUX1	MUX2	MUX3	Charge	🔔	Last
🔒	●	●	●	●	○	○	○

### Parameter Description

**<opStatus><sup>(num)</sup>**

#### Status

0	Unknown
1	Operator available
2	Current operator
3	Operator forbidden

**<oper><sup>(str)</sup>**

#### Operator

If test command: Operator name in long alphanumeric format and numeric format.  
If read command: Operator name as per **<format>**.  
If write command: Operator name in numeric format.

**<mode><sup>(num)&(V)</sup>**

Parameter values 0 and 1 are stored non-volatile in the TC35i.

0 <sup>(D)</sup>	Automatic mode; <b>&lt;oper&gt;</b> field is ignored.
1	Manual operator selection Write command requires <b>&lt;oper&gt;</b> in numeric format, i.e. <b>&lt;format&gt;</b> shall be 2. Read command returns the current <b>&lt;mode&gt;</b> and the currently selected <b>&lt;oper&gt;</b> . If no operator is selected, <b>&lt;format&gt;</b> and <b>&lt;oper&gt;</b> are omitted.
2	Manually deregister from network and remain unregistered until <b>&lt;mode&gt;</b> =0 or 1 or 4 is selected.
3	Set only <b>&lt;format&gt;</b> (for <b>AT+COPS</b> read command).
4	Automatic / manual selection; if manual selection fails, automatic mode ( <b>&lt;mode&gt;</b> =0) is entered ( <b>&lt;oper&gt;</b> field will be present).

**<format><sup>(num)&(W)&(V)</sup>**

0 <sup>(&amp;F)</sup>	Long alphanumeric format of <b>&lt;oper&gt;</b> . Can be up to 16 characters long.
2	Numeric format of <b>&lt;oper&gt;</b> . This is the GSM Location Area Identification (LAI) number, which consists of the 3-digit Mobile Country Code (MCC) plus the 2- or 3-digit Mobile Network Code (MNC).

---

**Note**

- It is not recommended to use the [AT+COPS](#) command before passing the CHV (card holder verification) / SIM PIN1 verification. This is because after PIN1 verification the module will automatically try to register to the network as though [AT+COPS](#) were 0, regardless of the settings done before with or without SIM, such as [AT+COPS=2](#) which remains unchanged. Also, the test command should only be used after PIN1 authentication.

## 8.3 AT+CREG Network registration

The [AT+CREG](#) command serves to verify the network registration status of the ME. For this purpose two types of URCs are available.

The [AT+CREG](#) read command returns the URC presentation mode `<n>` and an integer `<stat>` that shows the registration status of the ME. The location information elements `<lac>` and `<ci>` are returned only when `<n>=2` and ME is registered to the network.

### Syntax

<p>Test Command</p> <pre>AT+CREG=?</pre> <p>Response(s)</p> <pre>+CREG: (list of supported&lt;n&gt;s) OK</pre>																	
<p>Read Command</p> <pre>AT+CREG?</pre> <p>Response(s)</p> <pre>+CREG: &lt;n&gt;, &lt;stat&gt;[, &lt;lac&gt;, &lt;ci&gt;] OK ERROR +CME ERROR: &lt;err&gt;</pre>																	
<p>Write Command</p> <pre>AT+CREG=[&lt;n&gt;]</pre> <p>Response(s)</p> <pre>OK ERROR +CME ERROR: &lt;err&gt;</pre>																	
<p>Reference(s)</p> <pre>GSM 07.07</pre>	<table border="1"> <tr> <td>PIN</td> <td>ASC0</td> <td>MUX1</td> <td>MUX2</td> <td>MUX3</td> <td>Charge</td> <td></td> <td>Last</td> </tr> <tr> <td><input type="radio"/></td> <td><input checked="" type="radio"/></td> <td><input checked="" type="radio"/></td> <td><input checked="" type="radio"/></td> <td><input checked="" type="radio"/></td> <td><input type="radio"/></td> <td><input type="radio"/></td> <td><input type="radio"/></td> </tr> </table>	PIN	ASC0	MUX1	MUX2	MUX3	Charge		Last	<input type="radio"/>	<input checked="" type="radio"/>	<input checked="" type="radio"/>	<input checked="" type="radio"/>	<input checked="" type="radio"/>	<input type="radio"/>	<input type="radio"/>	<input type="radio"/>
PIN	ASC0	MUX1	MUX2	MUX3	Charge		Last										
<input type="radio"/>	<input checked="" type="radio"/>	<input checked="" type="radio"/>	<input checked="" type="radio"/>	<input checked="" type="radio"/>	<input type="radio"/>	<input type="radio"/>	<input type="radio"/>										

### Unsolicited Result Codes

#### URC 1

If `<n>=1` and there is a change in the ME network registration status:

```
+CREG: <stat>
```

#### URC 2

If `<n>=2` and there is a change in the ME network registration status or a change of the network cell:

```
+CREG: <stat>[, <lac>, <ci>]
```

### Parameter Description

<code>&lt;n&gt;</code> <sup>(num)(&amp;W)(&amp;V)</sup>	Description
<code>[0]</code> <sup>(&amp;F)</sup>	Disable +CREG URC
1	Enable URC +CREG: <code>&lt;stat&gt;</code> to report status of network registration
2	Enable URC +CREG: <code>&lt;stat&gt;[, &lt;lac&gt;, &lt;ci&gt;]</code> to report status of network registration including location information. Optional parameters <code>&lt;lac&gt;</code> and <code>&lt;ci&gt;</code> will not be displayed during calls or if these values have not changed since last <a href="#">AT+CREG</a> read command or since last indication by +CREG URC.

<stat>^(num)&V)

0	<p>Not registered, ME is currently not searching for new operator There is a technical problem. User intervention is required. Yet, emergency calls can be made if any network is available. Probable causes:</p> <ul style="list-style-type: none"><li>• no SIM card available</li><li>• no PIN entered</li><li>• no valid Home PLMN entry found on the SIM</li></ul>
1	<p>Registered to home network</p>
2	<p>Not registered, but ME is currently searching for a new operator The ME searches for an available network. Failure to log in until after more than a minute may be due to one of the following reasons:</p> <ul style="list-style-type: none"><li>• No network available or insufficient Rx level.</li><li>• The ME has no access rights to the networks available.</li><li>• Networks from the SIM list of allowed networks are around, but login fails due to one of the following reasons:<ul style="list-style-type: none"><li>- #11 ... PLMN not allowed</li><li>- #12 ... Location area not allowed</li><li>- #13 ... Roaming not allowed in this location area</li></ul></li></ul> <p>After this, the search will be resumed (if automatic network search is enabled).</p> <ul style="list-style-type: none"><li>• The Home PLMN or an allowed PLMN is available, but login is rejected by the cell (reasons: Access Class or LAC).</li></ul> <p>If at least one network is available, emergency calls can be made.</p>
3	<p>Registration denied</p> <ul style="list-style-type: none"><li>• If automatic network search is enabled: Authentication or registration fails after Location Update Reject due to one of the following reasons:<ul style="list-style-type: none"><li>- #2 ... IMSI unknown at HLR</li><li>- #3 ... Illegal MS</li><li>- #6 ... Illegal ME</li></ul></li></ul> <p>Either the SIM or the MS or the ME are unable to log into any network. User intervention is required. Emergency calls can be made, if any network is available.</p> <ul style="list-style-type: none"><li>• Only if manual network search is enabled: Manual registration fails after Location Update Reject due to the following reasons:<ul style="list-style-type: none"><li>- #2 ... IMSI unknown at HLR</li><li>- #3 ... Illegal MS</li><li>- #6 ... Illegal ME</li><li>- #11 ... PLMN not allowed</li><li>- #12 ... Location area not allowed</li><li>- #13 ... Roaming not allowed in this location area</li></ul></li></ul> <p>No further attempt is made to search or log into a network. Emergency calls can be made if any network is available.</p>
4	<p>Unknown (not used)</p>
5	<p>Registered, roaming The ME is registered at a foreign network (national or international network)</p>

<lac><sup>(str)</sup>

Two byte location area code in hexadecimal format (e.g. "00C3" equals 193 in decimal).

<ci><sup>(str)</sup>

Two byte cell ID in hexadecimal format.

### **Example**

AT+CREG=2	Activates extended URC mode.
OK	
AT+COPS=0	Forces ME to automatically search network operator.
OK	
+CREG: 2	URC reports that ME is currently searching.
+CREG: 1, "0145", "291A"	URC reports that operator has been found.



## 8.4 AT+CSQ Signal quality

The [AT+CSQ](#) execute command indicates the received signal strength `<rssi>` and the channel bit error rate `<ber>`.

### Syntax

<p>Test Command</p> <pre>AT+CSQ=?</pre> <p>Response(s)</p> <pre>+CSQ: (list of supported&lt;rssi&gt;s), (list of supported&lt;ber&gt;s) OK</pre>	<p>Exec Command</p> <pre>AT+CSQ</pre> <p>Response(s)</p> <pre>+CSQ: &lt;rssi&gt;,&lt;ber&gt; OK</pre>																
<p>Reference(s)</p> <p>GSM 07.07</p>	<table border="1"> <tr> <td>PIN</td> <td>ASC0</td> <td>MUX1</td> <td>MUX2</td> <td>MUX3</td> <td>Charge</td> <td></td> <td>Last</td> </tr> <tr> <td><input type="radio"/></td> <td><input checked="" type="radio"/></td> <td><input checked="" type="radio"/></td> <td><input checked="" type="radio"/></td> <td><input checked="" type="radio"/></td> <td><input type="radio"/></td> <td><input type="radio"/></td> <td><input type="radio"/></td> </tr> </table>	PIN	ASC0	MUX1	MUX2	MUX3	Charge		Last	<input type="radio"/>	<input checked="" type="radio"/>	<input checked="" type="radio"/>	<input checked="" type="radio"/>	<input checked="" type="radio"/>	<input type="radio"/>	<input type="radio"/>	<input type="radio"/>
PIN	ASC0	MUX1	MUX2	MUX3	Charge		Last										
<input type="radio"/>	<input checked="" type="radio"/>	<input checked="" type="radio"/>	<input checked="" type="radio"/>	<input checked="" type="radio"/>	<input type="radio"/>	<input type="radio"/>	<input type="radio"/>										

### Parameter Description

<code>&lt;rssi&gt;</code> <sup>(num)</sup>	
0	-113 dBm or less
1	-111 dBm
2..30	-109... -53 dBm
31	-51 dBm or greater
99	not known or not detectable

<code>&lt;ber&gt;</code> <sup>(num)</sup>	
0..7	as RXQUAL values in the table in GSM 05.08 section 8.2.4.
99	not known or not detectable

### Note

- After using network related commands such as [AT+CCWA](#), [AT+CCFC](#), [AT+CLCK](#), users are advised to wait 3s before entering [AT+CSQ](#). This is recommended to be sure that any network access required for the preceding command has finished.

## 8.5 AT^SMONC Cell Monitoring

The `AT^SMONC` execute command delivers cell information containing 9 values from a maximum of 7 base stations. The first base station is the serving cell.

### Syntax

<p>Test Command</p> <p>AT^SMONC=?</p> <p>Response(s)</p> <p>OK</p> <p>ERROR</p> <p>+CME ERROR</p>																	
<p>Exec Command</p> <p>AT^SMONC</p> <p>Response(s)</p> <p>^SMONC: &lt;MCC&gt;<sub>1</sub>, &lt;MNC&gt;<sub>1</sub>, &lt;LAC&gt;<sub>1</sub>, &lt;cell&gt;<sub>1</sub>, &lt;BSIC&gt;<sub>1</sub>, &lt;chann&gt;<sub>1</sub>, &lt;RSSI&gt;<sub>1</sub>, &lt;C1&gt;<sub>1</sub>, &lt;C2&gt;<sub>1</sub>, &lt;MCC&gt;<sub>2</sub>, &lt;MNC&gt;<sub>2</sub>, &lt;LAC&gt;<sub>2</sub>, &lt;cell&gt;<sub>2</sub>, &lt;BSIC&gt;<sub>2</sub>, &lt;chann&gt;<sub>2</sub>, &lt;RSSI&gt;<sub>2</sub>, &lt;C1&gt;<sub>2</sub>, &lt;C2&gt;<sub>2</sub>, ...</p> <p>OK</p> <p>ERROR</p> <p>+CME ERROR</p>																	
<p>Reference(s)</p> <p>3GPP TS 05.08</p>	<table border="1"> <tr> <th>PIN</th> <th>ASC0</th> <th>MUX1</th> <th>MUX2</th> <th>MUX3</th> <th>Charge</th> <th></th> <th>Last</th> </tr> <tr> <td><input checked="" type="checkbox"/></td> <td><input checked="" type="checkbox"/></td> <td><input checked="" type="checkbox"/></td> <td><input checked="" type="checkbox"/></td> <td><input checked="" type="checkbox"/></td> <td><input type="checkbox"/></td> <td><input type="checkbox"/></td> <td><input type="checkbox"/></td> </tr> </table>	PIN	ASC0	MUX1	MUX2	MUX3	Charge		Last	<input checked="" type="checkbox"/>	<input checked="" type="checkbox"/>	<input checked="" type="checkbox"/>	<input checked="" type="checkbox"/>	<input checked="" type="checkbox"/>	<input type="checkbox"/>	<input type="checkbox"/>	<input type="checkbox"/>
PIN	ASC0	MUX1	MUX2	MUX3	Charge		Last										
<input checked="" type="checkbox"/>	<input checked="" type="checkbox"/>	<input checked="" type="checkbox"/>	<input checked="" type="checkbox"/>	<input checked="" type="checkbox"/>	<input type="checkbox"/>	<input type="checkbox"/>	<input type="checkbox"/>										

### Parameter Description

<code>&lt;MCC&gt;</code> <sup>(num)</sup>	
Mobile country code	
3 digits, e.g. 232	
000	Not decoded
<code>&lt;MNC&gt;</code> <sup>(num)</sup>	
Mobile network code	
2 digits or 3 digits, e.g. 07 or 003	
000	Not decoded
<code>&lt;LAC&gt;</code> <sup>(num)</sup>	
Location area code	
4 hexadecimal digits, e.g. 4EED	
0000	Not decoded
<code>&lt;cell&gt;</code> <sup>(num)</sup>	
Cell identifier	
4 hexadecimal digits, e.g. 4EAF	
0000	Not decoded



## 8.6 AT^SMOND Cell Monitoring

The `AT^SMOND` write command can be used to obtain selected cell information automatically every `<period>` seconds. The cell or set of cells to be examined and the information to be retrieved can be specified by means of the parameter `<format>`.

Output will pause for the specified number of seconds after each output line. To stop the presentation type "AT" or "at".

The execute command returns, on request, the full amount of cell information obtained when using the write command with `<format>= 15`.

### Syntax

<p>Test Command</p> <pre>AT^SMOND=?</pre> <p>Response(s)</p> <pre>^SMOND: (list of supported &lt;period&gt;s), (list of supported &lt;format&gt;s) OK ERROR +CME ERROR</pre>	
<p>Exec Command</p> <pre>AT^SMOND</pre> <p>Response(s)</p> <pre>^SMOND: [&lt;sci&gt;][, &lt;nci&gt;][, &lt;TA&gt;][, &lt;rssiber&gt;] OK ERROR +CME ERROR</pre>	
<p>Write Command</p> <pre>AT^SMOND=&lt;period&gt;[, &lt;format&gt;]</pre> <p>Response(s)</p> <pre>^SMOND: &lt;celldata&gt; ^SMOND: &lt;celldata&gt; [^SMOND: ...] OK ERROR +CME ERROR</pre>	
<p>Reference(s)</p> <p>3GPP TS 05.08</p>	

### Parameter Description

`<format>`<sup>(num)</sup>

Integer or sum of integers each representing a class of requested information, i.e. a group of output values. Parameter format can be determined by summing up the values for each of the requested classes of information. The possible values and their associated information are listed below. Value 0 is not allowed. The default value and the maximum value are 15, representing the sum of all possible class values, leading to the output of all available information.

- |   |   |
|---|---|
| 1 | Include <code>&lt;sci&gt;</code> in response string <code>&lt;celldata&gt;</code>     |
| 2 | Include <code>&lt;nci&gt;</code> in response string <code>&lt;celldata&gt;</code>     |
| 4 | Include <code>&lt;TA&gt;</code> in response string <code>&lt;celldata&gt;</code>      |
| 8 | Include <code>&lt;rssiber&gt;</code> in response string <code>&lt;celldata&gt;</code> |

`<period>`<sup>(num)</sup>

display period

1...254

Display period in seconds, i.e. the period to wait before the next output of `<celldata>`.

`<celldata>`<sup>(str)</sup>

A list of values describing the current radio environment of the module. The information to be included in the response string can be selected using parameter `<format>`. All values are comma-separated with no `<CR>` or `<LF>` included in the response string.

possible groups of information are (in order of output): `<sci>`, `<nci>`, `<TA>` and `<rssiber>`.

`<sci>`<sup>(str)</sup>

Serving cell information (comma-separated, no cr/lf included)

`<MCC>`,`<MNC>`,`<LAC>`,`<cell>`,`<BSIC>`,`<chann>`,`<RxLev>`,`<RxLev>Full`,`<RxLev>Sub`,`<RxQual>`,`<RxQual>Full`,`<RxQual>Sub`,`<Timeslot>`

If no serving cell is found, unavailable values are omitted: " ,,,,,,`<RxLev>`,,,0,,0"

`<nci>`<sup>(str)</sup>

Neighbour cell information for neighbour cell 1 through 6 (comma-separated, no cr/lf included)

`<MCC>`<sub>1</sub>,`<MNC>`<sub>1</sub>,`<LAC>`<sub>1</sub>,`<cell>`<sub>1</sub>,`<BSIC>`<sub>1</sub>,`<chann>`<sub>1</sub>,`<RxLev>`<sub>1</sub>, (these parameters repeated for neighbour cells 2 through 6 with no CR/LF): ... `<MCC>`<sub>6</sub>,`<MNC>`<sub>6</sub>,`<LAC>`<sub>6</sub>,`<cell>`<sub>6</sub>,`<BSIC>`<sub>6</sub>,`<chann>`<sub>6</sub>,`<RxLev>`<sub>6</sub>

An unavailable cell appears as follows: " ,,,,,,0"

`<rssiber>`<sup>(str)</sup>

Values for RSSI and BER (comma-separated, no cr/lf included)

`<RSSI>`,`<BER>`

`<MCC>`<sup>(num)</sup>

Mobile country code

3 digits, e.g. 232

000

Not decoded

`<MNC>`<sup>(num)</sup>

Mobile network code

2 digits or 3 digits, e.g. 07 or 003

000

Not decoded

`<LAC>`<sup>(num)</sup>

Location area code

4 hexadecimal digits, e.g. 4EED

0000

Not decoded

`<cell>`<sup>(num)</sup>

Cell identifier

4 hexadecimal digits, e.g. 4EAF

0000

Not decoded



- Parameter sets not requested with input parameter `<format>` will be left out altogether. For example, the response for `<format>= 12` will read:  
^SMOND:<TA>,<RSSI>,<BER>  
OK
- For compatibility with earlier products and to support legacy applications, often any input character will stop the periodic output of the write command. But since this applies only in certain cases (depending on the settings of Section 4.10, AT+IPR and Section 4.11, AT+CMUX), it is recommended to always use "at" or "AT".

### Examples

#### EXAMPLE 1

```
at^smond                               Execute command
^SMOND:262,01,3008,6060,32,100,66,,,0,,,0 Line breaks inserted for readability in print
,
262,01,3008,DDD1,35,92,80,
262,01,3008,,31,96,83,
262,01,3008,BFBE,35,27,86,
262,01,3008,,32,98,88,
262,01,3008,BB44,32,90,89,
262,01,3008,8307,31,22,93,
2,23,99
```

#### EXAMPLE 2

```
at^smond=1                               write command <period>= 1: wait 1 second
                                         between consecutive output lines.
                                         <format> is assumed 15 (full output) by default
^SMOND:262,01,3008,6060,32,100,66,,,0,,,0 (Line breaks inserted for readability in print)
,
262,01,3008,DDD1,35,92,80,
262,01,3008,,31,96,81,
262,01,3008,BFBE,35,27,85,
262,01,3008,,32,98,87,
262,01,3008,BB44,32,90,87,
262,01,3008,8307,31,22,93,
2,23,99

                                         Wait 15s for next output line
^SMOND:262,01,3008,6060,32,100,66,,,0,,,0 (Line breaks inserted for readability in print)
,
262,01,3008,DDD1,35,92,81,
262,01,3008,,31,96,83,
262,01,3008,BFBE,35,27,84,
262,01,3008,,32,98,87,
262,01,3008,BB44,32,90,91,
262,01,3008,8307,31,22,93,
2,23,99

                                         Wait 15s for next output line
^SMOND:262,01,3008,6060,32,100,67,,,0,,,0 (Line breaks inserted for readability in print)
,
262,01,3008,DDD1,35,92,81,
262,01,3008,,31,96,82,
262,01,3008,BFBE,35,27,85,
262,01,3008,,32,98,89,
262,01,3008,BB44,32,90,91,
262,01,3008,8307,31,22,93,
2,23,99

                                         stop the output by sending a character over the serial
                                         interface
OK                                         write command terminated successfully
```

```
at^smond=240,5
```

```
^SMOND:262,01,3008,6060,32,100,68,,,0,,0  
,2
```

```
OK
```

<period>= 240 Wait 4 minutes before the output of each new line.

<format>= 5 indicates only serving cell information <sci> and Timing Advance <TA> are requested.

stop the output by sending a character over the serial interface

write command terminated successfully



## 8.7 AT^MONI Monitor idle mode and dedicated mode

The [AT^MONI](#) command supplies information of the serving/dedicated cell. There are two ways to retrieve the information: once on request by using the execute command or automatically every `<period>` seconds by using the write command. To stop the periodic presentation type "AT" or "at".

### Syntax

<p>Test Command</p> <pre>AT^MONI=?</pre> <p>Response(s)</p> <pre>^MONI : (list of supported &lt;period&gt;s) OK</pre>																	
<p>Exec Command</p> <pre>AT^MONI</pre> <p>Response(s)</p> <p>See: Section 8.7.1, <a href="#">AT^MONI responses</a></p> <pre>OK</pre>																	
<p>Write Command</p> <pre>AT^MONI=&lt;period&gt;</pre> <p>Response(s)</p> <p>See: Section 8.7.1, <a href="#">AT^MONI responses</a></p> <pre>OK ERROR +CME ERROR</pre>																	
<p>Reference(s)</p> <pre>--</pre>	<table border="1"> <tr> <td>PIN</td> <td>ASC0</td> <td>MUX1</td> <td>MUX2</td> <td>MUX3</td> <td>Charge</td> <td></td> <td>Last</td> </tr> <tr> <td>○</td> <td>●</td> <td>●</td> <td>●</td> <td>●</td> <td>○</td> <td>○</td> <td>○</td> </tr> </table>	PIN	ASC0	MUX1	MUX2	MUX3	Charge		Last	○	●	●	●	●	○	○	○
PIN	ASC0	MUX1	MUX2	MUX3	Charge		Last										
○	●	●	●	●	○	○	○										

### Parameter Description

<code>&lt;period&gt;</code> <sup>(num)</sup>
Display period in seconds
1...254

### Notes

- The two header lines (see Section 8.7.1, [AT^MONI responses](#)) are output after every ten data lines.
- The length of following output lines exceeds 80 characters. Therefore a terminal program may draw a carriage return on a screen. However, this is not part of the response.
- The parameters LAC and cell are presented as hexadecimal digits, the remaining parameters are composed of decimal digits.
- If the radio cell changes during a connection, the parameters PWR, RXLev and C1 of the 'Serving Cell' part cannot be updated under certain conditions and therefore, are displayed as "-" (for conditions see also [AT+CREG](#)). This is because the MS does not update the cell selection and reselection parameters since, in this mode, they are not relevant for operation. When the connection ends, and the mobile is back to IDLE mode, correct values will be given.  
If the radio cell changes during a connection, it normally takes 1 or 2 seconds to update the parameters cell, NCC and BCC. Until the information is received from the new base station, the default values will be shown instead: cell="0000", NCC="-", BCC="-".
- If the BS supports frequency hopping during a connection, the dedicated channel (parameter chann) is not stable. This mode is indicated by chann = 'h'.

- To some extent, the cell monitoring command `AT^SMONC` covers the same parameters. The receiving level, for example, can be queried with both commands. Yet the resulting values may be slightly different, even though obtained over a time period of a few seconds. This is quite normal and nothing to worry about, as the cell information is permanently updated.
- For compatibility with earlier products and to support legacy applications, any input character may be used to stop the output in certain cases (depending on the settings of `AT+IPR` and `AT+CMUX`).

### 8.7.1 AT^MONI responses

ME is not connected:

a) ME is camping on a cell and registered to the network:

Serving Cell															I Dedicated channel				
chann	rs	dBm	MCC	MNC	LAC	cell	NCC	BCC	PWR	RXLev	C1	I	chann	TS	timAdv	PWR	dBm	Q	ChMod
1013	21	-71	001	01	1001	0103	7	7	33	-105	33	I	No	connection					

b) ME is camping on a cell but not registered to the network (only emergency call allowed):

Serving Cell															I Dedicated channel				
chann	rs	dBm	MCC	MNC	LAC	cell	NCC	BCC	PWR	RXLev	C1	I	chann	TS	timAdv	PWR	dBm	Q	ChMod
1013	21	-71	001	01	1001	0103	7	7	33	-105	33	I	Limited	Service					

c) ME camping on a cell, but searching for a better cell (cell reselection):

Serving Cell															I Dedicated channel				
chann	rs	dBm	MCC	MNC	LAC	cell	NCC	BCC	PWR	RXLev	C1	I	chann	TS	timAdv	PWR	dBm	Q	ChMod
1013	21	-71	001	01	1001	0103	7	7	33	-105	33	I	Cell	Reselection					

d) ME is searching and could not (yet) find a suitable cell:

Serving Cell															I Dedicated channel				
chann	rs	dBm	MCC	MNC	LAC	cell	NCC	BCC	PWR	RXLev	C1	I	chann	TS	timAdv	PWR	dBm	Q	ChMod
Searching																			

ME is connected (Call in progress):

Serving Cell															I Dedicated channel				
chann	rs	dBm	MCC	MNC	LAC	cell	NCC	BCC	PWR	RXLev	C1	I	chann	TS	timAdv	PWR	dBm	Q	ChMod
1013	19	-76	001	01	1001	0103	7	7	33	-105	33	I	1015	1	0	5	-76	0	S_HR

Columns for Serving Cell:

Column	Description
chann	ARFCN (Absolute Frequency Channel Number) of the BCCH carrier
rs	RSSI value 0 - 63 (RSSI = Received signal strength indication)
dBm	Receiving level of the BCCH carrier in dBm
MCC	Mobile Country Code (first part of the PLMN code)
MNC	Mobile Network Code (second part of the PLMN code)
LAC	Location area code, see note below
cell	Cell ID
NCC	PLMN colour code
BCC	Base station colour code
PWR	Maximal power level used on RACH channel in dBm

Column	Description
RXLev	Minimal receiving level (in dBm) to allow registration
C1	Coefficient for base station selection

Columns for Dedicated channel:

Column	Description
chann	ARFCN (Absolute Frequency Channel Number) of the TCH carrier Note: <chann> = h indicates frequency hopping.
TS	Timeslot number
timAdv	Timing advance in bits
PWR	Current power level
dBm	Receiving level of the traffic channel carrier in dBm
Q	Receiving quality (0-7)
ChMod	Channel mode (S_HR: Half rate, S_FR: Full rate, S_EFR: Enhanced Full Rate)

## 8.7.2 Service states

Depending on the service state, an additional textual output is generated (refer also to the response examples):

- 'Searching' - The MS is searching, but could not (yet) find a suitable cell. This output appears after restart of the MS or after loss of coverage.
- 'No connection' - The MS is camping on a cell and registered to the network. The service state is 'idle', i.e. there is no connection established or a dedicated channel in use.
- 'Cell Reselection' - The MS has not yet lost coverage but is searching for a better cell, since the cell reselection criterion is fulfilled.
- 'Limited Service' - The MS is camping on a cell but not registered to the network. Only emergency calls are allowed. The MS enters this state, for example, when
  - no SIM card is inserted, or PIN has not been given,
  - neither Home PLMN nor any other allowed PLMN are found,
  - registration request was not answered or denied by the network (use command AT+CREG to query the registration status),
  - authentication failed.

## 8.8 AT^MONP Monitor neighbour cells

The [AT^MONP](#) supplies information of up to six neighbour cells. There are two ways to retrieve the information: once on request by using the execute command or automatically every `<period>` seconds by using the write command. To stop the periodic presentation type "AT" or "at".

### Syntax

<p>Test Command</p> <p>AT^MONP=?</p> <p>Response(s)</p> <p>^MONP : (list of supported <code>&lt;period&gt;</code>s)</p> <p>OK</p>																	
<p>Exec Command</p> <p>AT^MONP</p> <p>Response(s)</p> <p>See: Section 8.8.1, <a href="#">AT^MONP responses</a></p> <p>OK</p>																	
<p>Write Command</p> <p>AT^MONP=<code>&lt;period&gt;</code></p> <p>Response(s)</p> <p>See: Section 8.8.1, <a href="#">AT^MONP responses</a></p> <p>OK</p> <p>ERROR</p> <p>+CME ERROR</p>																	
<p>Reference(s)</p> <p>--</p>	<table border="1"> <thead> <tr> <th>PIN</th> <th>ASC0</th> <th>MUX1</th> <th>MUX2</th> <th>MUX3</th> <th>Charge</th> <th></th> <th>Last</th> </tr> </thead> <tbody> <tr> <td>○</td> <td>●</td> <td>●</td> <td>●</td> <td>●</td> <td>○</td> <td>○</td> <td>○</td> </tr> </tbody> </table>	PIN	ASC0	MUX1	MUX2	MUX3	Charge		Last	○	●	●	●	●	○	○	○
PIN	ASC0	MUX1	MUX2	MUX3	Charge		Last										
○	●	●	●	●	○	○	○										

### Parameter Description

<code>&lt;period&gt;</code> <sup>(num)</sup>
Display period in seconds
1...254

### Notes

- Due to the fact that not all necessary information of the neighbour cells can be decoded during a connection, there are several constraints to be considered:
  - Only neighbour cells that have already been visible in IDLE mode will be further updated, as long as they are still included in the list.
  - Though new neighbour cells can be added to the list (e.g. due to handover), their C1 and C2 parameters cannot be displayed until the connection is released. In this case "-" is presented for C1 and C2.
  - To some extent, the cell monitoring command [AT^SMONC](#) covers the same parameters. The receiving level, for example, can be queried with both commands. Yet the resulting values may be slightly different, even though obtained over a time period of a few seconds. This is quite normal and nothing to worry about, as the cell information is permanently updated.
- For compatibility with earlier products and to support legacy applications, any input character may be used to stop the output in certain cases (depending on the settings of [AT+IPR](#) and [AT+CMUX](#)).

## 8.8.1 AT^MONP responses

Response of AT^MONP (Example):

chann	rs	dBm	MCC	MNC	BCC	C1	C2
653	26	-84	262	07	0	22	22
660	20	-90	262	07	3	16	16
687	19	-91	262	07	1	15	15
678	14	-96	262	07	3	10	10
671	14	-96	262	07	1	10	10
643	10	-100	262	07	7	6	6

Column	Description
Chann	ARFCN (Absolute Radio Frequency Channel Number) of the BCCH carrier
rs	RSSI value 0 - 63 (RSSI = Received signal strength indication)
dBm	Receiving level in dBm
MCC	Mobile Country Code (first part of the PLMN code)
MNC	Mobile Network Code (second part of the PLMN code)
BCC	Base Station colour code
C1	cell selection criterion
C2	cell reselection criterion

## 8.9 AT^SALS Alternate Line Service

The `AT^SALS` command is designed to support Alternate Line Service. This allows the subscriber to use two voice numbers on the same SIM card (service requires a dual line SIM card).

The write command enables or disables the presentation of `<view>` and specifies the `<line>` used for outgoing calls. The read command returns the presentation mode of `<view>` and the currently selected `<line>`.

### Syntax

<p>Test Command</p> <pre>AT^SALS=?</pre> <p>Response(s)</p> <pre>^SALS: (list of supported &lt;view&gt;s), (list of supported &lt;line&gt;s) OK</pre>																	
<p>Read Command</p> <pre>AT^SALS?</pre> <p>Response(s)</p> <pre>^SALS: &lt;view&gt;, &lt;line&gt; OK ERROR</pre>																	
<p>Write Command</p> <pre>AT^SALS=&lt;view&gt;[, &lt;line&gt;]</pre> <p>Response(s)</p> <pre>OK ERROR</pre>																	
<p>Reference(s)</p> <pre>--</pre>	<table border="1"> <tr> <td>PIN</td> <td>ASC0</td> <td>MUX1</td> <td>MUX2</td> <td>MUX3</td> <td>Charge</td> <td></td> <td>Last</td> </tr> <tr> <td><input checked="" type="checkbox"/></td> <td><input checked="" type="checkbox"/></td> <td><input checked="" type="checkbox"/></td> <td><input checked="" type="checkbox"/></td> <td><input checked="" type="checkbox"/></td> <td><input type="checkbox"/></td> <td><input type="checkbox"/></td> <td><input type="checkbox"/></td> </tr> </table>	PIN	ASC0	MUX1	MUX2	MUX3	Charge		Last	<input checked="" type="checkbox"/>	<input checked="" type="checkbox"/>	<input checked="" type="checkbox"/>	<input checked="" type="checkbox"/>	<input checked="" type="checkbox"/>	<input type="checkbox"/>	<input type="checkbox"/>	<input type="checkbox"/>
PIN	ASC0	MUX1	MUX2	MUX3	Charge		Last										
<input checked="" type="checkbox"/>	<input checked="" type="checkbox"/>	<input checked="" type="checkbox"/>	<input checked="" type="checkbox"/>	<input checked="" type="checkbox"/>	<input type="checkbox"/>	<input type="checkbox"/>	<input type="checkbox"/>										

### Unsolicited Result Code

If switched on with `<view>=1`:

```
^SALS: <line>
```

Indicates the line used by an incoming call.

### Parameter Description

<code>&lt;view&gt;</code> <sup>(num)</sup>	
Controls the presentation mode of the URC " <code>^SALS</code> " which indicates the line number used by an incoming call:	
<code>0</code> <sup>(&amp;F)(P)</sup>	Disables indication of the called line
<code>1</code>	Enables indication of the called line
<code>&lt;line&gt;</code> <sup>(num)</sup>	
Selects the line to be used for outgoing calls. Setting is global for the ME and non volatile.	
<code>1</code> <sup>(&amp;F)(D)</sup>	ALS Line 1
<code>2</code>	ALS Line 2

### Note

- If a non ALS SIM is inserted, the `<line>` will be reset to line 1.

---

**Example**

```
AT^SALS=1,1  
RING  
^SALS: 2
```

Line 1 has been selected for outgoing calls. "^SALS" URC is enabled.  
You receive a notification that you have an incoming call on line 2.

## 8.10 AT^SHOM Display Homezone

The `AT^SHOM` returns the homezone state. The result is valid only, if network registration state `<stat>` is 1 (registered) (see `AT+CREG`).

The feature is available only for supported network operators (Viag, One2One, Orange and LCI) and requires a suitable SIM card. If the homezone feature is not supported by the network operator or SIM card, result is always 0.

### Syntax

Test Command	AT^SHOM=?
Response(s)	OK
Exec Command	AT^SHOM
Response(s)	^SHOM: <homezonestate> OK ERROR +CME ERROR: <err>
Reference(s)	--

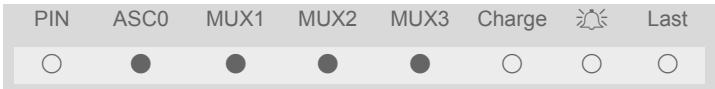

### Parameter Description

<homezonestate> <sup>(num)</sup>	
0	ME is out of Homezone
1	ME is within the Homezone



## 8.11 AT^SPLM Read the PLMN list

The `AT^SPLM` execute command returns the list of operators from the ME. Each operator code `<numeric>` that has an alphanumeric equivalent `<alpha>` in the ME memory is returned. The list is sorted by operator codes. See also GSM 07.07: [AT+COFN](#), [AT+COFS](#)

### Syntax

<p>Test Command</p> <pre>AT^SPLM=?</pre> <p>Response(s)</p> <pre>OK If error is related to ME functionality: ERROR +CME ERROR: &lt;err&gt;</pre>	<p>Exec Command</p> <pre>AT^SPLM</pre> <p>Response(s)</p> <pre>^SPLM: &lt;numeric&gt;, long &lt;alpha&gt; ^SPLM:[... ] OK If error is related to ME functionality: ERROR +CME ERROR</pre>																
<p>Reference(s)</p> <p>GSM 07.07</p>	<table border="1"> <tr> <td>PIN</td> <td>ASC0</td> <td>MUX1</td> <td>MUX2</td> <td>MUX3</td> <td>Charge</td> <td></td> <td>Last</td> </tr> <tr> <td><input checked="" type="checkbox"/></td> <td><input checked="" type="checkbox"/></td> <td><input checked="" type="checkbox"/></td> <td><input checked="" type="checkbox"/></td> <td><input checked="" type="checkbox"/></td> <td><input type="checkbox"/></td> <td><input type="checkbox"/></td> <td><input type="checkbox"/></td> </tr> </table>	PIN	ASC0	MUX1	MUX2	MUX3	Charge		Last	<input checked="" type="checkbox"/>	<input checked="" type="checkbox"/>	<input checked="" type="checkbox"/>	<input checked="" type="checkbox"/>	<input checked="" type="checkbox"/>	<input type="checkbox"/>	<input type="checkbox"/>	<input type="checkbox"/>
PIN	ASC0	MUX1	MUX2	MUX3	Charge		Last										
<input checked="" type="checkbox"/>	<input checked="" type="checkbox"/>	<input checked="" type="checkbox"/>	<input checked="" type="checkbox"/>	<input checked="" type="checkbox"/>	<input type="checkbox"/>	<input type="checkbox"/>	<input type="checkbox"/>										

### Parameter Description

`<numeric>`<sup>(str)</sup>

Operator in numeric form; GSM location area identification number

`<alpha>`<sup>(str)</sup>

Operator in long alphanumeric format; can contain up to 16 characters

## 8.12 AT^SPLR Read entry from the preferred operators list

The `AT^SPLR` write command returns used entries from the SIM list of preferred operators with `<indexa>` between `<index1>` and `<index2>`. If `<index2>` is not given, only entry at `<index1>` is returned. The test command returns the whole index range supported by the SIM.

See also GSM 07.07: AT+CPOL

### Syntax

<p>Test Command</p> <pre>AT^SPLR=?</pre> <p>Response(s)</p> <pre>^SPLR:(list of supported) &lt;indexa&gt;s OK ERROR +CME ERROR: &lt;err&gt;</pre>	<p>Write Command</p> <pre>AT^SPLR=&lt;index1&gt;[, &lt;index2&gt;]</pre> <p>Response(s)</p> <pre>^SPLR: &lt;index1&gt;&lt;oper&gt; ^SPLR: &lt;index2&gt;&lt;oper&gt; OK ERROR +CME ERROR: &lt;err&gt;</pre>																
<p>Reference(s)</p> <pre>--</pre>	<table border="1"> <thead> <tr> <th>PIN</th> <th>ASC0</th> <th>MUX1</th> <th>MUX2</th> <th>MUX3</th> <th>Charge</th> <th></th> <th>Last</th> </tr> </thead> <tbody> <tr> <td><input checked="" type="checkbox"/></td> <td><input checked="" type="checkbox"/></td> <td><input checked="" type="checkbox"/></td> <td><input checked="" type="checkbox"/></td> <td><input checked="" type="checkbox"/></td> <td><input type="checkbox"/></td> <td><input type="checkbox"/></td> <td><input type="checkbox"/></td> </tr> </tbody> </table>	PIN	ASC0	MUX1	MUX2	MUX3	Charge		Last	<input checked="" type="checkbox"/>	<input checked="" type="checkbox"/>	<input checked="" type="checkbox"/>	<input checked="" type="checkbox"/>	<input checked="" type="checkbox"/>	<input type="checkbox"/>	<input type="checkbox"/>	<input type="checkbox"/>
PIN	ASC0	MUX1	MUX2	MUX3	Charge		Last										
<input checked="" type="checkbox"/>	<input checked="" type="checkbox"/>	<input checked="" type="checkbox"/>	<input checked="" type="checkbox"/>	<input checked="" type="checkbox"/>	<input type="checkbox"/>	<input type="checkbox"/>	<input type="checkbox"/>										

### Parameter Description

`<index1>`<sup>(num)</sup>

Location number to start reading from

`<index2>`<sup>(num)</sup>

Location number where to stop reading

`<indexa>`<sup>(num)</sup>

Index range supported by the SIM card (between `<index1>` and `<index2>`)

`<oper>`<sup>(str)</sup>

Operator in numeric form; GSM location area identification number

## 8.13 AT^SPLW Write an entry to the preferred operators list

The `AT^SPLW` write command writes an entry to the SIM list of preferred operators at location number `<index>`. If `<index>` is given but `<oper>` is left out, the entry is deleted. An operator can be only once in the list. Test command returns the whole index range supported by the SIM. See also GSM 07.07: AT+CPOL

### Syntax

Test Command
AT^SPLW=?
Response(s)
^SPLW: (list of supported) <code>&lt;index&gt;</code> s
OK
ERROR
+CME ERROR:

Write Command
AT^SPLW= <code>&lt;index&gt;</code> [, <code>&lt;oper&gt;</code> ]
Response(s)
OK
ERROR
+CME ERROR: <code>&lt;err&gt;</code>

Reference(s)
--

PIN	ASC0	MUX1	MUX2	MUX3	Charge		Last
<input checked="" type="checkbox"/>	<input checked="" type="checkbox"/>	<input checked="" type="checkbox"/>	<input checked="" type="checkbox"/>	<input checked="" type="checkbox"/>	<input type="checkbox"/>	<input type="checkbox"/>	<input type="checkbox"/>

### Parameter Description

<code>&lt;index&gt;</code> <sup>(num)</sup>
location number

<code>&lt;oper&gt;</code> <sup>(str)</sup>
Operator in numeric format (GSM Location Area Identification number which consists of a 3-digit country code plus a 2- or 3-digit network code).

## 9. Supplementary Service Commands

The AT Commands described in this chapter are related to the Supplementary Services offered by the GSM network.

### 9.1 AT+CACM Accumulated call meter (ACM) reset or query

#### Syntax

Test Command AT+CACM=? Response(s) OK																	
Read Command AT+CACM? Response(s) +CACM: <acm> OK ERROR +CME ERROR: <err>																	
Write Command AT+CACM=[<passwd>] Response(s) OK ERROR +CME ERROR: <err>																	
Reference(s) GSM 07.07	<table border="1"> <tr> <td>PIN</td> <td>ASC0</td> <td>MUX1</td> <td>MUX2</td> <td>MUX3</td> <td>Charge</td> <td></td> <td>Last</td> </tr> <tr> <td>●</td> <td>●</td> <td>●</td> <td>●</td> <td>●</td> <td>○</td> <td>○</td> <td>○</td> </tr> </table>	PIN	ASC0	MUX1	MUX2	MUX3	Charge		Last	●	●	●	●	●	○	○	○
PIN	ASC0	MUX1	MUX2	MUX3	Charge		Last										
●	●	●	●	●	○	○	○										

#### Command Description

The read command returns the current ACM value.

The write command resets the Advice of Charge related to the accumulated call meter (ACM) value in SIM file EF(ACM). ACM contains the total number of home units for both the current and preceding calls.

#### Parameter Description

<acm> <sup>(str)</sup> Three bytes of the current ACM value in hexadecimal format (e.g. "00001E" indicates decimal value 30) 000000 - FFFFFFFF.
<passwd> <sup>(str)</sup> SIM PIN2

## 9.2 AT^SACM Advice of charge and query of ACM and ACMmax

### Syntax

<p>Test Command</p> <pre>AT^SACM=?</pre> <p>Response(s)</p> <pre>^SACM: (list of supported &lt;n&gt;s) OK</pre>																	
<p>Exec Command</p> <pre>AT^SACM</pre> <p>Response(s)</p> <pre>^SACM: &lt;n&gt;, &lt;acm&gt;, &lt;acmMax&gt; OK ERROR +CME ERROR: &lt;err&gt;</pre>																	
<p>Write Command</p> <pre>AT^SACM=&lt;n&gt;</pre> <p>Response(s)</p> <pre>OK ERROR +CME ERROR: &lt;err&gt;</pre>																	
<p>Reference(s)</p> <pre>--</pre>	<table border="1"> <thead> <tr> <th>PIN</th> <th>ASC0</th> <th>MUX1</th> <th>MUX2</th> <th>MUX3</th> <th>Charge</th> <th></th> <th>Last</th> </tr> </thead> <tbody> <tr> <td><input checked="" type="radio"/></td> <td><input checked="" type="radio"/></td> <td><input checked="" type="radio"/></td> <td><input checked="" type="radio"/></td> <td><input checked="" type="radio"/></td> <td><input type="radio"/></td> <td><input type="radio"/></td> <td><input type="radio"/></td> </tr> </tbody> </table>	PIN	ASC0	MUX1	MUX2	MUX3	Charge		Last	<input checked="" type="radio"/>	<input checked="" type="radio"/>	<input checked="" type="radio"/>	<input checked="" type="radio"/>	<input checked="" type="radio"/>	<input type="radio"/>	<input type="radio"/>	<input type="radio"/>
PIN	ASC0	MUX1	MUX2	MUX3	Charge		Last										
<input checked="" type="radio"/>	<input checked="" type="radio"/>	<input checked="" type="radio"/>	<input checked="" type="radio"/>	<input checked="" type="radio"/>	<input type="radio"/>	<input type="radio"/>	<input type="radio"/>										

### Unsolicited Result Code

+CCCM: <ccm>

When activated, an unsolicited result code is sent when the CCM value changes, but not more often than every 10 seconds.

### Command Description

The execute command can be used to query the current mode of the Advice of Charge supplementary service, the SIM values of the accumulated call meter (ACM) and accumulated call meter maximum (ACMmax).

The write command enables or disables the presentation of unsolicited result codes to report the call charges.

### Parameter Description

<b>&lt;n&gt;</b> <sup>(num)(&amp;W)(&amp;V)</sup>	
[0] <sup>(&amp;F)</sup>	suppress unsolicited result code
1	display unsolicited result code
<b>&lt;acm&gt;</b> <sup>(str)(&amp;V)</sup>	
Three bytes of the current ACM value in hexadecimal format (e.g. "00001E" indicates decimal value 30) 000000-FFFFFF	
<b>&lt;acmMax&gt;</b> <sup>(str)(&amp;V)</sup>	
Three bytes of the max. ACM value in hexadecimal format (e.g. "00001E" indicates decimal value 30) 000000 disable ACMmax feature 000001-FFFFFF	

---

<CCM><sup>(str)</sup>

Three bytes of the current CCM value in hexadecimal format (e.g. "00001E" indicates decimal value 30); bytes are coded in the same way as ACMmax value in the SIM 000000-FFFFFF

### Notes

- When you power down or reset the ME with [AT+CFUN=1,1](#) the URC presentation mode will be reset to its default. To benefit from the URC it is recommended to have the setting included in the user profile saved with [AT+W](#), or to select <n>=1 every time you reboot the ME.
- See also GSM07.07: [AT+CACM](#), [AT+CAMM](#), [AT+CAOC](#).

## 9.3 AT+CAMM Accumulated call meter maximum (ACMmax) set or query

### Syntax

<p>Test Command</p> <p>AT+CAMM=?</p> <p>Response(s)</p> <p>OK</p>																	
<p>Read Command</p> <p>AT+CAMM?</p> <p>Response(s)</p> <p>+CAMM: &lt;acmmax&gt;</p> <p>OK</p> <p>ERROR</p> <p>+CME ERROR: &lt;err&gt;</p>																	
<p>Write Command</p> <p>AT+CAMM=[&lt;acmmax&gt;[, &lt;passwd&gt;]]</p> <p>Response(s)</p> <p>OK</p> <p>ERROR</p> <p>+CME ERROR: &lt;err&gt;</p>																	
<p>Reference(s)</p> <p>GSM 07.07</p>	<table border="1"> <thead> <tr> <th>PIN</th> <th>ASC0</th> <th>MUX1</th> <th>MUX2</th> <th>MUX3</th> <th>Charge</th> <th>⚡</th> <th>Last</th> </tr> </thead> <tbody> <tr> <td>●</td> <td>●</td> <td>●</td> <td>●</td> <td>●</td> <td>○</td> <td>○</td> <td>○</td> </tr> </tbody> </table>	PIN	ASC0	MUX1	MUX2	MUX3	Charge	⚡	Last	●	●	●	●	●	○	○	○
PIN	ASC0	MUX1	MUX2	MUX3	Charge	⚡	Last										
●	●	●	●	●	○	○	○										

### Command Description

The read command returns the current ACMmax value.

The write command sets the Advice of Charge related to the accumulated call meter maximum value in SIM file EF (ACMmax). ACMmax contains the maximum number of home units allowed to be consumed by the subscriber.

### Parameter Description

<acmmax><sup>(str)</sup>

Three bytes of the max. ACM value in hexadecimal format (e.g. "00001E" indicates decimal value 30) 000000 disable ACMmax feature 000001-FFFFFF.

<passwd><sup>(str)</sup>

SIM PIN2

## 9.4 AT+CAOC Advice of Charge information

### Syntax

<p>Test Command</p> <pre>AT+CAOC=?</pre> <p>Response(s)</p> <pre>+CAOC: (list of supported&lt;mode&gt;s) OK</pre>																	
<p>Read Command</p> <pre>AT+CAOC?</pre> <p>Response(s)</p> <pre>+CAOC: &lt;mode&gt; OK</pre>																	
<p>Exec Command</p> <pre>AT+CAOC</pre> <p>Response(s)</p> <pre>ERROR +CME ERROR: &lt;err&gt; If &lt;mode&gt;=0, TA returns the current call meter value: +CAOC: &lt;ccm&gt; OK</pre>																	
<p>Write Command</p> <pre>AT+CAOC=[&lt;mode&gt;]</pre> <p>Response(s)</p> <pre>ERROR +CME ERROR: &lt;err&gt; If &lt;mode&gt;=0, TA returns the current call meter value. OK</pre>																	
<p>Reference(s)</p> <p>GSM 07.07</p>	<table border="1"> <thead> <tr> <th>PIN</th> <th>ASC0</th> <th>MUX1</th> <th>MUX2</th> <th>MUX3</th> <th>Charge</th> <th></th> <th>Last</th> </tr> </thead> <tbody> <tr> <td><input checked="" type="radio"/></td> <td><input checked="" type="radio"/></td> <td><input checked="" type="radio"/></td> <td><input checked="" type="radio"/></td> <td><input checked="" type="radio"/></td> <td><input type="radio"/></td> <td><input type="radio"/></td> <td><input type="radio"/></td> </tr> </tbody> </table>	PIN	ASC0	MUX1	MUX2	MUX3	Charge		Last	<input checked="" type="radio"/>	<input checked="" type="radio"/>	<input checked="" type="radio"/>	<input checked="" type="radio"/>	<input checked="" type="radio"/>	<input type="radio"/>	<input type="radio"/>	<input type="radio"/>
PIN	ASC0	MUX1	MUX2	MUX3	Charge		Last										
<input checked="" type="radio"/>	<input checked="" type="radio"/>	<input checked="" type="radio"/>	<input checked="" type="radio"/>	<input checked="" type="radio"/>	<input type="radio"/>	<input type="radio"/>	<input type="radio"/>										

### Command Description

Execute command returns the current call meter value.  
The write command sets the Advice of Charge supplementary service function mode.

### Parameter Description

<mode> <sup>(num)&amp;(V)</sup>	
0	query CCM value
<ccm> <sup>(str)</sup>	
Three bytes of the current CCM value in hexadecimal format (e.g. "00001E" indicates decimal value 30); bytes are similarly coded as ACMmax value in the SIM 000000-FFFFFF.	



## 9.5 AT+CCUG Closed User Group

### Syntax

#### Test Command

AT+CCUG=?

#### Response(s)

+CCUG: list of supported <n>, range of supported <index>, range of supported <info>  
OK  
ERROR  
+CME ERROR

#### Read Command

AT+CCUG?

#### Response(s)

+CCUG: <n>, <index>, <info>  
OK  
ERROR  
+CME ERROR

#### Write Command

AT+CCUG=[[<n>][, <index>][, <info>]]

#### Response(s)

OK  
ERROR  
+CME ERROR

#### Reference(s)

GSM 07.07, GSM 02.85, GSM 03.85,  
GSM 04.85

PIN	ASC0	MUX1	MUX2	MUX3	Charge		Last
<input checked="" type="radio"/>	<input checked="" type="radio"/>	<input checked="" type="radio"/>	<input checked="" type="radio"/>	<input checked="" type="radio"/>	<input type="radio"/>	<input type="radio"/>	<input type="radio"/>

### Command Description

The Test command returns the supported parameters.

The Read command returns if the Explicit CUG invocation is activated (in parameter <n>), which CUG <index> is chosen, and if Preferential Group or Outgoing Access is suppressed (in parameter <info>).

The write command serves to activate or deactivate the explicit CUG invocation, to set the desired index, and to specify if Preferential Group or Outgoing Access shall be suppressed.

### Parameter Description

<n><sup>(num)</sup>

explicit CUG invocation options

0 <sup>(D)</sup>	Deactivate explicit CUG invocation
1	Activate explicit CUG invocation

<index><sup>(num)</sup>

0-9	explicit selection of CUG index
10 <sup>(D)</sup>	No index (preferred CUG taken from subscriber data)

<info><sup>(num)</sup>

state of the call

0 <sup>(D)</sup>	no information
1	suppress outgoing access
2	suppress preferential CUG
3	Suppress preferential CUG and Outgoing Access.

### Notes

- The active settings for omitted parameters are retained without changes.
- Explicit CUG invocation means that at each call setup, CUG information is added to the called number.
- Upon delivery, settings are predefined with  
    <n>=0,  
    <index>=10,  
    <info>=0.  
    These delivery defaults cannot be recalled automatically.
- When starting a call with [ATD](#), Parameter 'G' or 'g' of command [ATD](#) will have no effect if the option selected for this single call is identical to the option already selected with [AT+CCUG](#).
- Current settings are saved in the ME automatically.
- [ATZ](#) or [AT&F](#) do not influence the current settings.
- some combinations of parameters may lead to rejection of CUG calls by the network. For more information, please consult GSM 04.85

## 9.6 AT+CCFC Call forwarding number and conditions control

AT+CCFC controls the call forwarding supplementary service. Registration, erasure, activation, deactivation and status query are supported.

### Syntax

<p>Test Command</p> <p>AT+CCFC=?</p> <p>Response(s)</p> <p>+CCFC: (list/range of supported &lt;reason&gt;s)</p> <p>OK</p>																	
<p>Write Command</p> <p>AT+CCFC=&lt;reason&gt;, &lt;mode&gt;[, &lt;number&gt;[, &lt;type&gt;[, &lt;class&gt;[, &lt;time&gt;]]]]</p> <p>Response(s)</p> <p>If &lt;mode&gt; is not equal 2 and command successful:</p> <p>OK</p> <p>If &lt;mode&gt;= 2, &lt;reason&gt; is not equal 2 and command successful:</p> <p>+CCFC: &lt;status&gt;, &lt;class&gt;[, &lt;number&gt;, &lt;type&gt;]</p> <p>OK</p> <p>If &lt;mode&gt;= 2, &lt;reason&gt;= 2 and command successful:</p> <p>+CCFC: &lt;status&gt;, &lt;class&gt;[, &lt;number&gt;, &lt;type&gt;, &lt;time&gt;]</p> <p>OK</p> <p>If error is related to ME functionality</p> <p>+CME ERROR</p>																	
<p>Reference(s)</p> <p>GSM 07.07, GSM 02.04, GSM 02.82, GSM 03.82, GSM 04.82</p>	<table border="1"> <tr> <td>PIN</td> <td>ASC0</td> <td>MUX1</td> <td>MUX2</td> <td>MUX3</td> <td>Charge</td> <td></td> <td>Last</td> </tr> <tr> <td>●</td> <td>●</td> <td>●</td> <td>●</td> <td>●</td> <td>○</td> <td>○</td> <td>○</td> </tr> </table>	PIN	ASC0	MUX1	MUX2	MUX3	Charge		Last	●	●	●	●	●	○	○	○
PIN	ASC0	MUX1	MUX2	MUX3	Charge		Last										
●	●	●	●	●	○	○	○										

### Parameter Description

<reason> <sup>(num)</sup>	
Reason for call forwarding	
0	unconditional
1	mobile busy
2	no reply
3	not reachable
4	all call forwarding (includes reasons 0, 1, 2 and 3)
5	all conditional call forwarding (includes reasons 1, 2 and 3)
<mode> <sup>(num)</sup>	
Network operation to be performed for Supplementary service "call forwarding"	
0	disable call forwarding (disable service)
1	enable call forwarding (enable service)
2	query status of call forwarding (query service status)
3	register <number> and activate call forwarding (register service)
4	erase <number> and deactivate call forwarding (erase service)

<number><sup>(str)</sup>

String type phone number of forwarding address in format specified by <type>. If you select <mode>= 3, the phone <number> will be registered in the network. This allows you to disable / enable CF to the same destination without the need to enter the phone number once again. Depending on the services offered by the provider the registration may be mandatory before CF can be used. The number remains registered in the network until you register another number or erase it using <mode> = 4.

<type><sup>(num)</sup>

Type of address octect

145	dialing string <number> includes international access code character '+'
129	otherwise

<class><sup>(num)</sup>

Integer or sum of integers each representing a class of information, i.e. a bearer service, telecommunication service or bearer service group as defined in "GSM 02.04"

1	voice
2	data <class> 2 (data) comprises all those <class> values between 16 and 128, that are supported both by the network and the MS. This means, a setting made for <class> 2 applies to all remaining data classes (if supported). In addition, you can assign a different setting to a specific class. For example, you can activate Call Forwarding for all data classes, but deactivate it for a specific data class.
4	fax
8	SMS
16	data circuit sync
32	data circuit async
64	dedicated packet access
128	dedicated PAD access
1...[7]...255	combination of some of the above classes. For example, the default setting 7 represents the sum of the integers 1, 2 and 4 (CF for voice, data and fax). The value 255 covers all classes. If the <class> parameter is omitted, the default value 7 is used.

<time><sup>(num)</sup>

5...[20]...30	Time to wait before call is forwarded, rounded to a multiple of 5 sec. (only for <reason>=no reply)
---------------	---

<status><sup>(num)</sup>

0	Call Forwarding not active
1	Call Forwarding active

### Notes

- You can register, disable, enable and erase <reason> 4 and 5 as described above. However, querying the status of <reason> 4 and 5 with AT+CCFC will result in an error ("CME error: Operation not supported"). As an alternative, you may use the ATD command followed by \*# codes to check the status of these two reasons. See [Star-Hash \(\\*#\) Network Commands](#) for a complete listof \*# GSM codes. See also examples below.
- Most networks will not permit registration of new parameters for conditional call forwarding (reasons 1,2,3,5) while unconditional call forwarding is enabled.
- The AT+CCFC command offers a broad range of call forwarding options according to the GSM specifications.

However, when you attempt to set a call forwarding option which is not provisioned or not yet subscribed to, the setting will not take effect regardless of the response returned. The responses in these cases vary with the network (for example "OK", "Operation not allowed", "Operation not supported" etc.). To make sure check the call forwarding status with `<mode>=2`.

- Some networks may choose to have certain call forwarding conditions permanently enabled (e.g. forwarding to a mailbox if the mobile is not reachable). In this case, erasure or deactivation of call forwarding for these conditions will not be successful, even if the CCFC request is answered with response "OK".
- The command has been implemented with the full set of `<class>` parameters according to GSM 07.07. For actual applicability of SS "call forwarding" to a specific service or service group (a specific `<class>` value) please consult table A.1 of GSM 02.04.
- There is currently no release of GSM standard "GSM 02.04", in which the "Call Forwarding" Supplementary Service is defined as applicable to SMS services.

### Example

Please note that when you configure or query call forwarding without specifying any classes, the settings will refer to classes 1, 2 and 4 only (=default). The handling of classes is equivalent to [AT+CLCK](#).

- To register the destination number for unconditional call forwarding (CFU):

```
at+ccfc=0,3,"+493012345678",145
OK
```

The destination number will be registered for voice, data and fax services (default `<class>` 7). In most networks, the registration will also cause call forwarding to be activated for these `<class>` values.

- To query the status of CFU without specifying `<class>`:

```
at+ccfc=0,2
+CCFC: 1,1,"+493012345678",145
+CCFC: 1,2,"+493012345678",145
+CCFC: 1,4,"+493012345678",145
OK
```

- To deactivate CFU without specifying `<class>`:

```
at+ccfc=0,0
OK
```

To check whether CFU was successfully deactivated (note that the destination number remains registered in the network when you disable CFU):

```
at+ccfc=0,2
+CCFC: 0,1,"+493012345678",145
+CCFC: 0,2,"+493012345678",145
+CCFC: 0,4,"+493012345678",145
OK
```

- To erase the registered CFU destination number:

```
at+ccfc=0,4
OK
```

Now, when you check the status, no destination number will be indicated:

```
at+ccfc=0,2
+CCFC: 0,1
+CCFC: 0,2
+CCFC: 0,4
OK
```

- To query the status of CFU for all classes:

```
at+ccfc=0,2,,,255
+CCFC: 0,1
+CCFC: 0,2
+CCFC: 0,4
+CCFC: 0,8
+CCFC: 0,16
+CCFC: 0,32
+CCFC: 0,64
+CCFC: 0,128
OK
```



- [<reason>](#) 4 or 5 cannot be used to query the status of all call forwarding reasons (see also notes above):

```
at+ccfc=4,2
+CME error: operation not supported
at+ccfc=5,2
+CME error: operation not supported
```

## 9.7 AT+CCWA Call Waiting

The **AT+CCWA** write command controls the "Call Waiting" supplementary service according to GSM 02.83. Activation, deactivation and status query are supported. The read command returns the current value of **<n>**.

### Syntax

<p>Test Command</p> <pre>AT+CCWA=?</pre> <p>Response(s)</p> <pre>+CCWA: (list of supported &lt;n&gt;s) OK</pre>																	
<p>Read Command</p> <pre>AT+CCWA?</pre> <p>Response(s)</p> <pre>+CCWA: &lt;n&gt; OK</pre>																	
<p>Write Command</p> <pre>AT+CCWA=[[&lt;n&gt;][, &lt;mode&gt;][, &lt;class&gt;]]</pre> <p>Response(s)</p> <p>If <b>&lt;mode&gt;</b> is not equal 2 and command successful:</p> <pre>OK</pre> <p>If <b>&lt;mode&gt;</b>= 2 and command successful:</p> <pre>+CCWA: &lt;status&gt;, &lt;class&gt; [+CCWA: &lt;status&gt;, &lt;class&gt;] [+CCWA: ...] OK</pre> <p>If error is related to ME functionality</p> <pre>+CME ERROR</pre>																	
<p>Reference(s)</p> <pre>GSM 07.07, GSM 02.04, GSM 02.83, GSM 03.83, GSM 04.83</pre>	<table border="1"> <thead> <tr> <th>PIN</th> <th>ASC0</th> <th>MUX1</th> <th>MUX2</th> <th>MUX3</th> <th>Charge</th> <th></th> <th>Last</th> </tr> </thead> <tbody> <tr> <td>●</td> <td>●</td> <td>●</td> <td>●</td> <td>●</td> <td>○</td> <td>○</td> <td>○</td> </tr> </tbody> </table>	PIN	ASC0	MUX1	MUX2	MUX3	Charge		Last	●	●	●	●	●	○	○	○
PIN	ASC0	MUX1	MUX2	MUX3	Charge		Last										
●	●	●	●	●	○	○	○										

### Unsolicited Result Codes

#### URC 1

Indication of a call that is currently waiting and can be accepted.

```
+CCWA: <calling number>, <type of number>, <class>, , <CLI validity>
```

If **<n>**=1 and the call waiting supplementary service is enabled in the network, URC "+CCWA" indicates a waiting call to the TE. It appears while the waiting call is still ringing.

#### URC 2

Indication of a call that has been waiting.

```
^SCWA
```

If **<n>**=1 and the call waiting supplementary service is enabled in the network, this URC indicates that a waiting call rang when the ME was in online mode during a CSD call, but the calling party hung up before the ME went back to command mode.

### Parameter Description

`<n>`<sup>(num)</sup>

Switch URCs "+CCWA" and "^SCWA" for call waiting on/off

- |   |   |
|---|---|
| 0 | Disable display of URCs "+CCWA" and "^SCWA" |
| 1 | Enable display of URCs "+CCWA" and "^SCWA"  |

`<mode>`<sup>(num)</sup>

Network operation to be performed for Supplementary service call waiting

- |   |   |
|---|---|
| 0 | Disable call waiting (disable service)              |
| 1 | Enable call waiting (enable service)                |
| 2 | Query status of call waiting (query service status) |

`<class>`<sup>(num)</sup>

Integer or sum of integers each representing a class of information, i.e. a bearer service, telecommunication service or bearer service group as defined in "GSM 02.04".

In the write command, parameter `<class>` specifies the class of the active call during which an incoming call of any class is to be regarded as a waiting call.

In URC "+CCWA: `<calling number>`, `<type of number>`, `<class>`, , `<CLI validity>`", parameter `<class>` specifies the class of the waiting call.

- |               |  |
|---------------|--|
| 1             | Voice  |
| 2             | Data<br><class> 2 (data) comprises all those <class> values between 16 and 128, that are supported both by the network and the MS. This means, a setting made for <class> 2 applies to all remaining data classes (if supported). In addition, you can assign a different setting to a specific class. For example, you can activate call waiting for all data classes, but deactivate it for a specific data class. |
| 4             | Fax  |
| [7]           | Voice, data and fax (1+2+4)  |
| 8             | SMS  |
| 16            | Data circuit sync  |
| 32            | Data circuit async   |
| 64            | Dedicated packet access  |
| 128           | Dedicated PAD access   |
| 1...[7]...255 | Combination of some of the above classes. For example, the default setting 7 represents the sum of the integers 1, 2 and 4 (CF for voice, data and fax). The value 255 covers all classes. If parameter "class" is omitted, the default value 7 is used.   |

`<status>`<sup>(num)</sup>

- |   |                                    |
|---|------------------------------------|
| 0 | Call waiting service is not active |
| 1 | Call waiting service is active     |

`<calling number>`<sup>(str)</sup>

Phone number of waiting caller in the format specified by parameter `<type of number>`.

`<type of number>`<sup>(num)</sup>

Type of address octet in integer format (refer to GSM 04.08, subclause 10.5.4.7)

- |     |  |
|-----|--|
| 145 | <code>&lt;calling number&gt;</code> includes international access code character '+' |
|-----|--|



128	number restricted
129	Otherwise

#### <CLI validity><sup>(num)</sup>

0	CLI valid
1	CLI has been withheld
2	CLI is not available

### Notes

- If the active call is a CS D call, and a waiting call is received, then the ME produces a BREAK while still in online mode, and displays
  - the +CCWA URC (as above) when the ME goes back to command mode while the waiting call is still active and can be accepted;
  - or the ^SCWA URC (as above) when the ME goes back to command mode after the waiting call has ended.
- With the AT+CHLD command, it is possible to establish a multiparty call or to set the active voice call on hold and then accept a waiting voice call (not possible with fax and data call). See also [AT+CHLD](#)
- Users should be aware that if call waiting is activated (<mode>=1), the presentation of URCs needs to be enabled, too (<n>=1). Otherwise, on the one hand, a waiting caller would be kept waiting due to lack of BUSY signals, while, on the other hand, the waiting call would not be indicated to the called party.
- The AT+CCWA command offers a broad range of options according to the GSM specifications. However, when you attempt to enable call waiting for a <class> for which the service is not provisioned or not supported, the setting will not take effect regardless of the response returned. The responses in these cases vary with the network (for example "OK", "Operation not allowed", "Operation not supported" etc.). To make sure check the current call waiting settings with <mode>=2.
- The AT+CCWA command has been implemented with the full set of <class> parameters according to GSM 07.07. For actual applicability of SS call waiting to a specific service or service group (a specific <class> value) please consult table A.1 of GSM 02.04
- Despite the specifications stated in GSM 02.04 call waiting is not handled uniformly among all networks: GSM 02.04, Annex A, provides the following specification:  
 "The applicability of call waiting refers to the telecommunication service of the active call and not of the waiting call. The incoming, waiting, call may be of any kind." Nevertheless, networks do differ on the actual implementation of the service. For example, the activation of call waiting for <class> 4, "fax", causes some networks to send a call waiting indication if a call "of any kind" comes in during an active fax call, but others may (with the same settings active) indicate a waiting fax call during any kind of active call. Thus, the only reliable way to receive or prevent a call waiting indication under any circumstances and in any network, is to activate or deactivate call waiting for all tele- and bearer services (<class> 255).

## Examples

### EXAMPLE 1

Parameter **<n>**

```
at+ccwa=1          To enable the presentation of the URC
OK
```

### EXAMPLE 2

Parameter **<mode>**

```
at+ccwa=,1        To activate the supplementary service in the network for voice, data,
                  and fax calls (default classes).
                  Note that parameter <n> is left out. In this case, the current value of <n>
                  will be retained.

OK
at+ccwa=,2        To query the network status of call waiting for default classes
at+ccwa=1,1       Call Waiting is activated during voice calls.
at+ccwa=1,2       Call Waiting is activated during data calls.
at+ccwa=1,4       Call Waiting is activated during fax calls.
OK
```

### EXAMPLE 3

Parameter **<class>**

```
AT+CCWA=,0,1     To deactivate call waiting for voice calls.
OK
```

## 9.8 AT+CHLD Call Hold and Multiparty

### Syntax

<p>Test Command</p> <pre>AT+CHLD=?</pre> <p>Response(s)</p> <pre>+CHLD: (list of supported &lt;n&gt;s) OK</pre>																	
<p>Write Command</p> <pre>AT+CHLD=&lt;n&gt;</pre> <p>Response(s)</p> <pre>OK ERROR +CME ERROR: &lt;err&gt;</pre>																	
<p>Reference(s)</p> <p>GSM 07.07</p>	<table border="1"> <thead> <tr> <th>PIN</th> <th>ASC0</th> <th>MUX1</th> <th>MUX2</th> <th>MUX3</th> <th>Charge</th> <th></th> <th>Last</th> </tr> </thead> <tbody> <tr> <td>●</td> <td>●</td> <td>●</td> <td>●</td> <td>●</td> <td>○</td> <td>○</td> <td>○</td> </tr> </tbody> </table>	PIN	ASC0	MUX1	MUX2	MUX3	Charge		Last	●	●	●	●	●	○	○	○
PIN	ASC0	MUX1	MUX2	MUX3	Charge		Last										
●	●	●	●	●	○	○	○										

### Command Description

TA controls the Supplementary Services Call Hold and Multiparty. Calls can be put on hold, recovered, released, and added to a conversation.

Like for all Supplementary Services, the availability and detailed functionality of Call Hold and Multiparty services depends on the configuration of the GSM network. The TC35i can only request the service, but the network decides whether and how the request will be answered.

### Parameter Description

<n> <sup>(num)</sup>	
0	<p>Release all held calls or set User Determined User Busy (UDUB) for a waiting call:</p> <ul style="list-style-type: none"> <li>If a call is waiting, release the waiting call. The calling party will receive a "BUSY" indication ( Supplementary Service User Determined User Busy "UDUB")</li> <li>Otherwise, terminate all held calls (if any).</li> </ul>
1	<p>Terminate all active calls (if any) and accept "the other call" as the active call:</p> <ul style="list-style-type: none"> <li>If a call is waiting, the waiting call will be accepted.</li> <li>Otherwise, if a held call is present, the held call becomes active.</li> </ul>
1X	<p>Terminate a specific call X (X= 1-7). The call may be active, held or waiting. The remote party of the terminated call will receive a "NO CARRIER" indication. Parameter X is the call number&lt;idx&gt; of the targeted call in the list of current calls available with AT command <a href="#">AT+CLCC</a>.</p>
2	<p>Place all active calls on hold (if any) and accept "the other call" as the active call:</p> <ul style="list-style-type: none"> <li>If a call is waiting, the waiting call will be accepted.</li> <li>Otherwise, if a held call is present, the held call becomes active.</li> </ul>
2X	<p>Place all active calls except call X (X= 1-7) on hold. Parameter X is the call number &lt;idx&gt; of the targeted call in the list of current calls available with AT command <a href="#">AT+CLCC</a>.</p>
3	<p>Add a held call to the active calls in order to set up a conference (multiparty) call.</p>

## Notes

- The **AT+CHLD** command offers a broad range of options according to the GSM specifications. However, if you attempt to invoke an option which is not provisioned by the network, or not subscribed to, invocation of this option will fail. The responses in these cases may vary with the network (for example "Operation not allowed", "Operation not supported" etc.).
- The handling of the supplementary service Call hold and Multiparty varies with the types of calls. This is because only voice calls can be put on hold, while data or fax calls cannot. The following procedures apply: With **AT+CHLD=2** the user can simultaneously place a voice call on hold and accept another waiting voice, data or fax call. If the waiting call is a data or fax call, it is also possible to put the voice call on hold. The user needs to wait for the RING signal and manually answer the data / fax call with ATA. To switch back from the active data or fax call to the held voice call the active call must be terminated with **AT+CHLD=1**. If all active and held calls are voice calls it is possible to switch back and forth with **AT+CHLD=2**.
- In conflict situations, e.g. when a waiting call comes while there are already held calls, the above procedures apply to the waiting call only. For example, **<n>=0** rejects the waiting call, but does not affect the held calls.
- See also the **AT+CCWA** command for details on how to display waiting calls.

## Example

```
^SYSSTART
at+cpin="9999"
OK

+CREG: 2

+CREG: 1,"0145","0016"
at+ccwa=1,1,1

OK
atd"1234567";
OK
+CCWA: "+491791292364",145,32,,0
at+chld=2
OK
RING

RING

RING
ATA
OK
CONNECT 9600/RLP
hello
+++
OK
at+clcc
+CLCC: 1,0,1,0,0,"03038639268",129
+CLCC: 2,1,0,1,0,"+491791292364",145
OK
at+chld=1

OK
at+clcc
+CLCC: 1,0,0,0,0,"03038639268",129
OK
```

The mobile is now registered.  
You activate the indication of waiting calls during voice calls.

You make a voice call.

You receive a URC indicating a waiting data call.  
You put the voice call on hold.

You now receive the RING of the data call.

You accept the data call.

The data connection is set up.

With "+++" you go in command mode.

You interrogate the status of all established calls.

The active data call is terminated and the held voice call becomes active.

## 9.9 AT+CLIP Calling line identification presentation

This command refers to the GSM supplementary service CLIP (Calling Line Identification Presentation) that enables a called subscriber to get the calling line identity (CLI) of the calling party when receiving a mobile terminated call.

### Syntax

<p>Test Command</p> <pre>AT+CLIP=?</pre> <p>Response(s)</p> <pre>+CLIP: (list of supported&lt;n&gt;s) OK</pre>																	
<p>Read Command</p> <pre>AT+CLIP?</pre> <p>Response(s)</p> <pre>+CLIP: &lt;n&gt;, &lt;m&gt; OK ERROR +CME ERROR: &lt;err&gt;</pre>																	
<p>Write Command</p> <pre>AT+CLIP=&lt;n&gt;</pre> <p>Response(s)</p> <pre>OK ERROR +CME ERROR: &lt;err&gt;</pre>																	
<p>Reference(s)</p> <pre>GSM 07.07, GSM 02.81</pre>	<table border="1"> <tr> <td>PIN</td> <td>ASC0</td> <td>MUX1</td> <td>MUX2</td> <td>MUX3</td> <td>Charge</td> <td></td> <td>Last</td> </tr> <tr> <td><input type="radio"/></td> <td><input type="radio"/></td> <td><input type="radio"/></td> <td><input type="radio"/></td> <td><input type="radio"/></td> <td><input type="radio"/></td> <td><input type="radio"/></td> <td><input type="radio"/></td> </tr> </table>	PIN	ASC0	MUX1	MUX2	MUX3	Charge		Last	<input type="radio"/>	<input type="radio"/>	<input type="radio"/>	<input type="radio"/>	<input type="radio"/>	<input type="radio"/>	<input type="radio"/>	<input type="radio"/>
PIN	ASC0	MUX1	MUX2	MUX3	Charge		Last										
<input type="radio"/>	<input type="radio"/>	<input type="radio"/>	<input type="radio"/>	<input type="radio"/>	<input type="radio"/>	<input type="radio"/>	<input type="radio"/>										

### Unsolicited Result Codes

#### URC 1

Voice call response format:

```
+CLIP: <number>, <type>, , [, <alpha>][, <CLI validity>]
```

#### URC 2

Data/FAX call response format:

```
+CLIP: <number>, <type>
```

When CLIP is enabled at the TE ( and is permitted by the calling subscriber), an unsolicited result code is returned after every RING (or +CRING: <type>) at a mobile terminating call.

### Command Description

Test command returns values supported by the TA as a compound value.

Read command gives the status of <n>, and also triggers an interrogation of the provision status of the CLIP service according GSM 02.81 (given in <m>).

If no SIM card is available or SIM-Pin isn't entered, the command response is "ERROR".

Write command enables or disables the presentation of the CLI at the TE. It has no effect on the execution of the supplementary service CLIP in the network.

### Parameter Description

**<n>**<sup>(num)(&W)(&V)</sup>

[0] <sup>(&amp;F)</sup>	suppress unsolicited result codes
1	display unsolicited result codes

**<m>**<sup>(num)(&V)</sup>

0	CLIP not provisioned
1	CLIP provisioned
2	unknown

**<number>**<sup>(str)</sup>

string type phone number of calling address in format specified by [<type>](#)

**<type>**<sup>(num)</sup>

type of address octet in integer format; 145 when dialling string includes in-ternational access code character "+", otherwise 129.

**<alpha>**<sup>(str)</sup>

string type alphanumeric representation of [<number>](#) corresponding to the entry found in phonebook; used character set should be the one selected with command Select TE Character Set [AT+CSCS](#)

**<CLI validity>**<sup>(num)</sup>

0	CLI valid
1	CLI has been withheld by the originator.
2	CLI is not available due to in terworking problems or limitati ons of originating network. <a href="#">&lt;number&gt;</a> shall be an empty string ("") and <a href="#">&lt;type&gt;</a> value will not be significant.

When CLI is not available ( [<CLI validity>](#)=2), [<number>](#) shall be an empty string ("") and [<type>](#) value will not be significant. Nevertheless, TA shall return the recommended value 128 for [<type>](#) (T ON/NPI unknown in accordance with GSM 04.08 subclause 10.5.4.7).

When CLI has been withheld by the originator, ([<CLI validity>](#)=1) and the CLIP is provisioned with the "override category" option (refer GSM 02.81 and GSM 03.81), [<number>](#) and [<type>](#) is provided. Otherwise, TA shall return the same setting for [<number>](#) and [<type>](#) as if the CLI was not available.

## 9.10 AT+CLIR Calling line identification restriction

This command refers to the GSM supplementary service CLIR (Calling Line Identification Restriction).

### Syntax

<p>Test Command</p> <p>AT+CLIR=?</p> <p>Response(s)</p> <p>+CLIR: (list of supported &lt;n&gt;s)</p> <p>OK</p>																	
<p>Read Command</p> <p>AT+CLIR?</p> <p>Response(s)</p> <p>+CLIR&lt;n&gt;, &lt;m&gt;</p> <p>OK</p> <p>ERROR</p> <p>+CME ERROR: &lt;err&gt;</p>																	
<p>Write Command</p> <p>AT+CLIR=[&lt;n&gt;]</p> <p>Response(s)</p> <p>OK</p> <p>ERROR</p> <p>+CME ERROR: &lt;err&gt;</p>																	
<p>Reference(s)</p> <p>GSM 07.07</p>	<table border="1"> <tr> <td>PIN</td> <td>ASC0</td> <td>MUX1</td> <td>MUX2</td> <td>MUX3</td> <td>Charge</td> <td></td> <td>Last</td> </tr> <tr> <td><input checked="" type="radio"/></td> <td><input checked="" type="radio"/></td> <td><input checked="" type="radio"/></td> <td><input checked="" type="radio"/></td> <td><input checked="" type="radio"/></td> <td><input type="radio"/></td> <td><input type="radio"/></td> <td><input type="radio"/></td> </tr> </table>	PIN	ASC0	MUX1	MUX2	MUX3	Charge		Last	<input checked="" type="radio"/>	<input checked="" type="radio"/>	<input checked="" type="radio"/>	<input checked="" type="radio"/>	<input checked="" type="radio"/>	<input type="radio"/>	<input type="radio"/>	<input type="radio"/>
PIN	ASC0	MUX1	MUX2	MUX3	Charge		Last										
<input checked="" type="radio"/>	<input checked="" type="radio"/>	<input checked="" type="radio"/>	<input checked="" type="radio"/>	<input checked="" type="radio"/>	<input type="radio"/>	<input type="radio"/>	<input type="radio"/>										

### Parameter Description

<b>&lt;n&gt;<sup>(num)</sup></b>	
Parameter shows the settings for outgoing calls:	
[0] <sup>(P)</sup>	Presentation indicator is used according to the subscription of the CLIR service
1	CLIR invocation
2	CLIR suppression
<b>&lt;m&gt;<sup>(num)</sup></b>	
Parameter shows the subscriber CLIR service status in the network:	
0	CLIR not provisioned
1	CLIR provisioned in permanent mode
2	Unknown (e.g. no network, etc.)
3	CLIR temporary mode presentation restricted
4	CLIR temporary mode presentation allowed

### Note

- The settings made with **AT+CLIR=1** or **AT+CLIR=2** are used for all outgoing calls until the ME is switched off or **AT+CLIR=0** is used.

## 9.11 AT+CPUC Price per unit and currency table

### Syntax

<p>Test Command</p> <pre>AT+CPUC=?</pre> <p>Response(s)</p> <pre>OK</pre>																	
<p>Read Command</p> <pre>AT+CPUC?</pre> <p>Response(s)</p> <pre>+CPUC: &lt;currency&gt;, &lt;ppu&gt;</pre> <pre>OK</pre> <pre>ERROR</pre> <pre>+CME ERROR: &lt;err&gt;</pre>																	
<p>Write Command</p> <pre>AT+CPUC=&lt;currency&gt;, &lt;ppu&gt;[, &lt;passwd&gt;]</pre> <p>Response(s)</p> <pre>OK</pre> <pre>ERROR</pre> <pre>+CME ERROR: &lt;err&gt;</pre>																	
<p>Reference(s)</p> <pre>GSM 07.07</pre>	<table border="1"> <thead> <tr> <th>PIN</th> <th>ASC0</th> <th>MUX1</th> <th>MUX2</th> <th>MUX3</th> <th>Charge</th> <th></th> <th>Last</th> </tr> </thead> <tbody> <tr> <td>●</td> <td>●</td> <td>●</td> <td>●</td> <td>●</td> <td>○</td> <td>○</td> <td>○</td> </tr> </tbody> </table>	PIN	ASC0	MUX1	MUX2	MUX3	Charge		Last	●	●	●	●	●	○	○	○
PIN	ASC0	MUX1	MUX2	MUX3	Charge		Last										
●	●	●	●	●	○	○	○										

### Command Description

Read command returns the current parameters of PUC.

Write command sets the parameters of Advice of Charge related price per unit and currency table. SIM PIN2 is usually required to set the parameters.

### Parameter Description

`<currency>`<sup>(str)(+CSCS)</sup>

Three-character currency code (e.g. "GBP", "EUR"). If the currency name is longer than three characters, all characters will be cut off after the third position. Before they are written to the SIM Card, these characters are converted to the standard GSM alphabet.

`<ppu>`<sup>(str)</sup>

Price per unit; dot is used as a decimal separator (e.g. "2.66"). The length is limited to 20 characters. If the string length is exceeded, the command is terminated with an error. This string may only contain digits and a dot. Leading zeros are removed from the string. The minimum and maximum value are determined by the structure of the SIM-PUCT file. The maximum price per unit value is 999 999 999.00. When successfully entered, this value is rounded to maximum accuracy.

Note: Due to storage in mantisse (range 0-4095) and exponent (-7 to 7) it is possible that rounding errors occur.

`<passwd>`<sup>(str)</sup>

SIM PIN2. String parameter which can contain any combination of characters. The maximum string length is limited to 8 characters. If this value is exceeded, the command terminates with an error message. If the PIN2 is incorrect, a CME error (+CME ERROR: incorrect password) is output.



### Example

To change currency and/or price per unit you have two ways:

You can enter PIN2 along with the [AT+CPUC](#) command:

```
AT+CPUC="EUR", "0.10", "8888" (where "8888" = PIN2)
OK
```

Alternatively, you can first use the [AT+CPIN2](#) command to enter PIN2. When you execute the [AT+CPUC](#) command, subsequently, take into account that PIN2 authentication expires after 300ms (see notes in [AT+CPIN2](#)).

```
AT+CPUC="EUR", "0.10"
OK Successful
AT+CPUC="EUR", "0.10"
+CME ERROR: SIM PIN2 required Attempt not successful. PIN2 authentication has expired.
```

## 9.12 AT+CSSN Supplementary service notifications

### Syntax

<p>Test Command</p> <p>AT+CSSN=?</p> <p>Response(s)</p> <p>+CSSN: (list of supported&lt;n&gt;s), (list of supported&lt;m&gt;s)</p> <p>OK</p>																	
<p>Read Command</p> <p>AT+CSSN?</p> <p>Response(s)</p> <p>+CSSN: &lt;n&gt;, &lt;m&gt;</p> <p>OK</p>																	
<p>Write Command</p> <p>AT+CSSN=&lt;n&gt;[, &lt;m&gt;]</p> <p>Response(s)</p> <p>OK</p> <p>ERROR</p> <p>+CME ERROR</p>																	
<p>Reference(s)</p> <p>GSM 07.07</p>	<table border="1"> <thead> <tr> <th>PIN</th> <th>ASC0</th> <th>MUX1</th> <th>MUX2</th> <th>MUX3</th> <th>Charge</th> <th></th> <th>Last</th> </tr> </thead> <tbody> <tr> <td><input type="radio"/></td> <td><input checked="" type="radio"/></td> <td><input checked="" type="radio"/></td> <td><input checked="" type="radio"/></td> <td><input checked="" type="radio"/></td> <td><input type="radio"/></td> <td><input type="radio"/></td> <td><input type="radio"/></td> </tr> </tbody> </table>	PIN	ASC0	MUX1	MUX2	MUX3	Charge		Last	<input type="radio"/>	<input checked="" type="radio"/>	<input checked="" type="radio"/>	<input checked="" type="radio"/>	<input checked="" type="radio"/>	<input type="radio"/>	<input type="radio"/>	<input type="radio"/>
PIN	ASC0	MUX1	MUX2	MUX3	Charge		Last										
<input type="radio"/>	<input checked="" type="radio"/>	<input checked="" type="radio"/>	<input checked="" type="radio"/>	<input checked="" type="radio"/>	<input type="radio"/>	<input type="radio"/>	<input type="radio"/>										

### Unsolicited Result Codes

#### URC 1

+CSSI: <code 1>

When <n>=1 and a supplementary service notification is received after a mobile originated call setup, intermediate result code "+CSSI: <code 1>" is sent to TE before any other MO call setup result codes

#### URC 2

+CSSU: <code 2>

When <m>=1 and a supplementary service notification is received during a mobile terminated call setup or during a call, unsolicited result code "+CSSU: <code 2>" is sent to TE.

### Command Description

The write command enables or disables the presentation of URCs for supplementary services.

### Parameter Description

<n> <sup>(num)</sup>	
0(&F)	Suppress "+CSSI" URCs
1	Activate "+CSSI" URCs
<m> <sup>(num)</sup>	
0(&F)	Suppress "+CSSU" URCs
1	Activate "+CSSU" URCs

---

<code 1><sup>(num)</sup>

0	unconditional call forwarding is active
1	some of the conditional call forwardings are active
2	call has been forwarded
3	Waiting call is pending

<code 2><sup>(num)</sup>

0	The incoming call is a forwarded call.
5	Held call was terminated by other party
10	additional incoming call forwarded

**Note**

- URCs will be displayed only if the call concerned is a voice call, but some URCs will be displayed as well as for data calls (like "+CSSU"=0).

## 9.13 AT+CUSD Supplementary service notifications

This command allows control of the Unstructured Supplementary Service Data (USSD) according to GSM 02.90. Both network and mobile initiated operations are supported.

### Syntax

<p>Test Command</p> <p>AT+CUSD=?</p> <p>Response(s)</p> <p>+CUSD: (list of supported&lt;n&gt;s)</p> <p>OK</p>																	
<p>Read Command</p> <p>AT+CUSD?</p> <p>Response(s)</p> <p>+CUSD: &lt;n&gt;</p> <p>OK</p>																	
<p>Write Command</p> <p>AT+CUSD=&lt;n&gt;[, &lt;str_write&gt;[, &lt;dcs&gt;]]</p> <p>Response(s)</p> <p>OK</p> <p>+CME ERROR</p>																	
<p>Reference(s)</p> <p>GSM 07.07, GSM 02.90, GSM 03.90, GSM 04.90</p>	<table border="1"> <thead> <tr> <th>PIN</th> <th>ASC0</th> <th>MUX1</th> <th>MUX2</th> <th>MUX3</th> <th>Charge</th> <th></th> <th>Last</th> </tr> </thead> <tbody> <tr> <td>●</td> <td>●</td> <td>●</td> <td>●</td> <td>●</td> <td>○</td> <td>○</td> <td>○</td> </tr> </tbody> </table>	PIN	ASC0	MUX1	MUX2	MUX3	Charge		Last	●	●	●	●	●	○	○	○
PIN	ASC0	MUX1	MUX2	MUX3	Charge		Last										
●	●	●	●	●	○	○	○										

### Unsolicited Result Code

+CUSD: <m>[<str\_urc>[<dcs>]]

URC "+CUSD" indicates an USSD response from the network, or network initiated operation

### Command Description

The read command returns the current <n> value

Write command parameter <n> is used to disable/enable the presentation of an unsolicited result code (USSD response from the network, or network initiated operation) "+CUSD: <m>[<str\_urc>[<dcs>]]" to the TE.

When <str\_write> is given, a mobile initiated USSD string or a response USSD string to a network initiated operation is sent to the network. The response USSD string from the network is returned in a subsequent unsolicited result code "+CUSD"

The interaction of this command with other commands based on other GSM supplementary services is described in the GSM standard.

### Parameter Description

<n> <sup>(num)</sup>	
0(&F)	Disable the result code presentation in the TA
1	Enable the result code presentation in the TA
2	Cancel session (not applicable to read command response)

`<str_write>`<sup>(str)</sup>

String type USSD-string (when `<str_write>` parameter is not given, network is not interrogated).  
For the write command, only `<dcs>= 15` is supported.

`<str_urc>`<sup>(str)(+CSCS)</sup>

String type USSD-string .  
If `<dcs>` indicates that GSM 03.38 default alphabet is used TA converts GSM alphabet into current TE character set according to rules of GSM 07.05 Annex A. Otherwise in case of invalid or omitted `<dcs>` conversion of `<str_urc>` is not possible.

`<dcs>`<sup>(num)</sup>

GSM 03.38 Cell Broadcast Data Coding Scheme in integer format (default 15). In case of an invalid or omitted `<dcs>` from the network side (MT) `<dcs>` will not be given out.

`<m>`<sup>(num)</sup>

0	No further user action required (network initiated USSD-Notify, or no further information needed after mobile initiated operation)
1	Further user action required (network initiated USSD-Request, or further information needed after mobile initiated operation). If <code>&lt;m&gt;=1</code> , then the URC ends with ">" to prompt the user for input. The user action is finished with <code>&lt;CTRL-Z&gt;</code> or aborted with <code>&lt;ESC&gt;</code> .
2	USSD terminated by network.

### Notes

- When a USSD string is sent via `ATD`, a "`AT+CUSSD=1`" is executed implicitly.
- It is recommended to finalize or escape a pending USSD user interaction before further actions are done to prevent blocking situations.

## 10. FAX Commands

The following commands can be used for fax transmission.

If the ME is acting as a Fax modem for a PC based application (e.g. "WinFax") it is necessary to select the proper Service Class (Fax Class) provided by the ME. The ME reports its Service Class capabilities, both the current setting and the range of services available. This is provided by the [AT+FCLASS](#) command.

Service Classes supported by the ME:

<a href="#">AT+FCLASS</a> Parameter	Service class	Reference, Standard
0	Data modem	e.g. TIA/EIA-602 or ITU V.250
1	Service Class 1	EIA/TIA-578-A
2	Manufacturer specific	This document and EIA PN-2388 (draft)

The following AT commands are dummy commands:

AT+FAA Auto Answer mode

AT+FECM Error Correction Mode control

AT+FLNFC Page Length format conversion

AT+FLPL Indicate document available for polling

AT+FMINSF Minimum Phase C speed

AT+FRBC Phase C data receive byte count

AT+FREL Phase C received EOL alignment

AT+FSPL Enable polling

AT+FTBC Phase C data transmit byte count

AT+FWDFC Page width format conversion

Invoking these commands will not cause ERROR result codes, but these commands have no functionality.

### 10.1 FAX parameters

Below you can find a summary of parameters used by the fax-specific AT commands and responses described in this chapter. Please note that parameter `<mod>` is dedicated to Fax Class 1 only. All other parameters listed below are for Fax Class 2 only.

#### **Parameter Description**

`<mod>`<sup>(num)</sup>

Modulation scheme

To find out which value is actually supported by `<mod>` use the test commands while the ME is off-hook.

3	V21 Ch2 - 300 bps
24	V.27ter - 2400 bps
48	V.27ter - 7200 bps
72	V.29 - 7200 bps
96	V.29 - 9600 bps

`<bft>`<sup>(num)</sup>

Binary File Transfer Mode

[0]	Disable BFT
1	Enable BFT

**<br><sup>(num)</sup>**

**Bit Rate**

0	2400 bps, V.27ter
1	4800 bps, V.27ter
2	7200 bps, V.29
[3]	9600 bps, V.29

**<df><sup>(num)</sup>**

**Data Compression Format**

[0]	1-D modified Huffman
1	2-D modified read
2	2-D uncompressed mode

**<ec><sup>(num)</sup>**

**Error Correction Mode**

[0]	Disable ECM
1	Enable ECM, 64 bytes/frame
2	Enable ECM, 256 bytes/frame

**<ln><sup>(num)</sup>**

**Page Length**

0	A4, 297mm
1	B4, 364mm
[2]	Unlimited length

**<st><sup>(num)</sup>**

**Scan Time/Line**

[0]	0 ms (at VR= normal)	
1	5 s	m
2	10 s	m
3	10 s	m
4	20 s	m
5	20 s	m
6	40 s	m
7	40 s	m

**<vr><sup>(num)</sup>**

**Vertical Resolution**

0	Normal, 98 lpi
[1]	Fine, 196 lpi

<wd><sup>(num)</sup>

Page Width

[0]	1728 pixels in 215mm
1	2048 pixels in 255 mm
2	2432 pixels in 303 mm
3	1216 pixels in 151 mm
4	864 pixels in 107 mm

**Note**

- The host application is not required to support all values of the parameters listed above. Depending on the application design it may be sufficient to implement only the default values. See T.31, T.32 and EIA PN-2388 specifications for further advice.

### 10.1.1 Summary of Fax Class 2 URCs defined by EIA PN-2388

The following URCs are messages indicated in communication only. The URCs are not user definable.

**Table 10.1:** Summary of Fax Class 2 URCs defined by EIA PN-2388

URC	Meaning
+FCON	Indicates connection with a fax machine.
+FCSI: <id>	Reports the remote ID, called station ID.
+FDCS: <vr>,  , <wd>, <ln>, <df>, <ec>, <bf>, <st>	Reports current session parameters (refer to EIA PN-2388, Table 3.10).
+FDIS: <vr>,  , <wd>, <ln>, <df>, <ec>, <bf>, <st>	Reports the remote station capabilities (refer to EIA PN-2388, Table 3.10).
+FET: <stat>	Post page message. Indicates whether or not further pages or documents are pending.
+FHNG: <stat>	Reports that call has been terminated and indicates status.
+FNSF: "<param>"	Reports non-standard setup frame.
+FPTS: "<stat>"	Reports the status of received pages.
+FTSI: "<id>"	Reports the remote ID, transmit station ID.



## 10.2 AT+FBADLIN Bad Line Threshold

This command defines the Copy-Quality-OK-threshold. If `<badlin>` consecutive lines have pixel count errors in normal resolution (98 dpi) mode, then the copy quality is unacceptable. If `<badlin>` \* 2 consecutive lines have pixel count errors in fine resolution (196 dpi) mode, then the copy quality is unacceptable. "Copy Quality Not OK" occurs if either the error percentage is too high or too many consecutive lines contain errors. A value of 0 implies that error checking is not present or disabled.

### Syntax

Read Command																	
AT+FBADLIN?																	
Response(s)																	
<code>&lt;badlin&gt;</code>																	
OK																	
Write Command																	
AT+FBADLIN= <code>&lt;badlin&gt;</code>																	
Response(s)																	
OK																	
If error is related to ME functionality																	
ERROR																	
Reference(s)	<table border="1"> <tr> <td>PIN</td> <td>ASC0</td> <td>MUX1</td> <td>MUX2</td> <td>MUX3</td> <td>Charge</td> <td></td> <td>Last</td> </tr> <tr> <td><input type="radio"/></td> <td><input checked="" type="radio"/></td> <td><input checked="" type="radio"/></td> <td><input type="radio"/></td> <td><input type="radio"/></td> <td><input type="radio"/></td> <td><input type="radio"/></td> <td><input type="radio"/></td> </tr> </table>	PIN	ASC0	MUX1	MUX2	MUX3	Charge		Last	<input type="radio"/>	<input checked="" type="radio"/>	<input checked="" type="radio"/>	<input type="radio"/>	<input type="radio"/>	<input type="radio"/>	<input type="radio"/>	<input type="radio"/>
PIN	ASC0	MUX1	MUX2	MUX3	Charge		Last										
<input type="radio"/>	<input checked="" type="radio"/>	<input checked="" type="radio"/>	<input type="radio"/>	<input type="radio"/>	<input type="radio"/>	<input type="radio"/>	<input type="radio"/>										
EIA PN-2388																	

### Parameter Description

<code>&lt;badlin&gt;</code> <sup>(num)</sup>
Bad lines
0...10 <sup>(P)</sup> ...255

### Note

- Used for Fax Class 2 only.

## 10.3 AT+FBADMUL Error Threshold Multiplier

This command defines the "Copy-Quality-OK" multiplier. The number of lines received with a bad pixel count is multiplied by this number. If the result exceeds the total number of lines on the page the error rate is considered too high. A threshold multiplier value of 20 corresponds to a 5 per cent error rate. A value of 0 implies that error checking is not present or disabled.

### Syntax

Read Command	
AT+FBADMUL?	
Response(s)	
<badmul>	
OK	
Write Command	
AT+FBADMUL=<badmul>	
Response(s)	
OK	
If error is related to ME functionality:	
ERROR	
Reference(s)	
EIA PN-2388	
	PIN ASC0 MUX1 MUX2 MUX3 Charge Last
	<input type="radio"/> <input checked="" type="radio"/> <input checked="" type="radio"/> <input type="radio"/> <input type="radio"/> <input type="radio"/> <input type="radio"/> <input type="radio"/>

### Parameter Description

<badmul> <sup>(num)</sup>
0...20 <sup>(P)</sup> ...255

### Note

- Used for Fax Class 2 only.

## 10.4 AT+FBOR Query data Bit Order

This command queries the bit order for the receive mode. The mode is set by the ME depending on the selected Service Class, see "AT+FCLASS Fax: Select, read or test service class".

### Syntax

<p>Test Command</p> <p>AT+FBOR=?</p> <p>Response(s)</p> <p>(list of supported &lt;bor&gt;s)</p> <p>OK</p>																	
<p>Read Command</p> <p>AT+FBOR?</p> <p>Response(s)</p> <p>&lt;bor&gt;</p> <p>OK</p>																	
<p>Write Command</p> <p>AT+FBOR=&lt;bor&gt;</p> <p>Response(s)</p> <p>OK</p>																	
<p>Reference(s)</p> <p>EIA PN-2388</p>	<table border="1"> <thead> <tr> <th>PIN</th> <th>ASC0</th> <th>MUX1</th> <th>MUX2</th> <th>MUX3</th> <th>Charge</th> <th></th> <th>Last</th> </tr> </thead> <tbody> <tr> <td><input type="radio"/></td> <td><input checked="" type="radio"/></td> <td><input checked="" type="radio"/></td> <td><input type="radio"/></td> <td><input type="radio"/></td> <td><input type="radio"/></td> <td><input type="radio"/></td> <td><input type="radio"/></td> </tr> </tbody> </table>	PIN	ASC0	MUX1	MUX2	MUX3	Charge		Last	<input type="radio"/>	<input checked="" type="radio"/>	<input checked="" type="radio"/>	<input type="radio"/>	<input type="radio"/>	<input type="radio"/>	<input type="radio"/>	<input type="radio"/>
PIN	ASC0	MUX1	MUX2	MUX3	Charge		Last										
<input type="radio"/>	<input checked="" type="radio"/>	<input checked="" type="radio"/>	<input type="radio"/>	<input type="radio"/>	<input type="radio"/>	<input type="radio"/>	<input type="radio"/>										

### Parameter Description

<bor> <sup>(num)</sup>	
bit order modes	
0	Direct bit order for both Phase C and for Phase B/D data.
[1]	Reversed bit order for Phase C data, direct Bit Order for Phase B/D data.

### Note

- Used for Fax Class 2 only.

## 10.5 AT+FCIG Query or set the Local Polling ID

### Syntax

Test Command

```
AT+FCIG=?
```

Response(s)

(max. length of Local Polling ID string) (range of supported ASCII character values)

```
OK
```

Read Command

```
AT+FCIG?
```

Response(s)

```
<id>
```

```
OK
```

Write Command

```
AT+FCIG=<id>
```

Response(s)

```
OK
```

Reference(s)

EIA PN-2388

PIN	ASC0	MUX1	MUX2	MUX3	Charge		Last
<input type="radio"/>	<input checked="" type="radio"/>	<input checked="" type="radio"/>	<input type="radio"/>	<input type="radio"/>	<input type="radio"/>	<input type="radio"/>	<input type="radio"/>

### Parameter Description

<id><sup>(num)</sup>

Local Polling ID string, max. length and possible content as reported by test command. Default value is empty string ("").

### Notes

- Used for Fax Class 2 only.
- See also [AT+FLID](#) Query or set the Local ID setting capabilities.

## 10.6 AT+FCLASS Fax: Select, read or test service class

**AT+FCLASS** sets the ME to a particular mode of operation (data, fax). This allows the ME to process information in a manner suitable for that type of information.

### Syntax

<p>Test Command</p> <p>AT+FCLASS=?</p> <p>Response(s)</p> <p>(list of supported &lt;n&gt;s)</p> <p>OK</p>																	
<p>Read Command</p> <p>AT+FCLASS?</p> <p>Response(s)</p> <p>&lt;n&gt;</p> <p>OK</p>																	
<p>Write Command</p> <p>AT+FCLASS=&lt;n&gt;</p> <p>Response(s)</p> <p>OK</p>																	
<p>Reference(s)</p> <p>EIA/TIA-592-A</p>	<table border="1"> <thead> <tr> <th>PIN</th> <th>ASC0</th> <th>MUX1</th> <th>MUX2</th> <th>MUX3</th> <th>Charge</th> <th></th> <th>Last</th> </tr> </thead> <tbody> <tr> <td><input type="radio"/></td> <td><input checked="" type="radio"/></td> <td><input checked="" type="radio"/></td> <td><input type="radio"/></td> <td><input type="radio"/></td> <td><input type="radio"/></td> <td><input type="radio"/></td> <td><input type="radio"/></td> </tr> </tbody> </table>	PIN	ASC0	MUX1	MUX2	MUX3	Charge		Last	<input type="radio"/>	<input checked="" type="radio"/>	<input checked="" type="radio"/>	<input type="radio"/>	<input type="radio"/>	<input type="radio"/>	<input type="radio"/>	<input type="radio"/>
PIN	ASC0	MUX1	MUX2	MUX3	Charge		Last										
<input type="radio"/>	<input checked="" type="radio"/>	<input checked="" type="radio"/>	<input type="radio"/>	<input type="radio"/>	<input type="radio"/>	<input type="radio"/>	<input type="radio"/>										

### Parameter Description

<n> <sup>(num)(&amp;W)(&amp;V)</sup>	
[0] <sup>(&amp;F)</sup>	Data (e.g. EIA/TIA-602 or ITU V.250)
1	Fax class 1 (EIA/TIA-578-A, Service Class 1)
2	Fax class 2 (EIA/TIA SP-2388, an early draft version of EIA/TIA-592-A - Service class 2.1)

### Notes

- Using Error Correcting Mode (ECM) when sending FAXes over GSM should be avoided.
- If <n> is set to 1 or 2, all incoming calls will be answered as fax calls when **ATA** is issued on multiplexer channel 1 resp. ASC0. For calls explicitly signaled as voice or data calls, this procedure will fail with result code "NO CARRIER", but the incoming call will continue to ring. It is possible to change the setting of <n> to 0 while the call is ringing, and accept the call afterwards with **ATA**. In automatic answer mode (setting of **ATS0** is different from 0) a voice call will be established automatically regardless of the setting of <n>.

## 10.7 AT+FCQ Copy Quality Checking

This command controls Copy Quality checking when receiving a fax.

### Syntax

<p>Test Command</p> <p>AT+FCQ=?</p> <p>Response(s)</p> <p>(list of supported copy quality checking &lt;cq&gt;s)</p> <p>OK</p>																	
<p>Read Command</p> <p>AT+FCQ?</p> <p>Response(s)</p> <p>&lt;cq&gt;</p> <p>OK</p>																	
<p>Write Command</p> <p>AT+FCQ=&lt;cq&gt;</p> <p>Response(s)</p> <p>OK</p>																	
<p>Reference(s)</p> <p>EIA PN-2388</p>	<table border="1"> <thead> <tr> <th>PIN</th> <th>ASC0</th> <th>MUX1</th> <th>MUX2</th> <th>MUX3</th> <th>Charge</th> <th></th> <th>Last</th> </tr> </thead> <tbody> <tr> <td><input type="radio"/></td> <td><input checked="" type="radio"/></td> <td><input checked="" type="radio"/></td> <td><input type="radio"/></td> <td><input type="radio"/></td> <td><input type="radio"/></td> <td><input type="radio"/></td> <td><input type="radio"/></td> </tr> </tbody> </table>	PIN	ASC0	MUX1	MUX2	MUX3	Charge		Last	<input type="radio"/>	<input checked="" type="radio"/>	<input checked="" type="radio"/>	<input type="radio"/>	<input type="radio"/>	<input type="radio"/>	<input type="radio"/>	<input type="radio"/>
PIN	ASC0	MUX1	MUX2	MUX3	Charge		Last										
<input type="radio"/>	<input checked="" type="radio"/>	<input checked="" type="radio"/>	<input type="radio"/>	<input type="radio"/>	<input type="radio"/>	<input type="radio"/>	<input type="radio"/>										

### Parameter Description

<cq> <sup>(num)</sup>	Description
0	No copy quality checking. The ME will generate Copy Quality OK (MCF) responses to complete pages.
[1]	ME can check 1-D phase data. The connected application must check copy quality for 2-D phase C data.

### Note

- Used for Fax Class 2 only.

## 10.8 AT+FCR Capability to Receive

### Syntax

Write Command	
AT+FCR=<cr>	
Response(s)	
OK	
Reference(s)	PIN ASC0 MUX1 MUX2 MUX3 Charge  Last
EIA PN-2388	<input type="radio"/> <input checked="" type="radio"/> <input checked="" type="radio"/> <input type="radio"/> <input type="radio"/> <input type="radio"/> <input type="radio"/> <input type="radio"/>

### Parameter Description

<cr> <sup>(num)</sup>	
[0]	ME will not receive message data. This value can be used when the application has insufficient storage. The ME can send and can be polled for a file.
1	ME can receive message data.



### Note

- Used for Fax Class 2 only.

## 10.9 AT+FDCC Query or set capabilities

This command allows the connected application to sense and constrain the capabilities of the facsimile DCE (=ME), from the choices defined in CCITT T.30 Table 2.

### Syntax

<p>Test Command</p> <p>AT+FDCC=?</p> <p>Response(s)</p> <p>(list of &lt;vr&gt;s), (list of &lt;br&gt;s), (list of &lt;wd&gt;s), (list of &lt;ln&gt;s), (list of &lt;df&gt;s), (list of &lt;ec&gt;s), (list of &lt;bf&gt;s), (list of &lt;st&gt;s)</p> <p>OK</p>																	
<p>Read Command</p> <p>AT+FDCC?</p> <p>Response(s)</p> <p>&lt;vr&gt;, &lt;br&gt;, &lt;wd&gt;, &lt;ln&gt;, &lt;df&gt;, &lt;ec&gt;, &lt;bf&gt;, &lt;st&gt;</p> <p>OK</p>																	
<p>Write Command</p> <p>AT+FDCC=&lt;vr&gt;, &lt;br&gt;, &lt;wd&gt;, &lt;ln&gt;, &lt;df&gt;, &lt;ec&gt;, &lt;bf&gt;, &lt;st&gt;</p> <p>Response(s)</p> <p>OK</p>																	
<p>Reference(s)</p> <p>EIA PN-2388</p>	<table border="1"> <thead> <tr> <th>PIN</th> <th>ASC0</th> <th>MUX1</th> <th>MUX2</th> <th>MUX3</th> <th>Charge</th> <th></th> <th>Last</th> </tr> </thead> <tbody> <tr> <td><input type="radio"/></td> <td><input checked="" type="radio"/></td> <td><input checked="" type="radio"/></td> <td><input type="radio"/></td> <td><input type="radio"/></td> <td><input type="radio"/></td> <td><input type="radio"/></td> <td><input type="radio"/></td> </tr> </tbody> </table>	PIN	ASC0	MUX1	MUX2	MUX3	Charge		Last	<input type="radio"/>	<input checked="" type="radio"/>	<input checked="" type="radio"/>	<input type="radio"/>	<input type="radio"/>	<input type="radio"/>	<input type="radio"/>	<input type="radio"/>
PIN	ASC0	MUX1	MUX2	MUX3	Charge		Last										
<input type="radio"/>	<input checked="" type="radio"/>	<input checked="" type="radio"/>	<input type="radio"/>	<input type="radio"/>	<input type="radio"/>	<input type="radio"/>	<input type="radio"/>										

### Notes



- For further information see [AT+FDIS](#).
- Used for Fax Class 2 only.



## 10.10 AT+FDFFC Data Compression Format Conversion

This command determines the ME response to a mismatch between the data format negotiated for the fax session, reported by the `<df>` subparameter, and the Phase C data desired by the controlling application, indicated by the optional `AT+FDT <df>` subparameter, or the `AT+FDIS <df>` subparameter for `AT+FDR` operation.

### Syntax

<p>Test Command</p> <p>AT+FDFFC=?</p> <p>Response(s)</p> <p>(list of <code>&lt;df&gt;</code>s)</p> <p>OK</p>																	
<p>Read Command</p> <p>AT+FDFFC?</p> <p>Response(s)</p> <p><code>&lt;df&gt;</code></p> <p>OK</p>																	
<p>Write Command</p> <p>AT+FDFFC=&lt;df&gt;</p> <p>Response(s)</p> <p>OK</p>																	
<p>Reference(s)</p> <p>EIA PN-2388</p>	<table border="1"> <thead> <tr> <th>PIN</th> <th>ASC0</th> <th>MUX1</th> <th>MUX2</th> <th>MUX3</th> <th>Charge</th> <th></th> <th>Last</th> </tr> </thead> <tbody> <tr> <td><input type="radio"/></td> <td><input checked="" type="radio"/></td> <td><input checked="" type="radio"/></td> <td><input type="radio"/></td> <td><input type="radio"/></td> <td><input type="radio"/></td> <td><input type="radio"/></td> <td><input type="radio"/></td> </tr> </tbody> </table>	PIN	ASC0	MUX1	MUX2	MUX3	Charge		Last	<input type="radio"/>	<input checked="" type="radio"/>	<input checked="" type="radio"/>	<input type="radio"/>	<input type="radio"/>	<input type="radio"/>	<input type="radio"/>	<input type="radio"/>
PIN	ASC0	MUX1	MUX2	MUX3	Charge		Last										
<input type="radio"/>	<input checked="" type="radio"/>	<input checked="" type="radio"/>	<input type="radio"/>	<input type="radio"/>	<input type="radio"/>	<input type="radio"/>	<input type="radio"/>										

### Parameter Description

<code>&lt;df&gt;</code> <sup>(num)</sup>	Description
[0]	Mismatch checking is always disabled. The controlling application has to check the <code>&lt;df&gt;</code> subparameter and transfer matching data.



### Notes

- For further information see [AT+FDIS](#).
- Used for Fax Class 2 only.

## 10.11 AT+FDIS Query or set session parameters

This command allows the controlling application to sense and constrain the capabilities used for the current session. It uses [AT+FDIS](#) to generate DIS or DTC messages directly, and uses [AT+FDIS](#) and received DIS messages to generate DCS messages.

### Syntax

<p>Test Command</p> <p>AT+FDIS=?</p> <p>Response(s)</p> <p>(list of &lt;vr&gt;s), (list of &lt;br&gt;s), (list of &lt;wd&gt;s), (list of &lt;ln&gt;s), (list of &lt;df&gt;s), (list of &lt;ec&gt;s), (list of &lt;bf&gt;s), (list of &lt;st&gt;s)</p> <p>OK</p>																	
<p>Read Command</p> <p>AT+FDIS?</p> <p>Response(s)</p> <p>&lt;vr&gt;, &lt;br&gt;, &lt;wd&gt;, &lt;ln&gt;, &lt;df&gt;, &lt;ec&gt;, &lt;bf&gt;, &lt;st&gt;</p> <p>OK</p>																	
<p>Write Command</p> <p>AT+FDIS=&lt;vr&gt;, &lt;br&gt;, &lt;wd&gt;, &lt;ln&gt;, &lt;df&gt;, &lt;ec&gt;, &lt;bf&gt;, &lt;st&gt;</p> <p>Response(s)</p> <p>OK</p>																	
<p>Reference(s)</p> <p>EIA PN-2388</p>	<table border="1"> <thead> <tr> <th>PIN</th> <th>ASC0</th> <th>MUX1</th> <th>MUX2</th> <th>MUX3</th> <th>Charge</th> <th></th> <th>Last</th> </tr> </thead> <tbody> <tr> <td><input type="radio"/></td> <td><input checked="" type="radio"/></td> <td><input checked="" type="radio"/></td> <td><input type="radio"/></td> <td><input type="radio"/></td> <td><input type="radio"/></td> <td><input type="radio"/></td> <td><input type="radio"/></td> </tr> </tbody> </table>	PIN	ASC0	MUX1	MUX2	MUX3	Charge		Last	<input type="radio"/>	<input checked="" type="radio"/>	<input checked="" type="radio"/>	<input type="radio"/>	<input type="radio"/>	<input type="radio"/>	<input type="radio"/>	<input type="radio"/>
PIN	ASC0	MUX1	MUX2	MUX3	Charge		Last										
<input type="radio"/>	<input checked="" type="radio"/>	<input checked="" type="radio"/>	<input type="radio"/>	<input type="radio"/>	<input type="radio"/>	<input type="radio"/>	<input type="radio"/>										

### Note

- Used for Fax Class 2 only.

## 10.12 AT+FDR Begin or continue phase C Data Reception

The command initiates transition to Phase C data reception.

### Syntax

Exec Command								
AT+FDR								
Response(s)								
CONNECT								
or								
OK								
If error related to ME functionality								
ERROR								
Reference(s)	PIN	ASC0	MUX1	MUX2	MUX3	Charge		Last
EIA PN-2388	<input type="radio"/>	<input checked="" type="radio"/>	<input checked="" type="radio"/>	<input type="radio"/>	<input type="radio"/>	<input type="radio"/>	<input type="radio"/>	<input type="radio"/>

### Note

- Used for Fax Class 2 only.

## 10.13 AT+FDT Data Transmission

This command requests the ME to transmit a Phase C page. When the ME is ready to accept Phase C data, it issues the negotiation responses and the CONNECT result code to the application. In Phase B, the `AT+FDT` command releases the ME to proceed with negotiation, and releases the DCS message to the remote station. In Phase C, the `AT+FDT` command resumes transmission after the end of a data stream transmitted before.

### Syntax

Exec Command									
AT+FDT									
Response(s)									
CONNECT									
Write Command									
AT+FDT=<df>, <vr>, <wd>, <ln>									
Response(s)									
CONNECT									
Reference(s)		PIN	ASC0	MUX1	MUX2	MUX3	Charge		Last
EIA PN-2388		<input type="radio"/>	<input checked="" type="radio"/>	<input checked="" type="radio"/>	<input type="radio"/>	<input type="radio"/>	<input type="radio"/>	<input type="radio"/>	<input type="radio"/>

### Note

- Used for Fax Class 2 only.

## 10.14 AT+FET End a page or document

This command indicates that the current page or partial page is complete. An ERROR response code results if this command is issued while the mode is on-hook.

### Syntax

Write Command										
AT+FET=<ppm>										
Response(s)										
OK										
Reference(s)										
EIA PN-2388			PIN	ASC0	MUX1	MUX2	MUX3	Charge	🔔	Last
			○	●	●	○	○	○	○	○

### Parameter Description

<ppm> <sup>(num)</sup>	
Post Page Message Codes	
1	Another document next
2	No more pages or documents
4	Another page, procedure interrupt
5	Another document, procedure interrupt

### Note

- Used for Fax Class 2 only.

## 10.15 AT+FK Kill operation, orderly FAX abort

This command causes the TA to terminate the session in an orderly manner.

### Syntax

Exec Command
AT+FK
Response(s)
OK

PIN	ASC0	MUX1	MUX2	MUX3	Charge		Last
<input type="radio"/>	<input checked="" type="radio"/>	<input checked="" type="radio"/>	<input type="radio"/>	<input type="radio"/>	<input type="radio"/>	<input type="radio"/>	<input type="radio"/>

### Note

- Used for Fax Class 2 only

## 10.16 AT+FLID Query or set the Local Id setting capabilities

### Syntax

Test Command	
AT+FLID=?	
Response(s)	(max. character length of Local ID string) (range of supported ASCII character values)
	OK
Read Command	
AT+FLID?	
Response(s)	<lid>
	OK
Write Command	
AT+FLID=<lid>	
Response(s)	
	OK
Reference(s)	
EIA PN-2388	

PIN	ASC0	MUX1	MUX2	MUX3	Charge		Last
<input type="radio"/>	<input checked="" type="radio"/>	<input checked="" type="radio"/>	<input type="radio"/>	<input type="radio"/>	<input type="radio"/>	<input type="radio"/>	<input type="radio"/>

### Parameter Description

<lid><sup>(num)</sup>  
Local ID string  
Max. length and possible content as reported by test command. Default value is empty string ("").

### Notes

- Used for Fax Class 2 only.
- See also [AT+FCIG](#).

## 10.17 AT+FMDL Identify Product Model

This command sends the model identification to the TA.

### Syntax

Read Command								
AT+FMDL?								
Response(s)								
Gipsy Soft Protocolstack OK								
Reference(s)	PIN	ASC0	MUX1	MUX2	MUX3	Charge		Last
--	<input type="radio"/>	<input checked="" type="radio"/>	<input checked="" type="radio"/>	<input type="radio"/>	<input type="radio"/>	<input type="radio"/>	<input type="radio"/>	<input type="radio"/>

### Note

- Used for Fax Class 2 only.



## 10.18 AT+FMFR Request Manufacturer Identification

This command sends the manufacturer identification to the TA.

### Syntax

Read Command								
AT+FMFR?								
Response(s)								
OK								
Reference(s)	PIN	ASC0	MUX1	MUX2	MUX3	Charge		Last
--	<input type="radio"/>	<input checked="" type="radio"/>	<input checked="" type="radio"/>	<input type="radio"/>	<input type="radio"/>	<input type="radio"/>	<input type="radio"/>	<input type="radio"/>

### Note

- Used for Fax Class 2 only

## 10.19 AT+FOPT Set bit Order independently

Model specific command to set bit order independently of the understanding which is "mirrored" and which is direct.

### Syntax

Write Command							
AT+FOPT=<opt>							
Response(s)							
OK							
Reference(s)	PIN	ASC0	MUX1	MUX2	MUX3	Charge	Last
--	<input type="radio"/>	<input checked="" type="radio"/>	<input checked="" type="radio"/>	<input type="radio"/>	<input type="radio"/>	<input type="radio"/>	<input type="radio"/>

### Parameter Description

<opt> <sup>(num)</sup>	
0	Non-standard
1	Standard

### Note

- Used for Fax Class 2 only.

## 10.20 AT+FPHCTO DTE Phase C Response Timeout

The timeout value `<tout>` determines how long the DCE will wait for a command after reaching the end of data when transmitting in Phase C. When timeout is reached, the DCE assumes that there are no more pages or documents to send.

### Syntax

Read Command																	
AT+FPHCTO?																	
Response(s)																	
<code>&lt;tout&gt;</code>																	
OK																	
Write Command																	
AT+FPHCTO= <code>&lt;tout&gt;</code>																	
Response(s)																	
OK																	
If error is related to ME functionality																	
ERROR																	
Reference(s)																	
EIA PN-2388																	
	<table border="1"> <tr> <td>PIN</td> <td>ASC0</td> <td>MUX1</td> <td>MUX2</td> <td>MUX3</td> <td>Charge</td> <td></td> <td>Last</td> </tr> <tr> <td><input type="radio"/></td> <td><input checked="" type="radio"/></td> <td><input checked="" type="radio"/></td> <td><input type="radio"/></td> <td><input type="radio"/></td> <td><input type="radio"/></td> <td><input type="radio"/></td> <td><input type="radio"/></td> </tr> </table>	PIN	ASC0	MUX1	MUX2	MUX3	Charge		Last	<input type="radio"/>	<input checked="" type="radio"/>	<input checked="" type="radio"/>	<input type="radio"/>	<input type="radio"/>	<input type="radio"/>	<input type="radio"/>	<input type="radio"/>
PIN	ASC0	MUX1	MUX2	MUX3	Charge		Last										
<input type="radio"/>	<input checked="" type="radio"/>	<input checked="" type="radio"/>	<input type="radio"/>	<input type="radio"/>	<input type="radio"/>	<input type="radio"/>	<input type="radio"/>										

### Parameter Description

<code>&lt;tout&gt;</code> <sup>(num)</sup>
Timeout
Value in 100ms units
0...30 <sup>(P)</sup> ...255

### Note

- Used for Fax Class 2 only.

## 10.21 AT+FREV Identify Product Revision

This command sends the revision identification to the TA.

### Syntax

Read Command							
AT+FREV?							
Response(s)							
V2.550							
OK							
Reference(s)							
--							
PIN	ASC0	MUX1	MUX2	MUX3	Charge		Last
<input type="radio"/>	<input checked="" type="radio"/>	<input checked="" type="radio"/>	<input type="radio"/>	<input type="radio"/>	<input type="radio"/>	<input type="radio"/>	<input type="radio"/>

### Note

- Used for Fax Class 2 only.

## 10.22 AT+FRH Receive Data Using HDLC Framing

The [AT+FRH](#) command enables the TA to receive frames using the HDLC protocol and the modulation schemes defined in Section 10.1, [FAX parameters](#). An ERROR response code results if the command is issued while the modem is on-hook. The test command can be used in off-hook mode to check the modulation schemes supported by TC35i.

### Syntax

Test Command	
AT+FRH=?	
Response(s)	
In off-hook mode only: +FRH: (list of <mod>s) OK	
In on-hook mode: ERROR	
Write Command	
AT+FRH=<mod>	
Response(s)	
CONNECT If error is related to ME functionality ERROR	
Reference(s)	
TIA/EIA-578	
	PIN ASC0 MUX1 MUX2 MUX3 Charge  Last
	<input type="radio"/> <input checked="" type="radio"/> <input checked="" type="radio"/> <input type="radio"/> <input type="radio"/> <input type="radio"/> <input type="radio"/> <input type="radio"/>

### Note



- Used for Fax Class 1 only.

## 10.23 AT+FRM Receive Data

The [AT+FRM](#) command causes the TA to enter the receive mode, using one of the modulation schemes defined in Section 10.1, [FAX parameters](#).

An ERROR response code results if the write command is issued while the modem is on-hook. The test command can be used in on-hook or off-hook mode to check the modulation schemes supported by TC35i.

### Syntax

<p>Test Command</p> <p>AT+FRM=?</p> <p>Response(s)</p> <p>(list of &lt;mod&gt;s)</p> <p>OK</p>																	
<p>Write Command</p> <p>AT+FRM=&lt;mod&gt;</p> <p>Response(s)</p> <p>CONNECT</p> <p>If error is related to ME functionality:</p> <p>ERROR</p>																	
<p>Reference(s)</p> <p>TIA/EIA-578</p>	<table border="1"> <thead> <tr> <th>PIN</th> <th>ASC0</th> <th>MUX1</th> <th>MUX2</th> <th>MUX3</th> <th>Charge</th> <th></th> <th>Last</th> </tr> </thead> <tbody> <tr> <td><input type="radio"/></td> <td><input checked="" type="radio"/></td> <td><input checked="" type="radio"/></td> <td><input type="radio"/></td> <td><input type="radio"/></td> <td><input type="radio"/></td> <td><input type="radio"/></td> <td><input type="radio"/></td> </tr> </tbody> </table>	PIN	ASC0	MUX1	MUX2	MUX3	Charge		Last	<input type="radio"/>	<input checked="" type="radio"/>	<input checked="" type="radio"/>	<input type="radio"/>	<input type="radio"/>	<input type="radio"/>	<input type="radio"/>	<input type="radio"/>
PIN	ASC0	MUX1	MUX2	MUX3	Charge		Last										
<input type="radio"/>	<input checked="" type="radio"/>	<input checked="" type="radio"/>	<input type="radio"/>	<input type="radio"/>	<input type="radio"/>	<input type="radio"/>	<input type="radio"/>										

### Notes

- Used for Fax Class 1 only.
- <mod>= 3 is not possible.

## 10.24 AT+FRS Receive Silence

`<time>=n` causes the TA to report an OK result code to the TE after the specified period of silence was detected on the line.

The command is aborted if any character is received by the TE. The modem discards the aborting character and issues an OK result code. An ERROR response code results if this command is issued while the mode is on-hook.

### Syntax

Write Command									
AT+FRS=<time>									
Response(s)									
OK									
If error is related to ME functionality:									
ERROR									
Reference(s)		PIN	ASC0	MUX1	MUX2	MUX3	Charge	🔔	Last
TIA/EIA-578		<input type="radio"/>	<input checked="" type="radio"/>	<input checked="" type="radio"/>	<input type="radio"/>	<input type="radio"/>	<input type="radio"/>	<input type="radio"/>	<input type="radio"/>

### Parameter Description

<code>&lt;time&gt;</code> <sup>(num)</sup>
Number of 10 millisecond intervals
0...255

### Note

- Used for Fax Class 1 only

## 10.25 AT+FTH Transmit Data Using HDLC Framing

The [AT+FTH](#) command causes the TA to transmit data using the HDLC protocol and the modulation schemes defined in Section 10.1, [FAX parameters](#). An ERROR response code results if the command is issued while the modem is on-hook. The test command can be used in off-hook mode to check the modulation schemes supported by TC35i.

### Syntax

Test Command	
AT+FTH=?	
Response(s)	
In off-hook mode only: +FTH:(list of <mod>s) OK	
In on-hook mode: ERROR	
Write Command	
AT+FTH=<mod>	
Response(s)	
CONNECT	
Reference(s)	
TIA/EIA-578	
	PIN ASC0 MUX1 MUX2 MUX3 Charge  Last
	<input type="radio"/> <input checked="" type="radio"/> <input checked="" type="radio"/> <input type="radio"/> <input type="radio"/> <input type="radio"/> <input type="radio"/> <input type="radio"/>

### Note

- Used for Fax Class 1 only



## 10.26 AT+FTM Transmit Data

The [AT+FTM](#) command causes the TA to transmit data, using one of the modulation schemes defined in Section 10.1, [FAX parameters](#).

An ERROR response code results if the write command is issued while the modem is on-hook. The test command can be used in on-hook or off-hook mode to check the modulation schemes supported by TC35i.

### Syntax

Test Command	
AT+FTM=?	
Response(s)	
(list of <mod>s)	
OK	
Write Command	
AT+FTM=<mod>	
Response(s)	
CONNECT	
If error is related to ME functionality:	
ERROR	
Reference(s)	PIN ASC0 MUX1 MUX2 MUX3 Charge  Last
TIA/EIA-578	<input type="radio"/> <input checked="" type="radio"/> <input checked="" type="radio"/> <input type="radio"/> <input type="radio"/> <input type="radio"/> <input type="radio"/> <input type="radio"/>

### Notes

- Used for Fax Class 1 only.
- <mod>= 3 is not possible

## 10.27 AT+FTS Stop Transmission and Wait

This command causes the TA to terminate a transmission and wait for `<time>` 10 millisecond intervals before sending the OK result code to the TE.

### Syntax

Write Command									
AT+FTS=<time>									
Response(s)									
OK									
In on-hook mode:									
ERROR									
Reference(s)		PIN	ASC0	MUX1	MUX2	MUX3	Charge		Last
TIA/EIA-578		<input type="radio"/>	<input checked="" type="radio"/>	<input checked="" type="radio"/>	<input type="radio"/>	<input type="radio"/>	<input type="radio"/>	<input type="radio"/>	<input type="radio"/>

### Parameter Description

<time> <sup>(num)</sup>
no. of 10 millisecond intervals
0...85



### Note

- Used for Fax Class 1 only

## 10.28 AT+FVRF Vertical Resolution Format Conversion

This command determines the DCE response to a mismatch between the vertical resolution negotiated for the facsimile session and the Phase C data desired by the DTE.

### Syntax

<p>Test Command</p> <p>AT+FVRF=?</p> <p>Response(s)</p> <p>(list of supported &lt;vrfc&gt;s)</p> <p>OK</p>																	
<p>Read Command</p> <p>AT+FVRF?</p> <p>Response(s)</p> <p>&lt;vrfc&gt;</p> <p>OK</p>																	
<p>Write Command</p> <p>AT+FVRF=&lt;vrfc&gt;</p> <p>Response(s)</p> <p>OK</p>																	
<p>Reference(s)</p> <p>EIA PN-2388</p>	<table border="1"> <thead> <tr> <th>PIN</th> <th>ASC0</th> <th>MUX1</th> <th>MUX2</th> <th>MUX3</th> <th>Charge</th> <th></th> <th>Last</th> </tr> </thead> <tbody> <tr> <td><input type="radio"/></td> <td><input checked="" type="radio"/></td> <td><input checked="" type="radio"/></td> <td><input type="radio"/></td> <td><input type="radio"/></td> <td><input type="radio"/></td> <td><input type="radio"/></td> <td><input type="radio"/></td> </tr> </tbody> </table>	PIN	ASC0	MUX1	MUX2	MUX3	Charge		Last	<input type="radio"/>	<input checked="" type="radio"/>	<input checked="" type="radio"/>	<input type="radio"/>	<input type="radio"/>	<input type="radio"/>	<input type="radio"/>	<input type="radio"/>
PIN	ASC0	MUX1	MUX2	MUX3	Charge		Last										
<input type="radio"/>	<input checked="" type="radio"/>	<input checked="" type="radio"/>	<input type="radio"/>	<input type="radio"/>	<input type="radio"/>	<input type="radio"/>	<input type="radio"/>										

### Parameter Description

<vrfc> <sup>(num)</sup>	Description
0	Disable mismatch checking.
[2]	Enable mismatch checking, with resolution conversion of 1-D data in the DCE, and an implied AT+FK command executed on 2-D mismatch detection.

### Note

- Used for Fax Class 2 only.

## 11. Short Message Service (SMS) Commands

The AT Commands described in this chapter allow an external application to use the Short Message Service with the TC35i.

### 11.1 SMS parameters

#### Parameter Description

`<ackpdu>`<sup>(num)</sup>

Format is same for `<pdu>` in case of SMS, but without GSM 24.11 SC address field and parameter shall be bounded by double quote characters like a normal string type parameter

`<alpha>`<sup>(str)(+CSCS)</sup>

String type alphanumeric representation of `<da>` or `<oa>` corresponding to the entry found in phonebook; implementation of this feature is manufacturer specific

`<cdata>`<sup>(num)</sup>

Command Data

GSM 03.40 TP-Command-Data in text mode responses; ME/TA converts each 8-bit octet into two IRA character long hexadecimal numbers (e.g. octet with integer value 42 is presented to TE as two characters 2A (IRA 50 and 65))

`<ct>`<sup>(num)</sup>

Command Type

GSM 03.40 TP-Command-Type in integer format

[0]...255

`<da>`<sup>(num)(+CSCS)</sup>

Destination Address

GSM 03.40 TP- Destination-Address Address-Value field in string format; BCD numbers (or GSM default alpha-numeric characters) are converted into characters; type of address given by `<toda>`

`<data>`<sup>(num)(+CSCS)</sup>

User Data

In case of SMS: GSM 03.40 TP-User-Data in text mode responses; format:

- If `<dc>` indicates that GSM 03.38 default alphabet is used and `<fo>` indicates that GSM 03.40 TP-User-Data-Header-Indication is not set: ME/TA converts GSM alphabet into current TE character set according to rules covered in Annex A.
- If `<dc>` indicates that 8-bit or UCS2 data coding scheme is used, or `<fo>` indicates that GSM 03.40 TP-User-Data-Header-Indication is set: ME/TA converts each 8-bit octet into hexadecimal numbers containing two IRA characters (e.g. octet with integer value 42 is presented to TE as two characters 2A (IRA 50 and 65)).

In case of CBS: GSM 03.41 CBM Content of Message in text mode responses; format:

- If `<dc>` indicates that GSM 03.38 default alphabet is used: ME/TA converts GSM alphabet into current TE character set according to rules covered in Annex A.
- If `<dc>` indicates that 8-bit or UCS2 data coding scheme is used: ME/TA converts each 8-bit octet into hexadecimal numbers containing two IRA characters.

**<dt>**<sup>(num)</sup>

Discharge Time

GSM 03.40 TP-Discharge-Time in time-string format: "yy/MM/dd,hh:mm:ss+zz", where characters indicate year (two last digits), month, day, hour, minutes, seconds and time zone. For example, 6th of May 1994, 22:10:00 GMT+2 hours equals "94/05/06,22:10:00+08"

**<ieia>**<sup>(num)</sup>

IEIa (Information Element Identifier octet) of the concatenated SMS.

8	Concatenated short messages, 8-bit reference number
16	Concatenated short messages, 16-bit reference number

**<index>**<sup>(num)</sup>

Integer type; value in the range of location numbers supported by the associated memory

**<length>**<sup>(num)</sup>

Message Length

Integer type value indicating in the text mode (**AT+CMGF=1**) the length of the message body **<data>** (or **<cdata>**) in characters; or in PDU mode (**AT+CMGF=0**), the length of the actual TP data unit in octets (i.e. the RP layer SMSC address octets are not counted in the length) In text mode, the maximum length of an SMS depends on the used coding scheme: It is 160 characters if the 7 bit GSM coding scheme is used, and 140 characters according to the 8 bit GSM coding scheme.

If the SMS message format is "text mode" (**AT+CMGF=1**) and the character set is set to "UCS2" with **AT+CSCS** and the SMS is also coded as "UCS2" (see **<dcs>** of **AT+CSMP**), then the length is in octets instead of characters.

For concatenated SMS messages the maximum length will be reduced by the length of the user data header with respect to **<ieia>** (6 bytes for **<ieia>=8** and 7 bytes for **<ieia>=16**). In the case of 8-bit data, the maximum length of the short message field is: 140 octets - (6 or 7) = 134 or 133. In the case of GSM 7 bit default alphabet data, the maximum length of the short message is  $(140 - (6 \text{ or } 7)) * 8/7 = 153 \text{ or } 152$  characters. In the case of 16 bit UC2 data, the maximum length of the short message is:  $(140 - (6 \text{ or } 7))/2 = 67 \text{ or } 66$  characters.

**<max>**<sup>(num)</sup>

Maximum number of all segments to be concatenated into one SMS, beginning with 1.  
**<max>=0** means: ignore the value. This will result in a non-concatenated SMS.

0...255

**<mem1>**<sup>(str)</sup>

Memory to be used when listing, reading and deleting messages:

"SM" <sup>(D)</sup>	SIM message storage
"ME"	Mobile Equipment message storage
"MT"	Sum of "SM" and "ME" storages

**<mem2>**<sup>(str)</sup>

Memory to be used when writing and sending messages:

"SM" <sup>(D)</sup>	SIM message storage
"ME"	Mobile Equipment message storage
"MT"	Sum of "SM" and "ME" storages



`<ref>(num)`

Reference number to identify all segments of the concatenated SMS (i.e. the number needs to be the same for each segment). If `<ieia>=8` then max=255, otherwise 65535.

0...255

0...65535

`<sca>(num)(+CSCS)`

Service Center Address

GSM 04.11 RP SC address Address-Value field in string format; BCD numbers (or GSM default alphabet characters) are converted to characters of the currently selected TE character set (refer to command `AT+CSCS`); type of address given by `<tosca>`

`<scts>(num)`

Service Centre Time Stamp

GSM 03.40 TP-Service-Centre-Time-Stamp in time-string format (refer `<dt>`)

`<seq>(num)`

Sequence number of the concatenated SMS beginning with 1. The number must be incremented by one for each segment of the concatenated short message.

`<seq>=0` means: ignore the value. This will result in a non-concatenated SMS.

0...255

`<sn>(num)`

Serial Number

GSM 03.41 CBM Serial Number in integer format

`<st>(num)`

Status

GSM 03.40 TP-Status in integer format

0...255

`<stat>(str)`

Message status

3GPP 27.005 Interface of SMS and CB. Indicates the status of message in memory.

Description	text mode ( <code>&lt;mode&gt;=1</code> )	PDU mode ( <code>&lt;mode&gt;=0</code> )	Default
Received unread messages	"REC UNREAD"	0	for SMS reading commands
Received read messages	"REC READ"	1	
Stored unsent messages	"STO UNSENT"	2	for SMS writing commands
Stored sent messages	"STO SENT"	3	
All messages	"ALL"	4	

<todoa><sup>(num)</sup>

Type of Destination Address

GSM 04.11 TP-Destination-Address Type-of-Address octet in integer format (when first character of <da> is + (IRA 43) default is 145, otherwise default is 129)

0...255

<tooa><sup>(num)</sup>

Type of Originating Address

GSM 04.11 TP-Originating-Address Type-of-Address octet in integer format (default refer <todoa>)

<tora><sup>(num)</sup>

Type of Recipient Address

GSM 04.11 TP-Recipient-Address Type-of-Address octet in integer format (default refer <todoa>)

<tosca><sup>(num)</sup>



Type of Service Center Address

GSM 04.11 RP SC address Type-of-Address octet in integer format (default refer <todoa>)



## 11.2 AT+CMGC Send an SMS command

### Syntax

<p>Test Command</p> <p>AT+CMGC=?</p> <p>Response(s)</p> <p>OK</p>																	
<p>Write Command</p> <p>If text mode (see <a href="#">AT+CMGF=1</a>)</p> <p>AT+CMGC=&lt;fo&gt;, &lt;ct&gt;[, &lt;pid&gt;[, &lt;mn&gt;[, &lt;da&gt;[, &lt;toda&gt;]]]]&lt;CR&gt; Text can be entered &lt;CTRL-Z&gt;/&lt;ESC&gt;</p> <p>Response(s)</p> <p>+CMGC: &lt;mr&gt;[, &lt;scts&gt;]</p> <p>If sending fails</p> <p>ERROR</p> <p>+CMS ERROR</p>																	
<p>Write Command</p> <p>If PDU mode (see <a href="#">AT+CMGF=0</a>)</p> <p>AT+CMGC=&lt;length&gt;&lt;CR&gt; PDU can be entered &lt;CTRL-Z&gt;/&lt;ESC&gt;</p> <p>Response(s)</p> <p>+CMGC: &lt;mr&gt;[, &lt;ackpdu&gt;]</p> <p>OK</p> <p>If sending fails</p> <p>ERROR</p> <p>+CMS ERROR</p>																	
<p>Reference(s)</p> <p>GSM 07.05</p>	<table border="1"> <thead> <tr> <th>PIN</th> <th>ASC0</th> <th>MUX1</th> <th>MUX2</th> <th>MUX3</th> <th>Charge</th> <th></th> <th>Last</th> </tr> </thead> <tbody> <tr> <td>●</td> <td>●</td> <td>●</td> <td>●</td> <td>●</td> <td>○</td> <td>○</td> <td>○</td> </tr> </tbody> </table>	PIN	ASC0	MUX1	MUX2	MUX3	Charge		Last	●	●	●	●	●	○	○	○
PIN	ASC0	MUX1	MUX2	MUX3	Charge		Last										
●	●	●	●	●	○	○	○										

### Notes

- After invoking the commands [AT+CMGW](#), [AT+CMGS](#) or [AT+CMGC](#) it is necessary to wait for the prompt ">" before entering text or PDU. After the prompt a timer will be started to observe the input.
- At baudrates below 19200 it is recommended to use the line termination character only (refer to [ATS3](#), default <CR>) before entering the text or PDU. Use of the line termination character followed by the response formatting character (refer to [ATS4](#), default <LF>) can cause problems

## 11.3 AT+CMGD Delete short message

The write command deletes a short message from the preferred message storage `<mem1>` location `<index>`.

### Syntax

Test Command	
AT+CMGD=?	
Response(s)	
OK	
Write Command	
AT+CMGD=<index>	
Response(s)	
OK	
ERROR	
+CMS ERROR	
Reference(s)	
GSM 07.05	
	PIN ASC0 MUX1 MUX2 MUX3 Charge  Last
	● ● ● ● ● ○ ○ ○

### Notes

- If there is no short message stored at the selected index, the response is OK too.
- Users should be aware that when using this AT command quickly after SIM PIN authentication the SIM data may not yet be accessible, resulting in a short delay before the requested AT command response is returned. See Section 18.1, [Restricted access to SIM data after SIM PIN authentication](#) for further detail.

## 11.4 AT+CMGF Select SMS message format

### Syntax

<p>Test Command</p> <p>AT+CMGF=?</p> <p>Response(s)</p> <p>+CMGF: (list of supported &lt;mode&gt;s)</p> <p>OK</p>																	
<p>Read Command</p> <p>AT+CMGF?</p> <p>Response(s)</p> <p>+CMGF: &lt;mode&gt;</p> <p>OK</p>																	
<p>Write Command</p> <p>AT+CMGF=&lt;mode&gt;</p> <p>Response(s)</p> <p>OK</p>																	
<p>Reference(s)</p> <p>GSM 07.05</p>	<table border="1"> <tr> <td>PIN</td> <td>ASC0</td> <td>MUX1</td> <td>MUX2</td> <td>MUX3</td> <td>Charge</td> <td></td> <td>Last</td> </tr> <tr> <td><input type="radio"/></td> <td><input checked="" type="radio"/></td> <td><input checked="" type="radio"/></td> <td><input checked="" type="radio"/></td> <td><input checked="" type="radio"/></td> <td><input type="radio"/></td> <td><input type="radio"/></td> <td><input type="radio"/></td> </tr> </table>	PIN	ASC0	MUX1	MUX2	MUX3	Charge		Last	<input type="radio"/>	<input checked="" type="radio"/>	<input checked="" type="radio"/>	<input checked="" type="radio"/>	<input checked="" type="radio"/>	<input type="radio"/>	<input type="radio"/>	<input type="radio"/>
PIN	ASC0	MUX1	MUX2	MUX3	Charge		Last										
<input type="radio"/>	<input checked="" type="radio"/>	<input checked="" type="radio"/>	<input checked="" type="radio"/>	<input checked="" type="radio"/>	<input type="radio"/>	<input type="radio"/>	<input type="radio"/>										

### Command Description

The write command specifies the input and output format of the short messages.

### Parameter Description

<mode> <sup>(num)(&amp;W)(&amp;V)</sup>	
[0] <sup>(&amp;F)</sup>	PDU mode
1	Text mode

## 11.5 AT+CMGL List SMS messages from preferred store

The write command returns messages with status value `<stat>` from message storage `<mem1>` to the TE. If the status of the message is 'received unread', the status in the storage changes to 'received read'. The execute command is the same as the write command with the given default for `<stat>`.

### Syntax

<p>Test Command</p> <p>AT+CMGL=?</p> <p>Response(s)</p> <p>+CMGL: (list of supported <code>&lt;stat&gt;</code>s)</p> <p>OK</p>																	
<p>Exec Command</p> <p>AT+CMGL</p> <p>Response(s)</p> <p>+CMGL: (see write command for default of <code>&lt;stat&gt;</code>)</p> <p>OK</p>																	
<p>Write Command</p> <p>AT+CMGL=<code>&lt;stat&gt;</code></p> <p>Response(s)</p> <p>Output if text mode (<code>AT+CMGF=1</code>) and command successful: For SMS- SUBMITs and/or SMS-DELIVERs</p> <p>+CMGL: <code>&lt;index&gt;</code>, <code>&lt;stat&gt;</code>, <code>&lt;oa&gt;/&lt;da&gt;</code>, [<code>&lt;alpha&gt;</code>], [<code>&lt;scts&gt;</code>][, <code>&lt;toa&gt;/&lt;toda&gt;</code>, <code>&lt;length&gt;</code>] <code>&lt;data&gt;</code> [... ] OK</p> <p>For SMS-STATUS-REPORTs</p> <p>+CMGL: <code>&lt;index&gt;</code>, <code>&lt;stat&gt;</code>, <code>&lt;fo&gt;</code>, <code>&lt;mr&gt;</code>, [<code>&lt;ra&gt;</code>], [<code>&lt;tora&gt;</code>], <code>&lt;scts&gt;</code>, <code>&lt;dt&gt;</code>, <code>&lt;st&gt;</code> [... ] OK</p> <p>For SMS-Commands</p> <p>+CMGL: <code>&lt;index&gt;</code>, <code>&lt;stat&gt;</code>, <code>&lt;fo&gt;</code>, <code>&lt;ct&gt;</code> [... ] OK</p> <p>Output if PDU mode <code>AT+CMGF=0</code> and command successful: For SMS-SUBMITs and/or SMS-DELIVERs</p> <p>+CMGL: <code>&lt;index&gt;</code>, <code>&lt;stat&gt;</code>, [<code>&lt;alpha&gt;</code>], <code>&lt;length&gt;</code> <code>&lt;pdu&gt;</code> [... ] OK</p> <p>If error is related to ME functionality</p> <p>ERROR +CMS ERROR</p>																	
<p>Reference(s)</p> <p>GSM 07.05</p>	<table border="1"> <thead> <tr> <th>PIN</th> <th>ASC0</th> <th>MUX1</th> <th>MUX2</th> <th>MUX3</th> <th>Charge</th> <th></th> <th>Last</th> </tr> </thead> <tbody> <tr> <td>●</td> <td>●</td> <td>●</td> <td>●</td> <td>●</td> <td>○</td> <td>○</td> <td>○</td> </tr> </tbody> </table>	PIN	ASC0	MUX1	MUX2	MUX3	Charge		Last	●	●	●	●	●	○	○	○
PIN	ASC0	MUX1	MUX2	MUX3	Charge		Last										
●	●	●	●	●	○	○	○										

---

### Notes

- The selected `<mem1>` can contain different types of SMS (e.g. SMS-DELIVERs, SMS-SUBMITs, SMS-STATUS-REPORTs and SMS-COMMANDs), the response may be a mix of the responses of different SM types. TE application can recognize the response format by examining the third response parameter.
- The parameters `<ra>` and `<tor>` will only be displayed if parameter `<ra>` of the `AT+SSCONF` command is set to 1.
- Filler "FF" will not be displayed in PDU status reports if parameter `<ff>` of the `AT+SSCONF` command is set to 1.
- Users should be aware that when using this AT command quickly after SIM PIN authentication the SIM data may not yet be accessible, resulting in a short delay before the requested AT command response is returned. See Section 18.1, [Restricted access to SIM data after SIM PIN authentication](#) for further detail.

## 11.6 AT+CMGR Read SMS messages

The write command returns SMS message with location value `<index>` from message storage `<mem1>` to the TE. If status of the message is 'received unread', status in the storage changes to 'received read'.

### Syntax

<p>Test Command</p> <p>AT+CMGR=?</p> <p>Response(s)</p> <p>OK</p>																			
<p>Write Command</p> <p>AT+CMGR=&lt;index&gt;</p> <p>Response(s)</p> <p>Output if text mode (<code>AT+CMGF=1</code>) and command successful:</p> <p>For SMS-DELIVER</p> <p>+CMGR: &lt;stat&gt;, &lt;oa&gt;, [&lt;alpha&gt;], &lt;scts&gt;[, &lt;toa&gt;, &lt;fo&gt;, &lt;pid&gt;, &lt;dcs&gt;, &lt;sca&gt;, &lt;tosca&gt;, &lt;length&gt;]</p> <p>&lt;data&gt;</p> <p>[...]</p> <p>OK</p> <p>For SMS-SUBMIT</p> <p>+CMGR: &lt;stat&gt;, &lt;da&gt;, [&lt;alpha&gt;][, &lt;toda&gt;, &lt;fo&gt;, &lt;pid&gt;, &lt;dcs&gt;, [&lt;vp&gt;], &lt;sca&gt;, &lt;tosca&gt;, &lt;length&gt;]</p> <p>&lt;data&gt;</p> <p>[...]</p> <p>OK</p> <p>For SMS-STATUS-REPORT</p> <p>+CMGR: &lt;stat&gt;, &lt;fo&gt;, &lt;mr&gt;, [&lt;ra&gt;], [&lt;tora&gt;], &lt;scts&gt;, &lt;dt&gt;, &lt;st&gt;</p> <p>&lt;data&gt;</p> <p>[...]</p> <p>OK</p> <p>For SMS-Commands</p> <p>+CMGR: &lt;stat&gt;, &lt;fo&gt;, &lt;ct&gt;[, &lt;pid&gt;, [&lt;mn&gt;], [&lt;da&gt;], [&lt;toda&gt;], &lt;length&gt;]</p> <p>&lt;data&gt;</p> <p>[...]</p> <p>OK</p> <p>Output if PDU mode (<code>AT+CMGF=0</code>) and command successful:</p> <p>For SMS-SUBMITs and/or SMS-DELIVERs</p> <p>+CMGR: &lt;stat&gt;, [&lt;alpha&gt;], &lt;length&gt;</p> <p>&lt;pdu&gt;</p> <p>[...]</p> <p>OK</p> <p>ERROR</p> <p>+CMS ERROR</p>	<table border="1"> <tr> <td>Reference(s)</td> <td>PIN</td> <td>ASC0</td> <td>MUX1</td> <td>MUX2</td> <td>MUX3</td> <td>Charge</td> <td></td> <td>Last</td> </tr> <tr> <td>GSM 07.05</td> <td>●</td> <td>●</td> <td>●</td> <td>●</td> <td>●</td> <td>○</td> <td>○</td> <td>○</td> </tr> </table>	Reference(s)	PIN	ASC0	MUX1	MUX2	MUX3	Charge		Last	GSM 07.05	●	●	●	●	●	○	○	○
Reference(s)	PIN	ASC0	MUX1	MUX2	MUX3	Charge		Last											
GSM 07.05	●	●	●	●	●	○	○	○											

---

**Notes**

- Response if [AT+CMGR](#) is used to read an empty record index: +CMGR: 0,,0
- Response if [AT+CMGR](#) is used to read a non-existent record index: +CMS ERROR: invalid memory index
- The parameters [<ra>](#) and [<tora>](#) will only be displayed if parameter [<ra>](#) of the [AT^SSCONF](#) command is set to 1.
- Filler "FF" will not be displayed in PDU status reports if parameter [<ff>](#) of the [AT^SSCONF](#) command is set to 1.
- Users should be aware that when using this AT command quickly after SIM PIN authentication the SIM data may not yet be accessible, resulting in a short delay before the requested AT command response is returned. See Section [18.1, Restricted access to SIM data after SIM PIN authentication](#) for further detail.

## 11.7 AT+CMGS Send Short Message

The write command transmits a short message from TE to network (SMS-SUBMIT). After invoking the write command wait for the prompt ">" and then start to write the message. To send the message simply enter <CTRL-Z>. After the prompt a timer will be started to observe the input. To abort sending use <ESC>. Abortion is acknowledged with "OK", though the message will not be sent. The message reference <mr> is returned to the TE on successful message delivery. The value can be used to identify the message in a delivery status report provided as an unsolicited result code.

### Syntax

<p>Test Command</p> <p>AT+CMGS=?</p> <p>Response(s)</p> <p>OK</p>																	
<p>Write Command</p> <p>If text mode (see AT+CMGF=1)</p> <p>AT+CMGS=&lt;da&gt;[, &lt;toda&gt;]&lt;CR&gt; Text can be entered. &lt;CTRL-Z&gt;/&lt;ESC&gt;</p> <p>Response(s)</p> <p>+CMGS: &lt;mr&gt;[, &lt;scts&gt;]</p> <p>OK</p> <p>If sending fails see notes below.</p>																	
<p>Write Command</p> <p>If PDU mode (see AT+CMGF=0)</p> <p>AT+CMGS=&lt;length&gt;&lt;CR&gt; PDU can be entered. &lt;CTRL-Z&gt;/&lt;ESC&gt;</p> <p>Response(s)</p> <p>+CMGS: &lt;mr&gt;[, &lt;ackpdu&gt;]</p> <p>OK</p> <p>If sending fails see notes below.</p>																	
<p>Reference(s)</p> <p>GSM 07.05</p>	<table border="1"> <thead> <tr> <th>PIN</th> <th>ASC0</th> <th>MUX1</th> <th>MUX2</th> <th>MUX3</th> <th>Charge</th> <th></th> <th>Last</th> </tr> </thead> <tbody> <tr> <td>●</td> <td>●</td> <td>●</td> <td>●</td> <td>●</td> <td>○</td> <td>○</td> <td>○</td> </tr> </tbody> </table>	PIN	ASC0	MUX1	MUX2	MUX3	Charge		Last	●	●	●	●	●	○	○	○
PIN	ASC0	MUX1	MUX2	MUX3	Charge		Last										
●	●	●	●	●	○	○	○										

### Notes

- If sending fails, for example, if a message is too long, the result code depends on the current setting of the AT^SM20 command:  
If the AT^SM20 <CmgwMode> equals 1 (factory default) any failure to send a message is responded with "OK". Users should be aware, that despite the "OK" response, the message will not be sent to the subscriber.  
If the AT^SM20 <CmgwMode> equals 0 any failure to send a message is responded with "ERROR".
- If sending fails due to timeout, then  
AT^SM20 <CmgwMode>=1 causes "+CMS ERROR: Unknown error" to be returned;  
AT^SM20 <CmgwMode>=0 causes "+CMS ERROR: timer expired" to be returned.
- Note that some providers do not recognize an @ symbol used in a short message. A widely used alternative is typing "\*" as defined in GSM 03.40 (GPP TS 23.40).
- All characters entered behind the prompt ">" will be recognized as GSM characters. For example, "Back-space" (ASCII character 8) does not delete a character, but will be inserted into the short message as an additional physical character. As a result, the character you wanted to delete still appears in the text, plus the GSM code equivalent of the Backspace key.



- **Message Length in Text Mode**  
The maximum length of a short message depends on the used coding scheme: It is 160 characters if the 7 bit GSM coding scheme is used, and 140 characters according to the 8 bit GSM coding scheme. In case UCS2 character set selected it is highly recommended to set Data Coding Scheme (`<dc>` of `AT+CSMP`) to 16-bit data, otherwise the length of sms user data is restricted to 88 octets. Even better for messages with UCS2 character set is the PDU Mode.
- At baudrates lower than 19200 it is recommended to use the line termination character only (refer to `<n>` of `ATS3`, default `<CR>`) before entering text or PDU. Use of the line termination character followed by the response formatting character (see `<n>` of `ATS4`, default `<LF>`) can cause problems.

## 11.8 AT+CMGW Write Short Messages to Memory

The execute and write commands transmit a short message (either SMS-DELIVER or SMS-SUBMIT) from TE to memory storage `<mem2>`. Memory location `<index>` of the stored message is returned. Message status will be set to 'stored unsent' unless otherwise given in parameter `<stat>`.

After invoking the execute or write command wait for the prompt ">" and then start to write the message. To save the message simply enter `<CTRL-Z>`. After the prompt a timer will be started to observe the input. To abort writing use `<ESC>`. Abortion is acknowledged with "OK", though the message will not be saved.

### Syntax

<p>Test Command</p> <pre>AT+CMGW=?</pre> <p>Response(s)</p> <pre>OK</pre>																	
<p>Exec Command</p> <p>If text mode (see <a href="#">AT+CMGF=1</a>):</p> <pre>AT+CMGW</pre> <p>Response(s)</p> <pre>&lt;CR&gt; Text can be entered. &lt;CTRL-Z&gt;/&lt;ESC&gt; +CMGW: &lt;index&gt; OK</pre> <p>If writing fails</p> <pre>ERROR +CMS ERROR</pre>																	
<p>Write Command</p> <p>If text mode (see <a href="#">AT+CMGF=1</a>):</p> <pre>AT+CMGW=&lt;oa&gt;/&lt;da&gt;[, [&lt;tooa&gt;/&lt;toda&gt;][, &lt;stat&gt;]]&lt;CR&gt; Text can be entered. &lt;CTRL-Z&gt;/&lt;ESC&gt;</pre> <p>Response(s)</p> <pre>+CMGW: &lt;index&gt; OK</pre> <p>If writing fails see notes below.</p>																	
<p>Write Command</p> <p>If PDU mode (see <a href="#">AT+CMGF=0</a>):</p> <pre>AT+CMGW=&lt;length&gt;[, &lt;stat&gt;]&lt;CR&gt; PDU can be entered. &lt;CTRL-Z&gt;/&lt;ESC&gt;</pre> <p>Response(s)</p> <pre>+CMGW: &lt;index&gt; OK</pre> <p>If writing fails see notes below.</p>																	
<p>Reference(s)</p> <pre>GSM 07.05</pre>	<table border="1"> <thead> <tr> <th>PIN</th> <th>ASC0</th> <th>MUX1</th> <th>MUX2</th> <th>MUX3</th> <th>Charge</th> <th></th> <th>Last</th> </tr> </thead> <tbody> <tr> <td>●</td> <td>●</td> <td>●</td> <td>●</td> <td>●</td> <td>○</td> <td>○</td> <td>○</td> </tr> </tbody> </table>	PIN	ASC0	MUX1	MUX2	MUX3	Charge		Last	●	●	●	●	●	○	○	○
PIN	ASC0	MUX1	MUX2	MUX3	Charge		Last										
●	●	●	●	●	○	○	○										

### Notes

- If writing fails, for example, if a message is too long, the result code depends on the current setting of the [AT^SM20](#) command:
  - If the [AT^SM20 <CmgwMode>=1](#) (factory default) any failure to send a message is responded with "OK". Users should be aware, that despite the "OK" response, the message will not be written to the selected SMS storage.
  - If the [AT^SM20 <CmgwMode>](#) equals 0 any failure to write a message is responded with "ERROR".

- If writing fails due to timeout, then  
`AT^SM20 <CmgwMode>=1` causes "+CMS ERROR: Unknown error" to be returned;  
`AT^SM20 <CmgwMode>=0` causes "+CMS ERROR: timer expired" to be returned.
- Note that some providers do not recognize an @ symbol used in a short message. A widely used alternative is typing "\*" as defined in GSM 03.40 (GPP TS 23.40).
- For baudrates lower than 19200 it is recommended to use the line termination character only (refer to `ATS3=<n>`, default `<CR>`) before entering the text or PDU. Use of the line termination character followed by the response formatting character (see `ATS4=<n>`, default `<LF>`) may cause problems.
- SMS-COMMANDS and SMS-STATUS-REPORTs cannot be stored in text mode.
- All characters entered behind the ">" prompt will be recognized as GSM characters. For example, "Back-space" (ASCII character 8) does not delete a character, but will be inserted into the short message as an additional physical character. As a result, the character you wanted to delete still appears in the text, plus the GSM code equivalent of the Backspace key.
- Message Length in Text Mode  
The maximum length of a short message depends on the used coding scheme: It is 160 characters if the 7 bit GSM coding scheme is used, and 140 characters according to the 8 bit GSM coding scheme.  
In case UCS2 character set selected it is highly recommended to set Data Coding Scheme (`<dcs>` of `AT+CSMP`) to 16-bit data, otherwise the length of sms user data is restricted to 88 octets. Even better for messages with UCS2 character set is the PDU Mode.
- The length of 8-bit data coded short messages has to be greater than 0.

## 11.9 AT+CMSS Send short messages from storage

The write command sends message with location value `<index>` from message storage `<mem2>` to the network (SMS-SUBMIT or SMS-COMMAND). If new recipient address `<da>` is given for SMS-SUBMIT, it shall be used instead of the one stored with the message. Reference value `<mr>` is returned to the TE on successful message delivery. Value can be used to identify message upon unsolicited delivery status report result code. If the optional parameter `<da>` is given, the old status of the short message at `<index>` remains unchanged (see `<stat>`).

### Syntax

<p>Test Command</p> <p>AT+CMSS=?</p> <p>Response(s)</p> <p>OK</p>																	
<p>Write Command</p> <p>If text mode (<code>AT+CMGF=1</code>):</p> <p>AT+CMSS=<code>&lt;index&gt;</code>[, <code>&lt;da&gt;</code> [, <code>&lt;toda&gt;</code>]]</p> <p>Response(s)</p> <p>+CMSS: <code>&lt;mr&gt;</code>[, <code>&lt;scts&gt;</code>]</p> <p>OK</p> <p>If sending fails</p> <p>ERROR</p> <p>+CMS ERROR</p>																	
<p>Write Command</p> <p>If PDU mode (<code>AT+CMGF=0</code>):</p> <p>AT+CMSS=<code>&lt;index&gt;</code>[, <code>&lt;da&gt;</code> [, <code>&lt;toda&gt;</code>]]</p> <p>Response(s)</p> <p>+CMSS: <code>&lt;mr&gt;</code>[, <code>&lt;ackpdu&gt;</code>]</p> <p>OK</p> <p>If sending fails</p> <p>ERROR</p> <p>+CMS ERROR</p>																	
<p>Reference(s)</p> <p>GSM 07.05</p>	<table border="1"> <thead> <tr> <th>PIN</th> <th>ASC0</th> <th>MUX1</th> <th>MUX2</th> <th>MUX3</th> <th>Charge</th> <th></th> <th>Last</th> </tr> </thead> <tbody> <tr> <td>●</td> <td>●</td> <td>●</td> <td>●</td> <td>●</td> <td>○</td> <td>○</td> <td>○</td> </tr> </tbody> </table>	PIN	ASC0	MUX1	MUX2	MUX3	Charge		Last	●	●	●	●	●	○	○	○
PIN	ASC0	MUX1	MUX2	MUX3	Charge		Last										
●	●	●	●	●	○	○	○										

## 11.10 AT+CNMA New Message Acknowledgement to ME/TE, only phase 2+

The write / execute command confirms successful receipt of a new message (SMS-DELIVER or SMS-STATUS-REPORT) routed directly to the TE. TA shall not send another +CMT or +CDS result code to TE until previous one is acknowledged. If ME does not receive acknowledgement within required time (network time-out), ME sends RP-ERROR to the network. TA shall automatically disable routing to TE by setting both <mt> and <ds> values of AT+CNMI to zero.

### Syntax

<p>Test Command</p> <p>AT+CNMA=?</p> <p>Response(s)</p> <p>+CNMA: (list of supported &lt;n&gt;s)</p> <p>OK</p>	
<p>Exec Command</p> <p>AT+CNMA</p> <p>Response(s)</p> <p>OK</p> <p>ERROR</p> <p>+CMS ERROR</p>	
<p>Write Command</p> <p>AT+CNMA=&lt;n&gt;</p> <p>Response(s)</p> <p>OK</p> <p>ERROR</p> <p>+CMS ERROR</p>	
<p>Reference(s)</p> <p>GSM 07.05</p>	

### Parameter Description



<n> <sup>(num)</sup>	
0	Parameter is only required for PDU mode. Command operates similarly as in text mode

### Notes

- The execute / write command shall only be used when AT+CSMS parameter <service> equals 1 (= phase 2+).
- Both the execute and the write command can be used no matter whether text mode or PDU mode is activated.
- If multiplex mode is activated (AT+CMUX=0) the AT+CNMI parameter will be set to zero on all channels, if one channel fails to acknowledge an incoming message within the required time.

## 11.11 AT+CNMI New SMS message indications

### Syntax

<p>Test Command</p> <p>AT+CNMI=?</p> <p>Response(s)</p> <p>+CNMI: (list of supported&lt;mode&gt;s), (list of supported&lt;mt&gt;s), (list of supported&lt;bm&gt;s), (list of supported&lt;ds&gt;s), (list of supported&lt;bfr&gt;s)</p> <p>OK</p>																	
<p>Read Command</p> <p>AT+CNMI?</p> <p>Response(s)</p> <p>+CNMI: &lt;mode&gt;, &lt;mt&gt;, &lt;bm&gt;, &lt;ds&gt;, &lt;bfr&gt;</p> <p>OK</p>																	
<p>Write Command</p> <p>AT+CNMI=[&lt;mode&gt;][, &lt;mt&gt;][, &lt;bm&gt;][, &lt;ds&gt;][, &lt;bfr&gt;]</p> <p>Response(s)</p> <p>OK</p> <p>ERROR</p> <p>+CMS ERROR</p>																	
<p>Reference(s)</p> <p>GSM 07.05</p>	<table border="1"> <thead> <tr> <th>PIN</th> <th>ASC0</th> <th>MUX1</th> <th>MUX2</th> <th>MUX3</th> <th>Charge</th> <th></th> <th>Last</th> </tr> </thead> <tbody> <tr> <td>●</td> <td>●</td> <td>●</td> <td>●</td> <td>●</td> <td>○</td> <td>○</td> <td>○</td> </tr> </tbody> </table>	PIN	ASC0	MUX1	MUX2	MUX3	Charge		Last	●	●	●	●	●	○	○	○
PIN	ASC0	MUX1	MUX2	MUX3	Charge		Last										
●	●	●	●	●	○	○	○										

### Unsolicited Result Codes

#### URC 1

<mt>=1:  
+CMTI: <mem3>, <index>  
Indicates that new message has been received

#### URC 2

<mt>=2 (PDU mode enabled):  
+CMT: <length><CR><LF><pdu>  
Indicates that new message has been received

#### URC 3

<mt>=2 (text mode enabled):  
+CMT: <oa>, <scts>[, <toa>, <fo>, <pid>, <dcs>, <sca>, <tosca>, <length>]<CR><LF><data>  
Indicates that new message has been received

#### URC 4

<bm>=2 (PDU mode enabled):  
+CBM: <length><CR><LF><pdu>  
Indicates that new cell broadcast message has been received

URC 5

`<bm>=2` (text mode enabled):  
`+CBM: <sn>, <mid>, <dcs>, <page>, <pages><CR><LF><data>`  
 Indicates that new cell broadcast message has been received

URC 6

`<ds>=1` (PDU mode enabled):  
`+CDS: <length><CR><LF><pdu>`  
 Indicates that new SMS status report has been received

URC 7

`<ds>=1` (text mode enabled):  
`+CDS: <fo>, <mr>[, <ra>][, <tora>], <scts>, <dt>, <st>`  
 Indicates that new SMS status report has been received

URC 8

`<ds>=2:`  
`+CDSI: <mem3>, <index>`  
 Indicates that new SMS status report has been received

### Command Description

The write command selects the procedure how the receipt of new SMS messages from the network is indicated to the TE when TE is active, e.g. DTR signal is ON. If TE is inactive (e.g. DTR signal is OFF), message receiving should be done as specified in GSM 03.38. If the DTR signal is not available or the state of the signal is ignored (V.25ter command [AT&D0](#)), reliable message transfer can be ensured by using [AT+CNMA](#) acknowledgment procedure.

### Parameter Description

<code>&lt;mode&gt;</code> <sup>(num)&amp;(W)&amp;(V)</sup>	
<code>[0]</code> <sup>(&amp;F)</sup>	Buffer unsolicited result codes in the TA. If TA result code buffer is full, indications can be buffered in some other place or the oldest indications may be discarded and replaced with the new received indications.
1	Discard indication and reject new received message unsolicited result codes when TA-TE link is reserved (e.g. in on-line data mode). Otherwise forward them directly to the TE.
2	Buffer unsolicited result codes in the TA when TA-TE link is reserved (e.g. in on-line data mode) and flush them to the TE after reservation. Otherwise forward them directly to the TE.
3	Forward unsolicited result codes directly to the TE. TA-TE link specific inband technique used to embed result codes and data when TA is in on-line data mode.

<code>&lt;mt&gt;</code> <sup>(num)&amp;(W)&amp;(V)</sup>	
Rules for storing received SMS depend on the relevant data coding method (refer to GSM 03.38), preferred memory storage ( <a href="#">AT+CPMS</a> ) setting and this value. Note: If AT command interface is acting as the only display device, the ME must support storage of class 0 messages and messages in the message waiting indication group (discard message)	
<code>[0]</code> <sup>(&amp;F)</sup>	No SMS-DELIVER indications are routed to the TE.
1	If SMS-DELIVER is stored in ME/TA, indication of the memory location is routed to the TE using unsolicited result code.

- |   |   |
|---|---|
| 2 | SMS-DELIVERs, except class 2 messages and messages in the message waiting indication group (store message) are routed directly to the TE using unsolicited result code.   |
| 3 | Class 3 SMS-DELIVERs are routed directly to the TE using unsolicited result codes defined in <code>&lt;mt&gt;=2</code> . Messages of other data coding schemes result in indication as defined in <code>&lt;mt&gt;=1</code> . |

`<bm>`<sup>(num)(&W)(&V)</sup>

Rules for storing received CBMs depend on the relevant data coding method (refer to GSM 03.38), the setting of Select CBM Types (`AT+CSCB`) and this value:

- |                                      |  |
|--------------------------------------|--|
| <code>[0]</code> <sup>(&amp;F)</sup> | No CBM indications are routed to the TE.   |
| 2                                    | New CBMs are routed directly to the TE using unsolicited result code.  |
| 3                                    | Class 3 CBMs are routed directly to TE using unsolicited result codes defined in <code>&lt;bm&gt;=2</code> . |

`<ds>`<sup>(num)(&W)(&V)</sup>

- |                                      |  |
|--------------------------------------|--|
| <code>[0]</code> <sup>(&amp;F)</sup> | No SMS-STATUS-REPORTs are routed to the TE.  |
| 1                                    | SMS-STATUS-REPORTs are routed to the TE using unsolicited result code.   |
| 2                                    | If SMS-STATUS-REPORT is routed in to ME/TA, indication of the memory location is routed to the TE using unsolicited result code. |

`<bfr>`<sup>(num)(&W)(&V)</sup>

- |                                      |   |
|--------------------------------------|---|
| <code>[1]</code> <sup>(&amp;F)</sup> | TA buffer of unsolicited result codes defined within this command is cleared when <code>&lt;mode&gt; 1...3</code> is entered. |
|--------------------------------------|---|

`<index>`<sup>(num)</sup>

Integer type; value in the range of location numbers supported by the associated memory

## Notes



- Each time an SMS or Cell Broadcast Message is received, the Ring Line goes Logic "1" for one second.
- Requirements specific to Multiplex mode:  
In multiplex mode (`AT+CMUX=0`) only one channel can use a phase 2+ parameter. The parameter for `<mt>` and `<ds>` on the other channels have to be set to zero. If either a SM or a Status Report is not acknowledged, all `AT+CNMI` parameter in all channels will be set to zero.
- Handling of Class 0 short messages:  
If the host application is provided with a display and `AT^SSDA=1` has been set Class 0 short messages can be displayed immediately.  
If the host application does not include a display, ME handles Class 0 short messages as though there was no message class, i.e. it will ignore bits 0 and 1 in the `<dcs>` and normal rules for exceeded memory capacity shall apply. This approach is compliant with GSM 03.38 .
- The parameters `<ra>` and `<tora>` will only be displayed if `<ra>` of the `AT^SSCONF` command is set to 1.
- Filler "FF" will not be displayed in PDU status reports if the parameter `<ff>` of `AT^SSCONF` command is set to 1.
- If either a SM or a Status Report is not acknowledged, all `AT+CNMI` parameters in all channels will be set to zero.
- If the ME operates on different instances (MUX channels 1, 2, 3) avoid different settings for routing and indicating SMS. For example, if messages shall be routed directly to one instance of the TE (set with `AT+CNMI`, `AT^SSDA`), it is not possible to activate the presentation of URCs with `AT+CMER` or `AT+CNMI` on another instance. Any attempt to activate settings that conflict with existing settings on another interface, will result in CME ERROR, or accordingly CMS ERROR.



## 11.12 AT+CPMS Preferred SMS message storage

The write command selects memory storages `<mem1>`, `<mem2>`, `<mem3>` to be used for reading, writing, etc.

### Syntax

<p>Test Command</p> <pre>AT+CPMS=?</pre> <p>Response(s)</p> <pre>+CPMS: (list of supported &lt;mem1&gt;s), (list of supported &lt;mem2&gt;s), (list of supported &lt;mem3&gt;s) OK</pre>																	
<p>Read Command</p> <pre>AT+CPMS?</pre> <p>Response(s)</p> <pre>+CPMS: &lt;mem1&gt;, &lt;used1&gt;, &lt;total1&gt;, &lt;mem2&gt;, &lt;used2&gt;, &lt;total2&gt;, &lt;mem3&gt;, &lt;used3&gt;, &lt;total3&gt; OK ERROR +CMS ERROR</pre>																	
<p>Write Command</p> <pre>AT+CPMS=&lt;mem1&gt;[, &lt;mem2&gt;[, &lt;mem3&gt;]]</pre> <p>Response(s)</p> <pre>+CPMS: &lt;used1&gt;, &lt;total1&gt;, &lt;used2&gt;, &lt;total2&gt;, &lt;used3&gt;, &lt;total3&gt; OK ERROR ERROR +CMS ERROR</pre>																	
<p>Reference(s)</p> <p>GSM 07.05</p>	<table border="1"> <thead> <tr> <th>PIN</th> <th>ASC0</th> <th>MUX1</th> <th>MUX2</th> <th>MUX3</th> <th>Charge</th> <th></th> <th>Last</th> </tr> </thead> <tbody> <tr> <td><input checked="" type="radio"/></td> <td><input checked="" type="radio"/></td> <td><input checked="" type="radio"/></td> <td><input checked="" type="radio"/></td> <td><input checked="" type="radio"/></td> <td><input type="radio"/></td> <td><input type="radio"/></td> <td><input type="radio"/></td> </tr> </tbody> </table>	PIN	ASC0	MUX1	MUX2	MUX3	Charge		Last	<input checked="" type="radio"/>	<input checked="" type="radio"/>	<input checked="" type="radio"/>	<input checked="" type="radio"/>	<input checked="" type="radio"/>	<input type="radio"/>	<input type="radio"/>	<input type="radio"/>
PIN	ASC0	MUX1	MUX2	MUX3	Charge		Last										
<input checked="" type="radio"/>	<input checked="" type="radio"/>	<input checked="" type="radio"/>	<input checked="" type="radio"/>	<input checked="" type="radio"/>	<input type="radio"/>	<input type="radio"/>	<input type="radio"/>										

### Parameter Description

`<used1>`<sup>(num)</sup>

Number of messages currently in `<mem1>`

`<used2>`<sup>(num)</sup>

Number of messages currently in `<mem2>`

`<used3>`<sup>(num)</sup>

Number of messages currently in `<mem3>`

`<total1>`<sup>(num)</sup>

Number of messages storable in `<mem1>`

`<total2>`<sup>(num)</sup>

Number of messages storable in `<mem2>`

`<total3>`<sup>(num)</sup>

Number of messages storable in `<mem3>`

## Notes

- The Mobile Equipment storage "ME" offers space for 25 short messages, see [<mem1>](#).
- "MT" is the sum of "ME" (= 25 locations) and "SM" (capacity varies with SIM card). The indices [<index>](#) of the "MT" storage are dependent on the order selected with [AT^SSMSS](#)
- The [<mem1>](#), [<mem2>](#) and [<mem3>](#) parameter will be stored in non-volatile memory.
- The user should be aware that the setting "MT" involves "ME" and "SM", with "ME" being filled up first. If the "ME" storage is full, TC35i will proceed with the "SM" storage.  
Incoming Class 1 short messages (ME specific) will be preferably stored to "ME" and may be transferred to the "SM" storage if "ME" is used up.  
Incoming Class 2 messages (SIM specific) will be stored to the SIM card only, no matter whether or not there is free "ME" space. As a result, the ^SMGO: 2 indication (see [AT^SMGO](#)) may be presented without prior indication of ^SMGO: 1. For more information regarding SIM and ME specific message classes refer to [<dcs>](#) and the following specifications: GSM 03.38 and 3GPP TS23038.
- When [<mem3>](#) is switched over from "MT" to "SM" all free "ME" locations will be filled with dummy short messages. This procedure can take up to 35 seconds, until all the 25 records are written.  
If switching from "MT" to "SM" was not finished due to error or user break, the value of [<mem3>](#) remains "MT", but some of the dummy records remain in the "ME" storage. These records have to be deleted manually.  
When [<mem3>](#) equals "SM", do not delete the dummy messages in the "ME" storage. They will be automatically deleted when you switch back from "SM" to "MT". Again, this may take up to 35 seconds.  
If switching from "SM" to "MT" was not finished due to an error or user break, the value of [<mem3>](#) remains "SM", but the "ME" storage will no longer be filled with dummy records. New incoming short messages may now be written to the "ME" storage, if "SM" is already full. To avoid this, repeat the [AT+CPMS](#) command as soon as possible to switch [<mem3>](#) back to "MT". As an alternative, you can manually delete the dummy records and issue [AT+CPMS=MT,MT,MT](#).
- Multiplexer: In Multiplex mode or when the two physical serial interfaces are connected, the parameter [<mem3>](#) will be the same on all instances, but the settings of [<mem1>](#) and [<mem2>](#) may vary on each channel / interface. As a result, changes on parameter [<mem1>](#) and/or [<mem2>](#) before activating the multiplexer or differences values for other instances can result in not desired behaviours like different outputs for [AT+CMGL](#) and so on.
- While [<mem3>](#) equals "SM" and [<mem1>](#) equals "ME" it is possible that, after deleting short messages from "ME", the freed space on "ME" is reclaimed for new incoming short messages, when there is no space left on the "SM" storage. As it is often the clients concern to have received short messages stored only to the SIM card, inconsistent settings should be generally avoided. This can be achieved simply by using the same parameter for all memory indices.
- Users should be aware that when using this AT command quickly after SIM PIN authentication the SIM data may not yet be accessible, resulting in a short delay before the requested AT command response is returned. See Section 18.1, [Restricted access to SIM data after SIM PIN authentication](#) for further detail.
- The indices [<index>](#) of the storage are dependent on the order selected with [AT^SSMSS](#).

## 11.13 AT+CSCA SMS Service Center Address

Write command updates the SMSC address, through which mobile originated SMS are transmitted. In text mode, setting is used by send and write commands. In PDU mode, setting is used by the same commands, but only when the length of the SMSC address coded into the `<pdu>` parameter equals zero.

### Syntax

Test Command																	
AT+CSCA=?																	
Response(s)																	
OK																	
Read Command																	
AT+CSCA?																	
Response(s)																	
+CSCA: <sca>, <tosca>																	
OK																	
Write Command																	
AT+CSCA=<sca>[, <tosca>]																	
Response(s)																	
OK																	
Reference(s)																	
GSM 07.05																	
	<table border="1"><thead><tr><th>PIN</th><th>ASC0</th><th>MUX1</th><th>MUX2</th><th>MUX3</th><th>Charge</th><th>🔔</th><th>Last</th></tr></thead><tbody><tr><td>●</td><td>●</td><td>●</td><td>●</td><td>●</td><td>○</td><td>○</td><td>○</td></tr></tbody></table>	PIN	ASC0	MUX1	MUX2	MUX3	Charge	🔔	Last	●	●	●	●	●	○	○	○
PIN	ASC0	MUX1	MUX2	MUX3	Charge	🔔	Last										
●	●	●	●	●	○	○	○										

### Notes

- In case of using no parameter after AT+CSCA= the content of `<sca>` will be deleted.
- This command writes the service center address to non-volatile memo.
- The SMS service center address should be entered as specified by the service provider.

## 11.14 AT+CSCB Select Cell Broadcast Message Indication

The test command returns the supported modes as a compound value.  
The write command selects which types of CBMs are to be received by the ME.

### Syntax

<p>Test Command</p> <pre>AT+CSCB=?</pre> <p>Response(s)</p> <pre>+CSCB: (list of supported &lt;mode&gt;s) OK</pre>																	
<p>Read Command</p> <pre>AT+CSCB?</pre> <p>Response(s)</p> <pre>+CSCB: &lt;mode&gt;, &lt;mids&gt;, &lt;dcss&gt; OK</pre>																	
<p>Write Command</p> <pre>AT+CSCB=[&lt;mode&gt;[, &lt;mids&gt;[, &lt;dcss&gt;]]]</pre> <p>Response(s)</p> <pre>OK</pre>																	
<p>Reference(s)</p> <pre>GSM 07.05</pre>	<table border="1"> <thead> <tr> <th>PIN</th> <th>ASC0</th> <th>MUX1</th> <th>MUX2</th> <th>MUX3</th> <th>Charge</th> <th></th> <th>Last</th> </tr> </thead> <tbody> <tr> <td><input checked="" type="radio"/></td> <td><input checked="" type="radio"/></td> <td><input checked="" type="radio"/></td> <td><input checked="" type="radio"/></td> <td><input checked="" type="radio"/></td> <td><input type="radio"/></td> <td><input type="radio"/></td> <td><input type="radio"/></td> </tr> </tbody> </table>	PIN	ASC0	MUX1	MUX2	MUX3	Charge		Last	<input checked="" type="radio"/>	<input checked="" type="radio"/>	<input checked="" type="radio"/>	<input checked="" type="radio"/>	<input checked="" type="radio"/>	<input type="radio"/>	<input type="radio"/>	<input type="radio"/>
PIN	ASC0	MUX1	MUX2	MUX3	Charge		Last										
<input checked="" type="radio"/>	<input checked="" type="radio"/>	<input checked="" type="radio"/>	<input checked="" type="radio"/>	<input checked="" type="radio"/>	<input type="radio"/>	<input type="radio"/>	<input type="radio"/>										

### Parameter Description

<b>&lt;mode&gt;</b> <sup>(num)&amp;(W)</sup>	
Message mode	
[0]	Accept messages that are defined in <b>&lt;mids&gt;</b> and <b>&lt;dcss&gt;</b>
1	Forbid messages that are defined in <b>&lt;mids&gt;</b> and <b>&lt;dcss&gt;</b>
<b>&lt;mids&gt;</b> <sup>(str)</sup>	
Cell Broadcast Message ID specification	
<ul style="list-style-type: none"> <li>For <b>&lt;mode&gt;</b>=0: Six different possible combinations of CBM IDs (e.g. "0,1,5,320-478,922,2000-3000"), default is empty string. In certain configurations, e.g. if using SIMs that contain data in Elementary File EF-CBMID (Cell Broadcast Message Identifier for Data download) less than six combinations may be available. To access a SIM's Elementary File data refer to command <a href="#">AT+CRSM</a>.</li> <li>For <b>&lt;mode&gt;</b>=1: One CBM ID or range of IDs (e.g. "320-478"), default is empty string.</li> </ul>	
<b>&lt;dcss&gt;</b> <sup>(str)</sup>	
CBM data coding scheme specification	
All different possible combinations of CBM data coding schemes (e.g. "0-3,5"). Using default empty string leads to get all CBMs independent of their dcsc.	
A given <b>&lt;dcss&gt;</b> replaces any former value and is used for consecutive requests.	

## 11.15 AT+CSDH Show SMS text mode parameters

The write command sets whether or not detailed header information is shown in text mode result codes.

### Syntax

<p>Test Command</p> <p>AT+CSDH=?</p> <p>Response(s)</p> <p>+CSDH: ((list of supported &lt;show&gt;s)</p> <p>OK</p>																	
<p>Read Command</p> <p>AT+CSDH?</p> <p>Response(s)</p> <p>+CSDH: &lt;show&gt;</p> <p>OK</p>																	
<p>Write Command</p> <p>AT+CSDH=&lt;show&gt;</p> <p>Response(s)</p> <p>+CSDH: &lt;show&gt;</p> <p>OK</p>																	
<p>Reference(s)</p> <p>GSM 07.05</p>	<table border="1"> <thead> <tr> <th>PIN</th> <th>ASC0</th> <th>MUX1</th> <th>MUX2</th> <th>MUX3</th> <th>Charge</th> <th></th> <th>Last</th> </tr> </thead> <tbody> <tr> <td>●</td> <td>●</td> <td>●</td> <td>●</td> <td>●</td> <td>○</td> <td>○</td> <td>○</td> </tr> </tbody> </table>	PIN	ASC0	MUX1	MUX2	MUX3	Charge		Last	●	●	●	●	●	○	○	○
PIN	ASC0	MUX1	MUX2	MUX3	Charge		Last										
●	●	●	●	●	○	○	○										

### Parameter Description

<show> <sup>(num)(&amp;W)</sup>	
[0] <sup>(&amp;F)</sup>	Do not show header values defined in commands <a href="#">AT+CSCA</a> and <a href="#">AT+CSMP</a> (<sca>, <tosca>, <fo>, <vp>, <pid> and <dcs>) nor <length>, <toda> or <tooa> in "+CMTI", <a href="#">AT+CMGL</a> , <a href="#">AT+CMGR</a> result codes for SMS-DELIVERs and SMS-SUBMITs in text mode; for SMS-COMMANDs in +CMGR result code, do not show <pid>, <mn>, <da>, <toda>, <length> or <cdata>
1	Show the values in result codes

## 11.16 AT+CSMP Set SMS text Mode Parameters

The write command selects values for additional parameters needed when the short message is sent to the network or placed in a storage when text format message mode is selected.

It is possible to set the validity period starting from the time when the short message is received by the SMSC (<vp> is in range 0... 255) or define the absolute time of the validity period termination (<vp> is a string). The format of <vp> is given by <fo>. If TA supports the enhanced validity period format, see GSM 03.40), it shall be given as a hexadecimal coded string (e.g. <pdu>) with quotes.

### Syntax

<p>Test Command</p> <pre>AT+CSMP=?</pre> <p>Response(s)</p> <pre>OK</pre>																	
<p>Read Command</p> <pre>AT+CSMP?</pre> <p>Response(s)</p> <pre>+CSMP: &lt;fo&gt;, &lt;vp&gt;/ &lt;scts&gt;, &lt;pid&gt;, &lt;dcS&gt;</pre> <pre>OK</pre>																	
<p>Write Command</p> <pre>AT+CSMP=&lt;fo&gt;[, &lt;vp&gt;/&lt;scts&gt;[, &lt;pid&gt;[, &lt;dcS&gt;]]]</pre> <p>Response(s)</p> <pre>+CSMP: &lt;index&gt;</pre> <pre>OK</pre> <p>If sending fails</p> <pre>ERROR</pre> <pre>+CMS ERROR</pre>																	
<p>Reference(s)</p> <pre>GSM 07.05</pre>	<table border="1"> <thead> <tr> <th>PIN</th> <th>ASC0</th> <th>MUX1</th> <th>MUX2</th> <th>MUX3</th> <th>Charge</th> <th></th> <th>Last</th> </tr> </thead> <tbody> <tr> <td><input checked="" type="radio"/></td> <td><input checked="" type="radio"/></td> <td><input checked="" type="radio"/></td> <td><input checked="" type="radio"/></td> <td><input checked="" type="radio"/></td> <td><input type="radio"/></td> <td><input type="radio"/></td> <td><input type="radio"/></td> </tr> </tbody> </table>	PIN	ASC0	MUX1	MUX2	MUX3	Charge		Last	<input checked="" type="radio"/>	<input checked="" type="radio"/>	<input checked="" type="radio"/>	<input checked="" type="radio"/>	<input checked="" type="radio"/>	<input type="radio"/>	<input type="radio"/>	<input type="radio"/>
PIN	ASC0	MUX1	MUX2	MUX3	Charge		Last										
<input checked="" type="radio"/>	<input checked="" type="radio"/>	<input checked="" type="radio"/>	<input checked="" type="radio"/>	<input checked="" type="radio"/>	<input type="radio"/>	<input type="radio"/>	<input type="radio"/>										

### Parameter Description

<fo><sup>(num)</sup>

First Octet

depending on the command or result code: first octet of GSM 03.40 SMS-DELIVER, SMS-SUBMIT (default 17), SMS-STATUS-REPORT, or SMS-COMMAND (default 2) in integer format

0...17<sup>(&F)</sup>...255

<vp><sup>(num)</sup>

Depending on SMS-SUBMIT <fo> setting: GSM 03.40 TP-Validity-Period either in integer format or in time-string format (refer <dt>)

0...167<sup>(&F)</sup>...255

<dcS><sup>(num)</sup>

Data Coding Scheme

GSM 03.38 SMS Data Coding Scheme, or Cell Broadcast Data Coding Scheme in integer format

0<sup>(&F)</sup>...247

---

<pid><sup>(num)</sup>

Protocol Identifier

GSM 03.40 TP-Protocol-Identifier in integer format

0(&F)...255

**Notes**

- When storing a SMS DELIVER from the TE to the preferred memory storage in text mode (using the [AT+CMGW](#) write command), <vp> field can be used for <scts>.
- The command writes the parameters to the non-volatile memory.

## 11.17 AT+CSMS Select Message Service

### Syntax

<p>Test Command</p> <p>AT+CSMS=?</p> <p>Response(s)</p> <p>+CSMS: (list of supported&lt;service&gt;s)</p> <p>OK</p>																	
<p>Read Command</p> <p>AT+CSMS?</p> <p>Response(s)</p> <p>+CSMS: &lt;service&gt;, &lt;mt&gt;, &lt;mo&gt;, &lt;bm&gt;</p> <p>OK</p>																	
<p>Write Command</p> <p>AT+CSMS=&lt;service&gt;</p> <p>Response(s)</p> <p>+CSMS: &lt;mt&gt;, &lt;mo&gt;, &lt;bm&gt;</p> <p>OK</p> <p>ERROR</p> <p>+CMS ERROR</p>																	
<p>Reference(s)</p> <p>GSM 07.05</p>	<table border="1"> <thead> <tr> <th>PIN</th> <th>ASC0</th> <th>MUX1</th> <th>MUX2</th> <th>MUX3</th> <th>Charge</th> <th></th> <th>Last</th> </tr> </thead> <tbody> <tr> <td><input checked="" type="radio"/></td> <td><input checked="" type="radio"/></td> <td><input checked="" type="radio"/></td> <td><input checked="" type="radio"/></td> <td><input checked="" type="radio"/></td> <td><input type="radio"/></td> <td><input type="radio"/></td> <td><input type="radio"/></td> </tr> </tbody> </table>	PIN	ASC0	MUX1	MUX2	MUX3	Charge		Last	<input checked="" type="radio"/>	<input checked="" type="radio"/>	<input checked="" type="radio"/>	<input checked="" type="radio"/>	<input checked="" type="radio"/>	<input type="radio"/>	<input type="radio"/>	<input type="radio"/>
PIN	ASC0	MUX1	MUX2	MUX3	Charge		Last										
<input checked="" type="radio"/>	<input checked="" type="radio"/>	<input checked="" type="radio"/>	<input checked="" type="radio"/>	<input checked="" type="radio"/>	<input type="radio"/>	<input type="radio"/>	<input type="radio"/>										

### Parameter Description

<b>&lt;service&gt;</b> <sup>(num)(&amp;W)(&amp;V)</sup>	
0(&F)	GSM 03.40 and GSM 03.41 (the syntax of SMS AT commands is compatible with GSM 07.05 Phase 2 version 4.7.0; Phase 2+ features which do not require new command syntax may be supported, e.g. correct routing of messages with new Phase 2+ data coding schemes)
1	GSM 03.40 and GSM 03.41 (the syntax of SMS AT commands is compatible with GSM 07.05 Phase 2+ version; the requirement of <service> setting 1 is mentioned under corresponding command descriptions).

<b>&lt;mt&gt;</b> <sup>(num)</sup>	
Mobile Terminated Messages:	
0	Type not supported
1	Type supported

<b>&lt;mo&gt;</b> <sup>(num)</sup>	
Mobile Originated Messages:	
0	Type not supported
1	Type supported



---

<bm><sup>(num)</sup>

Broadcast Type Messages:

0	Type not supported
1	Type supported

**Note**

- If CSMS is switched to <service>= 1, all messages with phase 2+ (see [AT+CNMI](#) with mt= 2, mt= 3, ds= 1) have to be acknowledged with [AT+CNMA](#).

## 11.18 AT^SCML List Concatenated Short Messages from preferred store

The write command returns messages with status value `<stat>` from message storage `<mem1>` to the TE. If the status of the message is 'received unread', the status in the storage changes to 'received read'. The execute command is the same as the write command with the given default for `<stat>`. See notes of [AT+CMGL](#).

### Syntax

#### Test Command

AT^SCML=?

Response(s)

^SCML: (list of supported `<stat>`s)  
OK

#### Exec Command

AT^SCML

Response(s)

^SCML: (see write command for default of `<stat>`)  
OK

#### Write Command

AT^SCML=`<stat>`

Response(s)

Output if text mode (`AT+CMGF=1`) and command successful:

For SMS-SUBMITs and/or SMS-DELIVERs

^SCML: `<index>`, `<stat>`, `<oa>/<da>`, [`<alpha>`], [`<scts>`]][, `<toa>/<toda>`, `<length>`]][, `<seq>`,  
`<max>`, `<ieia>`, `<ref>`]  
`<data>`  
[... ]  
OK

For SMS-STATUS-REPORTs

^SCML: `<index>`, `<stat>`, `<fo>`, `<mr>`, [`<ra>`], [`<tora>`], `<scts>`, `<dt>`, `<st>`  
[... ]  
OK

For SMS-Commands

^SCML: `<index>`, `<stat>`, `<fo>`, `<ct>`  
[... ]  
OK

Output if PDU mode (`AT+CMGF=0`) and command successful:

For SMS- SUBMITs and/or SMS-DELIVERs

^SCML: `<index>`, `<stat>`, [`<alpha>`], `<length>`  
`<pdu>`  
[... ]  
OK

If error is related to ME functionality

ERROR  
+CMS ERROR

#### Reference(s)

--

PIN	ASC0	MUX1	MUX2	MUX3	Charge		Last
●	●	●	●	●	○	○	○

## 11.19 AT^SCMR Read Concatenated Short Messages

The write command returns the message with location value `<index>` from message storage `<mem1>` to the TE. If the status of the message is 'received unread', the status in the storage changes to 'received read'. See notes of [AT+CMGR](#).

### Syntax

<p>Test Command</p> <p>AT^SCMR=?</p> <p>Response(s)</p> <p>OK</p>	<p>Write Command</p> <p>AT^SCMR=&lt;index&gt;</p> <p>Response(s)</p> <p>Output if text mode (<a href="#">AT+CMGF=1</a>) and command successful:</p> <p>For SMS-DELIVER</p> <p>^SCMR: &lt;stat&gt;, &lt;oa&gt;, [<a href="#">&lt;alpha&gt;</a>], &lt;scts&gt;[, &lt;toa&gt;, &lt;fo&gt;, &lt;pid&gt;, &lt;dcs&gt;, &lt;sca&gt;, &lt;tosca&gt;, &lt;length&gt;][, &lt;seq&gt;, &lt;max&gt;, &lt;ieia&gt;, &lt;ref&gt;]</p> <p>&lt;data&gt;</p> <p>[...]</p> <p>OK</p> <p>For SMS-SUBMIT</p> <p>^SCMR: &lt;stat&gt;, &lt;da&gt;, [<a href="#">&lt;alpha&gt;</a>][, &lt;toda&gt;, &lt;fo&gt;, &lt;pid&gt;, &lt;dcs&gt;, [<a href="#">&lt;vp&gt;</a>], &lt;sca&gt;, &lt;tosca&gt;, &lt;length&gt;][, &lt;seq&gt;, &lt;max&gt;, &lt;ieia&gt;, &lt;ref&gt;]</p> <p>&lt;data&gt;</p> <p>[...]</p> <p>OK</p> <p>For SMS-STATUS-REPORT</p> <p>^SCMR: &lt;stat&gt;, &lt;fo&gt;, &lt;mr&gt;, [<a href="#">&lt;ra&gt;</a>], [<a href="#">&lt;tora&gt;</a>], &lt;scts&gt;, &lt;dt&gt;, &lt;st&gt;</p> <p>&lt;data&gt;</p> <p>[...]</p> <p>OK</p> <p>For SMS-Commands</p> <p>^SCMR: &lt;stat&gt;, &lt;fo&gt;, &lt;ct&gt;[, &lt;pid&gt;, [<a href="#">&lt;mn&gt;</a>], [<a href="#">&lt;da&gt;</a>], [<a href="#">&lt;toda&gt;</a>], &lt;length&gt;]</p> <p>&lt;data&gt;</p> <p>[...]</p> <p>OK</p> <p>Output if PDU mode (<a href="#">AT+CMGF=0</a>) and command successful:</p> <p>For SMS-SUBMITs and/or SMS-DELIVERs</p> <p>^SCMR: &lt;stat&gt;, [<a href="#">&lt;alpha&gt;</a>], &lt;length&gt;</p> <p>&lt;pdu&gt;</p> <p>[...]</p> <p>OK</p> <p>ERROR</p> <p>+CMS ERROR</p>																
<p>Reference(s)</p> <p>--</p>	<table border="1"> <tr> <td>PIN</td> <td>ASC0</td> <td>MUX1</td> <td>MUX2</td> <td>MUX3</td> <td>Charge</td> <td></td> <td>Last</td> </tr> <tr> <td>●</td> <td>●</td> <td>●</td> <td>●</td> <td>●</td> <td>○</td> <td>○</td> <td>○</td> </tr> </table>	PIN	ASC0	MUX1	MUX2	MUX3	Charge		Last	●	●	●	●	●	○	○	○
PIN	ASC0	MUX1	MUX2	MUX3	Charge		Last										
●	●	●	●	●	○	○	○										

## 11.20 AT^SCMS Send Concatenated Short Messages

Sending a concatenated message is similar to sending a "normal" message, except that each segment of the concatenated message must be identified by the additional parameters `<seq>`, `<ieia>` and `<ref>`. To send all segments of the message one by one, the `AT^SCMS` write command must be executed for each segment.

The write command transmits one segment of a concatenated short message from TE to network (SMS-SUBMIT).

After invoking the write command wait for the prompt `>` and then start to write the message. To send the message simply enter `<CTRL-Z>`. After the prompt a timer will be started to observe the input.

To abort sending use `<ESC>`. Abortion is acknowledged with "OK", though the message will not be sent.

The message reference `<mr>` is returned to the TE on successful message delivery. The value can be used to identify the message in a delivery status report provided as an unsolicited result code.

### Syntax

<p>Test Command</p> <pre>AT^SCMS=?</pre> <p>Response(s)</p> <pre>OK</pre>	<p>Write Command</p> <p>Command syntax for text mode (see <code>AT+CMGF=1</code>):</p> <pre>AT^SCMS=&lt;da&gt;[, &lt;toda&gt;], &lt;seq&gt;, &lt;max&gt;, &lt;ieia&gt;, &lt;ref&gt;&lt;CR&gt; Text can be entered &lt;CTRL-Z&gt;/&lt;ESC&gt;</pre> <p>Response(s)</p> <pre>+CMGS: &lt;mr&gt;[, &lt;scts&gt;]</pre> <p>OK</p> <p>If sending fails</p> <pre>ERROR</pre> <pre>+CMS ERROR</pre>																
<p>Reference(s)</p> <pre>--</pre>	<table border="1"> <thead> <tr> <th>PIN</th> <th>ASC0</th> <th>MUX1</th> <th>MUX2</th> <th>MUX3</th> <th>Charge</th> <th></th> <th>Last</th> </tr> </thead> <tbody> <tr> <td>●</td> <td>●</td> <td>●</td> <td>●</td> <td>●</td> <td>○</td> <td>○</td> <td>○</td> </tr> </tbody> </table>	PIN	ASC0	MUX1	MUX2	MUX3	Charge		Last	●	●	●	●	●	○	○	○
PIN	ASC0	MUX1	MUX2	MUX3	Charge		Last										
●	●	●	●	●	○	○	○										

### Notes

- See notes provided for `AT+CMGS`.
- Command is only available if `AT+CMGF=1`.

## 11.21 AT^SCMW Write Concatenated Short Messages to Memory

Writing a concatenated message to the memory is similar to writing a "normal" message, except that each segment of the concatenated message must be identified by the additional parameters `<seq>`, `<ieia>` and `<ref>`. To store all segments of the message one by one, the `AT^SCMW` write command must be executed for each segment.

The write commands transmits one segment of a concatenated SMS (either SMS-DELIVER or SMS-SUBMIT) from TE to memory storage `<mem2>`. Memory location `<index>` of the stored message is returned. Message status will be set to 'stored unsent' unless otherwise given in parameter `<stat>`.

### Syntax

<p>Test Command</p> <pre>AT^SCMW=?</pre> <p>Response(s)</p> <pre>OK</pre>	<p>Write Command</p> <p>If text mode (see <code>AT+CMGF=1</code>)</p> <pre>AT^SCMW=&lt;oa&gt;/&lt;da&gt;, [&lt;tooa&gt;/&lt;toda&gt;][, &lt;stat&gt;], &lt;seq&gt;, &lt;max&gt;, &lt;ieia&gt;, &lt;ref&gt;&lt;CR&gt; Text can be entered. &lt;CTRL-Z&gt;/&lt;ESC&gt;</pre> <p>Response(s)</p> <pre>^SCMW: &lt;index&gt; OK If writing fails ERROR +CMS ERROR</pre>																
<p>Reference(s)</p> <pre>--</pre>	<table border="1"> <thead> <tr> <th>PIN</th> <th>ASC0</th> <th>MUX1</th> <th>MUX2</th> <th>MUX3</th> <th>Charge</th> <th></th> <th>Last</th> </tr> </thead> <tbody> <tr> <td>●</td> <td>●</td> <td>●</td> <td>●</td> <td>●</td> <td>○</td> <td>○</td> <td>○</td> </tr> </tbody> </table>	PIN	ASC0	MUX1	MUX2	MUX3	Charge		Last	●	●	●	●	●	○	○	○
PIN	ASC0	MUX1	MUX2	MUX3	Charge		Last										
●	●	●	●	●	○	○	○										

### Notes

- Command is only available if `AT+CMGF=1`.
- To send or delete a concatenated short message please use the known SMS commands, see `AT+CMSS` for sending and `AT+CMGD` for deleting.
- See notes provided for `AT+CMGW`.

## 11.22 AT^SLMS List SMS Memory Storage

[AT^SLMS](#) indicates the max. capacity of each SMS storage type and the number of locations currently used.

### Syntax

Test Command	AT^SLMS=?																
Response(s)	OK																
Exec Command	AT^SLMS																
Response(s)	<pre> ^SLMS: "MT",&lt;total3&gt;, &lt;used3&gt; ^SLMS: "SM",&lt;total1&gt;, &lt;used1&gt; ^SLMS: "ME",&lt;total2&gt;, &lt;used2&gt; OK ERROR +CMS ERROR                     </pre>																
Reference(s)	<table border="1"> <tr> <td>PIN</td> <td>ASC0</td> <td>MUX1</td> <td>MUX2</td> <td>MUX3</td> <td>Charge</td> <td></td> <td>Last</td> </tr> <tr> <td>●</td> <td>●</td> <td>●</td> <td>●</td> <td>●</td> <td>○</td> <td>○</td> <td>○</td> </tr> </table>	PIN	ASC0	MUX1	MUX2	MUX3	Charge		Last	●	●	●	●	●	○	○	○
PIN	ASC0	MUX1	MUX2	MUX3	Charge		Last										
●	●	●	●	●	○	○	○										

### Parameter Description

**<total1><sup>(num)</sup>**

Maximum number of messages storable in the SMS memory of the SIM (physical storage "SM")

**<total2><sup>(num)</sup>**

Maximum number of messages storable in the SMS memory of the Mobile Equipment (physical storage "ME")

**<total3><sup>(num)</sup>**

Sum of "SM" and "ME", indicated as "MT". Maximum number of all messages storable in the SIM memory and the Mobile Equipment memory.

**<used1><sup>(num)</sup>**

Number of messages currently stored in the SMS memory of the SIM (physical storage "SM")

**<used2><sup>(num)</sup>**

Number of messages currently stored in the SMS memory of the Mobile Equipment (physical storage "ME")

**<used3><sup>(num)</sup>**

Concatenated logical SMS storages of SIM ("SM") and Mobile Equipment ("ME"). Sum of all messages currently stored, indicated as "MT".

### Note

- Users should be aware that when using this AT command quickly after SIM PIN authentication the SIM data may not yet be accessible, resulting in a short delay before the requested AT command response is returned. See Section 18.1, [Restricted access to SIM data after SIM PIN authentication](#) for further detail.

## 11.23 AT^SMGL List Short Messages from preferred store without setting status to REC READ

The write command allows to select a status type and lists, from the message storage `<mem1>`, all messages that currently have the specified `<stat>`. The major difference over the standard command `AT+CMGL` is that the status of the listed messages remains `unread` (unread remains unread). The execute command is the same as the write command, but uses the given default of `<stat>`.

### Syntax

<p>Test Command</p> <p>AT^SMGL=?</p> <p>Response(s)</p> <p>same as <a href="#">AT+CMGL</a></p>																	
<p>Exec Command</p> <p>AT^SMGL</p> <p>Response(s)</p> <p>^SMGL: (For default values of <code>&lt;stat&gt;</code>, see "Section 11.1, <a href="#">SMS parameters.</a>")</p> <p>OK</p>																	
<p>Write Command</p> <p>AT^SMGL=<code>&lt;stat&gt;</code></p> <p>Response(s)</p> <p>same as <a href="#">AT+CMGL</a></p>																	
<p>Reference(s)</p> <p>--</p>	<table border="1"> <thead> <tr> <th>PIN</th> <th>ASC0</th> <th>MUX1</th> <th>MUX2</th> <th>MUX3</th> <th>Charge</th> <th></th> <th>Last</th> </tr> </thead> <tbody> <tr> <td>●</td> <td>●</td> <td>●</td> <td>●</td> <td>●</td> <td>○</td> <td>○</td> <td>○</td> </tr> </tbody> </table>	PIN	ASC0	MUX1	MUX2	MUX3	Charge		Last	●	●	●	●	●	○	○	○
PIN	ASC0	MUX1	MUX2	MUX3	Charge		Last										
●	●	●	●	●	○	○	○										

### Notes

- The selected `<mem1>` can contain different types of SMs (e.g. SMS-DELIVERs, SMS-SUBMITs, SMS-STATUS-REPORTs and SMS-COMMANDs), the response may be a mix of the responses of different SM types. TE application can recognize the response format by examining the third response parameter.
- Users should be aware that when using this AT command quickly after SIM PIN authentication the SIM data may not yet be accessible, resulting in a short delay before the requested AT command response is returned. See Section 18.1, [Restricted access to SIM data after SIM PIN authentication](#) for further detail.

## 11.24 AT^SMGO Set or query SMS overflow presentation mode or query SMS overflow

The write command sets the overflow presentation mode.  
The read command returns the overflow presentation mode and the SMS overflow status.

### Syntax

<p>Test Command</p> <p>AT^SMGO=?</p> <p>Response(s)</p> <p>^SMGO: (list of supported&lt;n&gt;s)</p> <p>OK</p>																	
<p>Read Command</p> <p>AT^SMGO?</p> <p>Response(s)</p> <p>^SMGO: &lt;n&gt;, &lt;mode&gt;</p> <p>OK</p> <p>ERROR</p> <p>+CMS ERROR</p>																	
<p>Write Command</p> <p>AT^SMGO=&lt;n&gt;</p> <p>Response(s)</p> <p>OK</p> <p>ERROR</p> <p>CME ERROR</p>																	
<p>Reference(s)</p> <p>--</p>	<table border="1"> <thead> <tr> <th>PIN</th> <th>ASC0</th> <th>MUX1</th> <th>MUX2</th> <th>MUX3</th> <th>Charge</th> <th></th> <th>Last</th> </tr> </thead> <tbody> <tr> <td>●</td> <td>●</td> <td>●</td> <td>●</td> <td>●</td> <td>○</td> <td>○</td> <td>○</td> </tr> </tbody> </table>	PIN	ASC0	MUX1	MUX2	MUX3	Charge		Last	●	●	●	●	●	○	○	○
PIN	ASC0	MUX1	MUX2	MUX3	Charge		Last										
●	●	●	●	●	○	○	○										

### Unsolicited Result Code

SMS buffer change:

^SMGO: <mode>

Status of SMS buffer has changed.

### Parameter Description

<b>&lt;n&gt;</b> <sup>(num)(&amp;W)(&amp;V)</sup>	
SMS overflow presentation mode	
[0] <sup>(&amp;F)</sup>	Disable
1	Enable
<b>&lt;mode&gt;</b> <sup>(num)(&amp;V)</sup>	
SMS overflow status	
0	Space available
1	SMS buffer full (The buffer for received short messages is <mem3>. See <a href="#">AT+CPMS</a> .)
2	Buffer full and new message waiting in SC for delivery to phone



---



### Notes

- Incoming short messages with message class 1 (ME specific short messages) or class 2 (SIM specific short messages), see [<dc>](#) in GSM 03.38, will be stored either in "ME" or in "SM" storage. Therefore the "[^SMGO: 2](#)" indication could occur, without issuing the indication "[^SMGO: 1](#)" before. The indication "[^SMGO: 1](#)" means that both buffers ("ME" and "SM") are full.
- For more information regarding SIM and ME specific message classes refer to [<dc>](#) and the following specifications: GSM 03.38 and 3GPP TS 23.038 .

## 11.25 AT^SMGR Read short message without setting status to REC READ

The [AT^SMGR](#) command is a proprietary command which has the same syntax as [AT+CMGR](#). The only functional difference is that the status "REC UNREAD" of a short message is not overwritten to "REC READ".

### Syntax

Test Command																	
AT^SMGR=?																	
Response(s)																	
^SMGR : OK																	
Write Command																	
AT^SMGR=<index>																	
Response(s)																	
see <a href="#">AT+CMGR</a>																	
Reference(s)																	
--	<table border="1"><thead><tr><th>PIN</th><th>ASC0</th><th>MUX1</th><th>MUX2</th><th>MUX3</th><th>Charge</th><th></th><th>Last</th></tr></thead><tbody><tr><td>●</td><td>●</td><td>●</td><td>●</td><td>●</td><td>○</td><td>○</td><td>○</td></tr></tbody></table>	PIN	ASC0	MUX1	MUX2	MUX3	Charge		Last	●	●	●	●	●	○	○	○
PIN	ASC0	MUX1	MUX2	MUX3	Charge		Last										
●	●	●	●	●	○	○	○										

### Note

- Users should be aware that when using this AT command quickly after SIM PIN authentication the SIM data may not yet be accessible, resulting in a short delay before the requested AT command response is returned. See Section [18.1, Restricted access to SIM data after SIM PIN authentication](#) for further detail.

## 11.26 AT^SSCONF SMS Command Configuration

AT^SSCONF controls details of some SMS related commands. Please note that AT^SSCONF settings are stored volatile, i.e. after restart or reset the default values will be restored.

### Syntax

<p>Test Command</p> <pre>AT^SSCONF=?</pre> <p>Response(s)</p> <pre>^SSCONF : list of supported &lt;ra&gt;s , list of supported &lt;ff&gt;s OK</pre>
<p>Read Command</p> <pre>AT^SSCONF?</pre> <p>Response(s)</p> <pre>^SSCONF : &lt;ra&gt;, &lt;ff&gt; OK</pre>
<p>Write Command</p> <pre>AT^SSCONF=&lt;ra&gt;[, &lt;ff&gt;]</pre> <p>Response(s)</p> <pre>OK</pre>

PIN	ASC0	MUX1	MUX2	MUX3	Charge		Last
○	●	●	●	●	○	○	○

### Parameter Description

<b>&lt;ra&gt;<sup>(num)</sup></b>	
Display recipient address	
[0] <sup>(&amp;F)</sup>	TC35i does not display <ra> and <tora>. These parameters are used with the result codes of AT+CMGL, AT^SMGL, AT+CMGR, AT^SMGR and the URC "+CDS".
1	TC35i displays <ra> and <tora>.
<b>&lt;ff&gt;<sup>(num)</sup></b>	
Display filler bits	
[0] <sup>(&amp;F)</sup>	TC35i displays filler bits. <ff> appears in the result codes of AT+CMGL, AT^SMGL, AT+CMGR and AT^SMGR.
1	TC35i does not display filler bits (FF) with status report in PD U mode. This might be useful because filler bits are network dependent.

## 11.27 AT^SSDA Set SMS Display Availability

This command allows to notify the TC35i of its controlling application's capability to immediately display incoming SMS on a display.

If the application is able to display incoming short messages, a class 0 message shall be displayed immediately. However, if it does not, class 0 messages shall be treated as if no message class is determined (GSM 03.38[16]).

The effect of this command if `<da>=1` is to determine the behavior of parameter `<mt>` of `AT+CNMI`:

If `<da>=1` and `<mt>=1` incoming class 0 messages need to be acknowledged with `AT+CNMA` (see also `AT+CNMI` and `AT+CSMS`)

If multiplex mode is enabled (`AT+CMUX`) and `<da>=1` with `<mt>=1` is set on any logical channel, all other channels have to use `<mt>=0`.

### Syntax

<p>Test Command</p> <pre>AT^SSDA=?</pre> <p>Response(s)</p> <pre>^SSDA: list of supported &lt;da&gt;s OK</pre>																	
<p>Read Command</p> <pre>AT^SSDA?</pre> <p>Response(s)</p> <pre>^SSDA: &lt;da&gt; OK</pre>																	
<p>Write Command</p> <pre>AT^SSDA=&lt;da&gt;</pre> <p>Response(s)</p> <pre>OK</pre>																	
<p>Reference(s)</p> <pre>--</pre>	<table border="1"> <thead> <tr> <th>PIN</th> <th>ASC0</th> <th>MUX1</th> <th>MUX2</th> <th>MUX3</th> <th>Charge</th> <th></th> <th>Last</th> </tr> </thead> <tbody> <tr> <td><input type="radio"/></td> <td><input checked="" type="radio"/></td> <td><input checked="" type="radio"/></td> <td><input checked="" type="radio"/></td> <td><input checked="" type="radio"/></td> <td><input type="radio"/></td> <td><input type="radio"/></td> <td><input type="radio"/></td> </tr> </tbody> </table>	PIN	ASC0	MUX1	MUX2	MUX3	Charge		Last	<input type="radio"/>	<input checked="" type="radio"/>	<input checked="" type="radio"/>	<input checked="" type="radio"/>	<input checked="" type="radio"/>	<input type="radio"/>	<input type="radio"/>	<input type="radio"/>
PIN	ASC0	MUX1	MUX2	MUX3	Charge		Last										
<input type="radio"/>	<input checked="" type="radio"/>	<input checked="" type="radio"/>	<input checked="" type="radio"/>	<input checked="" type="radio"/>	<input type="radio"/>	<input type="radio"/>	<input type="radio"/>										

### Parameter Description

<code>&lt;da&gt;</code> <sup>(num)</sup>	Display Availability
0(&F)	Application is not able to display incoming short message
1	Application is able to display incoming short message

### Note

- If the ME operates on different instances (MUX channels 1, 2, 3) avoid different settings for routing and indicating short messages. For example, if messages shall be routed directly to one instance of the TE (set with `AT+CNMI`, `AT^SSDA`), it is not possible to activate the presentation of URCs with `AT+CMER` or `AT+CNMI` on another instance. Any attempt to activate settings that conflict with existing settings on another interface, will result in CME ERROR, or accordingly CMS ERROR.

## 11.28 AT^SSMSS Set Short Message Storage Sequence

The short message storage "MT" (see [AT+CPMS](#)) is a logical storage. It consists of two physical storages "ME" and "SM". This command allows to select the sequence of addressing this storage.

### Syntax

<p>Test Command</p> <p>AT^SSMSS=?</p> <p>Response(s)</p> <p>^SSMSS: (list of supported) &lt;seq&gt;s</p>																	
<p>Read Command</p> <p>AT^SSMSS?</p> <p>Response(s)</p> <p>^SSMSS: &lt;seq&gt;</p> <p>OK</p>																	
<p>Write Command</p> <p>AT^SSMSS=&lt;seq&gt;</p> <p>Response(s)</p> <p>OK</p>																	
<p>Reference(s)</p> <p>--</p>	<table border="1"> <thead> <tr> <th>PIN</th> <th>ASC0</th> <th>MUX1</th> <th>MUX2</th> <th>MUX3</th> <th>Charge</th> <th></th> <th>Last</th> </tr> </thead> <tbody> <tr> <td><input type="radio"/></td> <td><input checked="" type="radio"/></td> <td><input checked="" type="radio"/></td> <td><input checked="" type="radio"/></td> <td><input checked="" type="radio"/></td> <td><input type="radio"/></td> <td><input type="radio"/></td> <td><input type="radio"/></td> </tr> </tbody> </table>	PIN	ASC0	MUX1	MUX2	MUX3	Charge		Last	<input type="radio"/>	<input checked="" type="radio"/>	<input checked="" type="radio"/>	<input checked="" type="radio"/>	<input checked="" type="radio"/>	<input type="radio"/>	<input type="radio"/>	<input type="radio"/>
PIN	ASC0	MUX1	MUX2	MUX3	Charge		Last										
<input type="radio"/>	<input checked="" type="radio"/>	<input checked="" type="radio"/>	<input checked="" type="radio"/>	<input checked="" type="radio"/>	<input type="radio"/>	<input type="radio"/>	<input type="radio"/>										

### Parameter Description

<seq> <sup>(num)</sup>	MT sequence
0(&F)	"MT" storage is "ME" then "SM"
1	"MT" storage is "SM" then "ME"

### Note

- Access to the SIM storage is faster. For compatibility with previous software re-leases, the "MT" sequence <seq>=0 is the factory default.

## 12. SIM related Commands

The AT commands described in this chapter are related to the Subscriber Identity Module (SIM) connected to TC35i.

### Note:

If using data from the SIM please bear in mind that the content of all Elementary Files is *subject to change* at any moment!

This is true because the network can change the SIM's data in the background via the SIM Application Toolkit (SAT) procedure "Data download to SIM". For a detailed description please refer to GSM 11.14, [21].

To get informed that changing Elementary Files has taken place the TA needs to hook to the SAT Proactive Command "REFRESH". To achieve this, the AT command interface of SAT, i.e. Remote-SAT, needs to be activated. An overview is given at Chapter 13., [SIM Application Toolkit \(SAT\) Commands](#), additional information is available with the document "Remote-SAT User Guide" [4].

### 12.1 AT+CRSM Restricted SIM Access

[AT+CRSM](#) offers easy access of the Elementary Files on the SIM. Access to the SIM database is restricted to the commands which are listed at [<command>](#).

All parameters of [AT+CRSM](#) are used as specified by GSM 11.11 [20]. TC35i handles internally all required SIM interface locking and file selection routines.

As response to the command, the TC35i sends the actual SIM information parameters and response data. Error result code "+CME ERROR" may be returned if the command cannot be passed to the SIM, e.g. if the SIM is not inserted. However, failure in the execution of the command in the SIM is reported in [<sw1>](#) and [<sw2>](#) parameters.

[AT+CRSM](#) requires PIN authentication. However, using [<command>](#) "READ BINARY" and [<command>](#) "READ RECORD" is possible before PIN authentication and if the SIM is blocked (state after three failed PIN authentication attempts) to access the contents of the following Elementary Files:

EF Symbol	EF Name	EF ID (hex.)	EF ID (dec.)
EF <sub>ICCID</sub>	ICC identification	2FE2	12258
EF <sub>ELP</sub>	Extended language preference	2F05	12037
EF <sub>LP</sub>	Language preference	6F05	28421
EF <sub>SPN</sub>	Service provider name	6F46	28486
EF <sub>AD</sub>	Administrative data	6FAD	28589
EF <sub>Phase</sub>	Phase identification	6FAE	28590
EF <sub>ECC</sub>	Emergency call codes	6FB7	28599

Please beware of *possible changes to Elementary Files* by the network at any time, refer Chapter 12., [SIM related Commands](#).

### Syntax

Test Command

AT+CRSM=?

Response(s)

OK

Write Command

```
AT+CRSM=<command>[, <fileID>[, <P1>, <P2>, <P3>[, <data>]]]
```

Response(s)

```
+CRSM: <sw1>,<sw2>[,<response>]
OK
ERROR
+CME ERROR: <err>
```

Reference(s)

GSM 07.07

PIN	ASC0	MUX1	MUX2	MUX3	Charge	🔔	Last
🔒	●	●	●	●	○	○	○

**Parameter Description**

**<command><sup>(num)</sup>**

SIM command number.

176	READ BINARY
178	READ RECORD
192	GET RESPONSE
214	UPDATE BINARY
220	UPDATE RECORD
242	STATUS

**<fileID><sup>(num)</sup>**

Identifier for an elementary data file on SIM, if used by [<command>](#).

**<P1><sup>(num)</sup>**

Parameter to be passed on by the TC35i to the SIM.  
 0...255

**<P2><sup>(num)</sup>**

Parameter to be passed on by the TC35i to the SIM.  
 0...255

**<P3><sup>(num)</sup>**

Parameter to be passed on by the TC35i to the SIM.  
 0...255

**<data><sup>(str)</sup>**

Information which shall be written to the SIM (hexadecimal character format).

**<sw1><sup>(num)</sup>**

Status information from the SIM about the execution of the actual command. It is returned in both cases, on successful or failed execution of the command.  
 0...255

---

`<sw2>`<sup>(num)</sup>

Status information from the SIM about the execution of the actual command. It is returned in both cases, on successful or failed execution of the command.

0...255

`<response>`<sup>(str)</sup>

Response data in case of a successful completion of the previously issued command. "STATUS" and "GET RESPONSE" commands return data, which gives information about the currently selected elementary data field. This information includes the type of file and its size.

After "READ BINARY" or "READ RECORD" commands the requested data will be returned.

`<response>` is empty after "UPDATE BINARY" or "UPDATE RECORD" commands.



## 12.2 AT^SCKS Query SIM and Chip Card Holder Status

This command controls the SIM connection presentation mode and queries the connection status of the SIM and the card holder tray of the TC35i.

### Syntax

<p>Test Command</p> <pre>AT^SCKS=?</pre> <p>Response(s)</p> <pre>^SCKS: (list of supported &lt;mode&gt;s) OK</pre>	
<p>Read Command</p> <pre>AT^SCKS?</pre> <p>Response(s)</p> <pre>^SCKS: &lt;mode&gt;, &lt;SimStatus&gt; OK ERROR +CME ERROR: &lt;err&gt;</pre>	
<p>Write Command</p> <pre>AT^SCKS=&lt;mode&gt;</pre> <p>Response(s)</p> <pre>OK ERROR +CME ERROR: &lt;err&gt;</pre>	
<p>Reference(s)</p> <pre>--</pre>	

### Unsolicited Result Code

`^SCKS: <SimStatus>`

During startup, and if the TC35i's SIM connection status has changed an unsolicited result code (URC) is issued.

### Command Description

The read command returns the URC presentation mode and the status of the SIM card connection.

The write command enables or disables the presentation of URCs to report whether or not the SIM card is connected.

If the ME is powered down or reset (`AT+CFUN` or `AT^SMSO`) the current presentation mode setting `<mode>` will not be retained. Therefore the setting `<mode>=1` needs to be restored after power on the TC35i or may be saved in the user profile (`AT&W`).

### Parameter Description

<code>&lt;mode&gt;</code> <sup>(num)(&amp;W)(&amp;V)</sup>	
0(&F)	Suppress unsolicited result codes
1	Output unsolicited result codes
<code>&lt;SimStatus&gt;</code> <sup>(num)(&amp;V)</sup>	
0	Card holder tray removed or SIM connection error
1	SIM inserted(refer to note)

---

**Note**

- [<SimStatus>](#) reflects the status of the SIM and the card holder tray. Therefore if an empty SIM card tray is inserted, two URCs will be presented, indicating the status 1 followed by 0, i.e. a SIM is inserted into the card holder tray but no SIM connection could be established.

**Example**

```
AT^SCKS=1           Activates the presentation of unsolicited result codes
OK
```

Now, after inserting an empty card tray the following URCs appear:

```
^SCKS: 1           Tray connected
^SCKS: 0           No SIM card found
```

## 12.3 AT^SSET Indicate SIM data ready

After power-up and personalization (PIN entry if required) the ME starts reading data from SIM. The `AT^SSET` command controls the presentation of the "`^SSIM READY`" URC which indicates, on the corresponding serial channel, when the ME has finished reading SIM data. Afterwards all commands that depend on SIM data fields can be used, e.g. SMS and phonebook commands. See Section 18.1, [Restricted access to SIM data after SIM PIN authentication](#) for further detail.

### Syntax

<p>Test Command</p> <pre>AT^SSET=?</pre> <p>Response(s)</p> <pre>^SSET: (list of supported &lt;n&gt;s) OK</pre>																	
<p>Read Command</p> <pre>AT^SSET?</pre> <p>Response(s)</p> <pre>^SSET: &lt;n&gt; OK ERROR +CME ERROR: &lt;err&gt;</pre>																	
<p>Write Command</p> <pre>AT^SSET=[&lt;n&gt;]</pre> <p>Response(s)</p> <pre>OK ERROR +CME ERROR: &lt;err&gt;</pre>																	
<p>Reference(s)</p> <pre>--</pre>	<table border="1"> <tr> <td>PIN</td> <td>ASC0</td> <td>MUX1</td> <td>MUX2</td> <td>MUX3</td> <td>Charge</td> <td></td> <td>Last</td> </tr> <tr> <td><input type="radio"/></td> <td><input checked="" type="radio"/></td> <td><input checked="" type="radio"/></td> <td><input checked="" type="radio"/></td> <td><input checked="" type="radio"/></td> <td><input type="radio"/></td> <td><input type="radio"/></td> <td><input type="radio"/></td> </tr> </table>	PIN	ASC0	MUX1	MUX2	MUX3	Charge		Last	<input type="radio"/>	<input checked="" type="radio"/>	<input checked="" type="radio"/>	<input checked="" type="radio"/>	<input checked="" type="radio"/>	<input type="radio"/>	<input type="radio"/>	<input type="radio"/>
PIN	ASC0	MUX1	MUX2	MUX3	Charge		Last										
<input type="radio"/>	<input checked="" type="radio"/>	<input checked="" type="radio"/>	<input checked="" type="radio"/>	<input checked="" type="radio"/>	<input type="radio"/>	<input type="radio"/>	<input type="radio"/>										

### Unsolicited Result Code

`^SSIM READY`

The URC acknowledges to the user that SIM data is accessible. Before that, any attempt to access a phonebook, view SMS or access SIM data will result in "+CME ERROR: 14" (SIM busy).

### Parameter Description

<code>&lt;n&gt;</code> <sup>(num)(&amp;W)(&amp;V)</sup>	
URC presentation mode	
0 <sup>(&amp;F)</sup>	Disable URC " <code>^SSIM READY</code> " indication.
1	Enable URC " <code>^SSIM READY</code> " indication.

## 12.4 AT^SCID Display SIM card identification number

### Syntax

Test Command	AT^SCID=?
Response(s)	OK
Exec Command	AT^SCID
Response(s)	^SCID: <cid> OK ERROR +CME ERROR: <err>
Reference(s)	--

PIN	ASC0	MUX1	MUX2	MUX3	Charge		Last
<input type="radio"/>	<input checked="" type="radio"/>	<input checked="" type="radio"/>	<input checked="" type="radio"/>	<input checked="" type="radio"/>	<input type="radio"/>	<input type="radio"/>	<input type="radio"/>

### Command Description

TA returns the card identification number in SIM (SIM file EF<sub>ICCID</sub>, see GSM 11.11 Chap.10.1.1) as string type.

### Parameter Description

<cid><sup>(str)</sup>  
card identification number of SIM card

## 12.5 AT+CXXCID Display card ID

### Syntax

Test Command							
AT+CXXCID=?							
Response(s)							
OK							
Exec Command							
AT+CXXCID							
Response(s)							
+CXXCID: <cid>							
OK							
ERROR							
+CME ERROR: <err>							
Reference(s)							
--							
PIN	ASC0	MUX1	MUX2	MUX3	Charge		Last
<input type="radio"/>	<input checked="" type="radio"/>	<input checked="" type="radio"/>	<input checked="" type="radio"/>	<input checked="" type="radio"/>	<input type="radio"/>	<input type="radio"/>	<input type="radio"/>

### Command Description

TA returns the card identification number in SIM (SIM file EF ICCID, see GSM 11.11 Chap.10.1.1) as string type.

### Note

- See also: [AT^SCID](#).

## 13. SIM Application Toolkit (SAT) Commands

This chapter offers a brief reference of commands and responses related to the TC35i's SIM Application Toolkit (SAT) implementation. Detailed information is available with the document "Remote-SAT User Guide" [4]. Please contact the Application Engineering Department at Cinterion Wireless Modules GmbH for details.

ETSI specification GSM 11.14 [21] defines SAT in detail.

SAT allows for the execution of applications provided by a Subscriber Identity Module (SIM). Usually SIM cards are used for storing GSM network provider and user specific data, e.g. phonebook entries and Short Messages (SMS). However, a SIM card may also hold a SIM Application.

Since the TC35i has SAT functionality it is able to execute the commands issued by applications implemented on a network provider specific SIM card.

Two groups of commands are used between the ME and the SIM Application:

- Proactive Commands are issued to the TC35i's SAT from the SIM Application, such as "DISPLAY TEXT".
- Envelope Commands are responded to the SIM Application from the TC35i, such as "MENU SELECTION".

### 13.1 AT^SSTA SAT Interface Activation

#### Syntax

Test Command AT^SSTA=? Response(s) ^SSTA: (list of supported <state>s), (list of supported <Alphabet>s) OK																	
Read Command AT^SSTA? Response(s) ^SSTA: <state>, <Alphabet>, <allowedInstance>, <SatProfile> OK																	
Write Command AT^SSTA=<mode>[, <Alphabet>] Response(s) OK																	
Reference(s) --	<table border="1"> <thead> <tr> <th>PIN</th> <th>ASC0</th> <th>MUX1</th> <th>MUX2</th> <th>MUX3</th> <th>Charge</th> <th>🔔</th> <th>Last</th> </tr> </thead> <tbody> <tr> <td>○</td> <td>●</td> <td>●</td> <td>●</td> <td>●</td> <td>○</td> <td>○</td> <td>○</td> </tr> </tbody> </table>	PIN	ASC0	MUX1	MUX2	MUX3	Charge	🔔	Last	○	●	●	●	●	○	○	○
PIN	ASC0	MUX1	MUX2	MUX3	Charge	🔔	Last										
○	●	●	●	●	○	○	○										

#### Command Description

The read command can be used to request the current operating status and the used alphabet of the Remote-SAT interface.

The write command is used to activate the AT command interface of the SIM Application Toolkit in the TC35i and needs to be issued after every power on. However, removing and inserting the SIM does not affect the activation status.

SAT commands which are not using the AT interface (non MMI related SAT commands , e.g. PROVIDE LOCAL INFORMATION) could be executed without activating Remote-SAT.

### Parameter Description

<state><sup>(num)</sup>

TC35i Remote-SAT interface states

0	RESET
1	OFF
2	IDLE
3	PAC
4	WAIT

<Alphabet><sup>(num)</sup>

0	GSM character set Input of a character requests one byte, e.g. "Y".
1	UCS2 To display the 16 bit value of characters represented in UCS2 alphabet a 4 byte string is required, e.g. "0059" is coding the character "Y". For details please refer to ISO/IEC 10646.

<allowedInstance><sup>(num)</sup>

0	SAT is already used on another instance (logical channel in case of the multiplex protocol). Only test and read commands can be used.
1	SAT may be started on this instance via the write version of this command.

<SatProfile><sup>(str)</sup>

SAT profile according to GSM 11.14 [21].  
The profile tells the SIM Application which features (e.g. proactive commands) are supported by the SIM Application Toolkit implementation of the TC35i.

<mode><sup>(num)</sup>

1	Activate Remote-SAT
---	---------------------

### Note

- To limit the time Remote-SAT is kept in states PAC or WAIT any ongoing (but unanswered) Proactive Command is automatically aborted after 10 minutes with Terminal Response "ME currently unable to process command" or "No response from user" if applicable. An URC "Terminate Proactive Command" will be send to the external application in this case, too.

## 13.2 ^SSTN SAT Notification

### Unsolicited Result Codes

#### URC 1

Proactive Command notification

^SSTN: `<cmdType>`

Every time the SIM Application issues a Proactive Command, via the ME, the TA will receive a notification. This indicates the type of Proactive Command issued.

`AT^SSTGI` must then be used by the TA to request the parameters of the Proactive Command from the ME. Upon receiving the `^SSTGI` response from the ME, the TA must send `AT^SSTR` to confirm the execution of the Proactive Command and provide any required user response, e.g. a selected menu item.

#### URC 2

Terminate Proactive Command notification

^SSTN: `<cmdTerminateValue>`

When the SIM application has issued a Proactive Command to the ME, it is possible that this command will be terminated later. URC "`^SSTN`" is sent with a different Proactive Command type number (added terminate offset 100) to indicate the termination of the specified command.

The state changes to idle. Therefore the TA should avoid sending any further commands related to the terminated Proactive Command, e.g. `AT^SSTGI` or `AT^SSTR`.

#### URC 3

Notification that SIM Application has returned to main menu

^SSTN: 254

Notification to the TA when the SIM Application has finished a command cycle and again enters its main menu, which was transferred with an URC "`^SSTN: 37`" (SET UP MENU) at start up.

This URC should be used to open this menu on the screen.

The TA does not need to respond directly, i.e. `AT^SSTR` is not required.

#### URC 4

SIM reset notification

^SSTN: 255

Notification to the TA if a Proactive Command "REFRESH - SIM Reset" has been issued by the SIM Application, please refer to `AT^SSTGI`.

This URC should be used to set the TAs application to its initial state since the SIM Application will start from the beginning, too.

The TA does not need to respond directly, i.e. related `AT^SSTGI` and `AT^SSTR` are neither required nor allowed.

Since the ME is still busy on SIM access the ME may respond with "+CME ERROR: SIM blocked" or "+CME ERROR: SIM busy" on following PIN required AT Commands for a while. Then TA shall retry until the ME responds with "OK". The time needed for this process depends on the SIM and may take more than 10 seconds.

### Parameter Description

`<cmdType>`<sup>(num)</sup>

Proactive Command number

`<cmdTerminateValue>`<sup>(num)</sup>

Defined as `<cmdType>` + terminate offset. The terminate offset equals 100.



## 13.3 AT^SSTGI SAT Get Information

Regularly this command is used upon receipt of an URC "**^SSTN**" to request the parameters of the Proactive Command.

Then the TA is expected to acknowledge the **AT^SSTGI** response with **AT^SSTR** to confirm that the Proactive Command has been executed. **AT^SSTR** will also provide any user information, e.g. a selected menu item. The Proactive Command type value specifies to which "**^SSTN**" the command is related.

### Syntax

<p>Test Command</p> <p>AT^SSTGI=?</p> <p>Response(s)</p> <p>^SSTGI : (list of supported &lt;state&gt;s), (list of supported &lt;cmdType&gt;s)</p> <p>OK</p>																	
<p>Read Command</p> <p>AT^SSTGI?</p> <p>Response(s)</p> <p>^SSTGI : &lt;state&gt;, &lt;cmdType&gt;</p> <p>OK</p>																	
<p>Write Command</p> <p>AT^SSTGI=&lt;cmdType&gt;</p> <p>Response(s)</p> <p>OK</p> <p>ERROR</p> <p>+CME ERROR</p>																	
<p>Reference(s)</p> <p>--</p>	<table border="1"> <tr> <td>PIN</td> <td>ASC0</td> <td>MUX1</td> <td>MUX2</td> <td>MUX3</td> <td>Charge</td> <td></td> <td>Last</td> </tr> <tr> <td><input type="radio"/></td> <td><input checked="" type="radio"/></td> <td><input checked="" type="radio"/></td> <td><input checked="" type="radio"/></td> <td><input checked="" type="radio"/></td> <td><input type="radio"/></td> <td><input type="radio"/></td> <td><input type="radio"/></td> </tr> </table>	PIN	ASC0	MUX1	MUX2	MUX3	Charge		Last	<input type="radio"/>	<input checked="" type="radio"/>	<input checked="" type="radio"/>	<input checked="" type="radio"/>	<input checked="" type="radio"/>	<input type="radio"/>	<input type="radio"/>	<input type="radio"/>
PIN	ASC0	MUX1	MUX2	MUX3	Charge		Last										
<input type="radio"/>	<input checked="" type="radio"/>	<input checked="" type="radio"/>	<input checked="" type="radio"/>	<input checked="" type="radio"/>	<input type="radio"/>	<input type="radio"/>	<input type="radio"/>										

### Parameter Description

<state> <sup>(num)</sup>	
TC35i Remote-SAT interface states	
0	RESET
1	OFF
2	IDLE
3	PAC
4	WAIT

<cmdType><sup>(num)</sup>

Related Proactive Command

## 13.4 AT^SSTR SAT Response

The TA is expected to acknowledge the [AT^SSTGI](#) response with [AT^SSTR](#) to confirm that the Proactive Command has been executed. [AT^SSTR](#) will also provide any user information, e.g. a selected menu item.

### Syntax

<p>Test Command</p> <p>AT^SSTR=?</p> <p>Response(s)</p> <p>^SSTR: (list of supported &lt;state&gt;s), (list of supported &lt;cmdType&gt;s)</p> <p>OK</p>																	
<p>Read Command</p> <p>AT^SSTR?</p> <p>Response(s)</p> <p>^SSTR: &lt;state&gt;, &lt;cmdType&gt;</p> <p>OK</p>																	
<p>Write Command</p> <p>AT^SSTR=&lt;cmdType&gt;, &lt;status&gt;[, &lt;inputNumber&gt;][, &lt;inputString&gt;]</p> <p>Response(s)</p> <p>OK</p>																	
<p>Reference(s)</p> <p>--</p>	<table border="1"> <tr> <td>PIN</td> <td>ASC0</td> <td>MUX1</td> <td>MUX2</td> <td>MUX3</td> <td>Charge</td> <td></td> <td>Last</td> </tr> <tr> <td><input type="radio"/></td> <td><input checked="" type="radio"/></td> <td><input checked="" type="radio"/></td> <td><input checked="" type="radio"/></td> <td><input checked="" type="radio"/></td> <td><input type="radio"/></td> <td><input type="radio"/></td> <td><input type="radio"/></td> </tr> </table>	PIN	ASC0	MUX1	MUX2	MUX3	Charge		Last	<input type="radio"/>	<input checked="" type="radio"/>	<input checked="" type="radio"/>	<input checked="" type="radio"/>	<input checked="" type="radio"/>	<input type="radio"/>	<input type="radio"/>	<input type="radio"/>
PIN	ASC0	MUX1	MUX2	MUX3	Charge		Last										
<input type="radio"/>	<input checked="" type="radio"/>	<input checked="" type="radio"/>	<input checked="" type="radio"/>	<input checked="" type="radio"/>	<input type="radio"/>	<input type="radio"/>	<input type="radio"/>										

### Parameter Description

<p>&lt;state&gt;<sup>(num)</sup></p> <p>TC35i Remote-SAT interface states</p> <table border="1"> <tr> <td>0</td> <td>RESET</td> </tr> <tr> <td>1</td> <td>OFF</td> </tr> <tr> <td>2</td> <td>IDLE</td> </tr> <tr> <td>3</td> <td>PAC</td> </tr> <tr> <td>4</td> <td>WAIT</td> </tr> </table>	0	RESET	1	OFF	2	IDLE	3	PAC	4	WAIT
0	RESET									
1	OFF									
2	IDLE									
3	PAC									
4	WAIT									
<p>&lt;cmdType&gt;<sup>(num)</sup></p> <p>Number related to Proactive Command or event type according to GSM 11.14 [21].</p>										
<p>&lt;status&gt;<sup>(num)</sup></p> <p>Command status return regarding the type of action that has taken place, e.g. action performed by the user. Values are in accordance with GSM 11.14 [21].</p>										
<p>&lt;inputNumber&gt;<sup>(num)</sup></p> <p>Response number entered by user</p>										
<p>&lt;inputString&gt;<sup>(str)</sup></p> <p>Response string entered by user</p>										

## 14. Phonebook Commands

The AT commands described in this chapter allow the external application to access the phonebooks located in the TC35i's memory or on the attached Subscriber Identity Module (SIM).

### 14.1 Sort Order for Phonebooks

Due to the support of UCS2 for the `<text>` part of phonebook entries, the sort order for phonebook records follows the algorithm published as Unicode Technical Standard #10, "Unicode Collation Algorithm".

A memory-optimized version of the proposed collation tables "[AllKeys]" from Unicode Technical Standard #10 is used in order to determine collation weights for Code points between 0000 and 06FF, and composed keys are used for Code points from ranges 0700 to 33FF, A000 to D7FF and E000 to FFFD. Code Points not referenced in these tables will be assigned a default collation weight with their unicode value as level 1 weight. Decomposition is not supported.

Phonebook entries whose names contain only characters from the GSM07.07 default alphabet are converted internally into their UCS2 equivalents in order to achieve consistent sorting results.

For the user, this means that:

- Punctuation marks and other non-alphabetical characters from the common latin-based character sets, and from the standard GSM character set, will be sorted before any alphabetical characters. The ordering in which these marks appear as compared to other non-alphabetical characters from the same group is determined by their collation weights and does not reflect their code values in the UCS2 or GSM alphabet tables above. Please refer to [www.unicode.org](http://www.unicode.org) for detail.
- Alphabetical characters from the common latin-based character sets, and from the standard GSM character set, will be sorted according to their underlying base characters, plus the collation weights of their accent signs.
- Only collation levels 1 and 2 are regarded, so sorting is not case-sensitive.

Example: the european letters "Å" (GSM 0EH, UCS2 00C5h), "æ" (GSM 1DH, UCS2 00E6h), "ç" (GSM 09h, UCS2 00E7h), "a" (GSM 61H, UCS2 0061h) and "b" (GSM 62H, UCS2 0062h) will be sorted in order "a", "Å", "æ" "b", "ç" although their numerical values in GSM and UCS2 suggest a different ordering.

#### Reference(s)

Unicode Technical Standard #10, "Unicode Collation Algorithm"

## 14.2 AT+CPBR Read from Phonebook

AT+CPBR serves to read one or more entries from the phonebook selected with AT command AT+CPBS.

The AT+CPBR test command returns the location range supported by the current phonebook storage, the maximum length of <number> field and the maximum length of <text> field.

Note: Length information may not be available while SIM storage is selected. If storage does not offer format information, the format list contains empty parentheses.

The AT+CPBR write command determines the phonebook entry to be displayed with <location1> or a location range from <location1> to <location2>. Hence, if no <location2> is given only the entry at <location1> will be displayed.

If no entries are found at the selected location "OK" will be returned.

### Syntax

<p>Test Command</p> <pre>AT+CPBR=?</pre> <p>Response(s)</p> <pre>+CPBR: (1-&lt;maxloc&gt;), &lt;nlength&gt;, &lt;tlength&gt;</pre> <p>OK</p> <p>+CME ERROR</p>	<p>Write Command</p> <pre>AT+CPBR=&lt;location1&gt;[, &lt;location2&gt;]</pre> <p>Response(s)</p> <pre>[+CPBR: &lt;location1&gt;, &lt;number&gt;, &lt;type&gt;, &lt;text&gt;]</pre> <pre>[+CPBR: &lt;location2&gt;, &lt;number&gt;, &lt;type&gt;, &lt;text&gt;]</pre> <p>OK</p> <p>+CME ERROR</p>																
<p>Reference(s)</p> <p>GSM 07.07, GSM 11.11</p>	<table border="1"> <tr> <td>PIN</td> <td>ASC0</td> <td>MUX1</td> <td>MUX2</td> <td>MUX3</td> <td>Charge</td> <td></td> <td>Last</td> </tr> <tr> <td><input checked="" type="radio"/></td> <td><input checked="" type="radio"/></td> <td><input checked="" type="radio"/></td> <td><input checked="" type="radio"/></td> <td><input checked="" type="radio"/></td> <td><input type="radio"/></td> <td><input type="radio"/></td> <td><input type="radio"/></td> </tr> </table>	PIN	ASC0	MUX1	MUX2	MUX3	Charge		Last	<input checked="" type="radio"/>	<input checked="" type="radio"/>	<input checked="" type="radio"/>	<input checked="" type="radio"/>	<input checked="" type="radio"/>	<input type="radio"/>	<input type="radio"/>	<input type="radio"/>
PIN	ASC0	MUX1	MUX2	MUX3	Charge		Last										
<input checked="" type="radio"/>	<input checked="" type="radio"/>	<input checked="" type="radio"/>	<input checked="" type="radio"/>	<input checked="" type="radio"/>	<input type="radio"/>	<input type="radio"/>	<input type="radio"/>										

### Parameter Description

<location1><sup>(num)</sup>

The first (lowest) location number within phonebook memory where to start reading. The maximum range supported by the current phonebook is given in the test command response.

If <location1> exceeds the upper bound <maxloc> (as indicated by the test command), command will respond with "+CME ERROR: invalid index".

<location2><sup>(num)</sup>

The last (highest) location number within phonebook memory where to stop reading. The maximum range supported by the current phonebook is given in the test command response.

If both <location1> and <location2> are in the range indicated by the test command parameter <max-loc>, the list of entries will be output and terminated with "OK".

If <location2> exceeds the range indicated by the test command parameter <maxloc>, the list of entries will be output but terminated with "+CME ERROR: invalid index".

<number><sup>(str)</sup>

Phone number in format specified by <type>, it may be an empty string.

`<type>`<sup>(num)</sup>

Type of address octet, which defines the used type of number (ton) and the numbering plan identification (npi). Please consider that for types other than 129 or 145 dialing from phonebook with `ATD<mem><n>` is, depending on the network, not always possible (refer to GSM 04.08 subclause 10.5.4.7 for details). See also `<type>` of `AT+CPBW`.

Possible values are:

145	Dialing string <code>&lt;number&gt;</code> includes international access code character '+'
161	National number. Network support of this type is optional.
209	Dialing string <code>&lt;number&gt;</code> has been saved as ASCII string and includes non-digit characters other than "*", "#" or "+". Note that phonebook entries saved with this type cannot be dialed.
255	Dialing string <code>&lt;number&gt;</code> is a command to control a Supplementary Service, i.e. "*", "#" codes are contained. Network support of this type is optional.
129	Otherwise

`<text>`<sup>(str)(+CSCS)</sup>

Text assigned to a phone number. The maximum length for this parameter is given with test command response parameter `<tlength>`.

If using an ASCII terminal characters which are coded differently in ASCII and GSM have to be entered via escape sequences as described in Section 1.5, [Supported character sets](#).

`<maxloc>`<sup>(num)</sup>

Maximum location number for the currently selected storage. For phonebooks located on the SIM this value depends on the SIM card type.

`<nlength>`<sup>(num)</sup>

Maximum length of phone number for "normal" locations. Depending on the storage a limited number of locations with extended memory is available per phonebook. These locations allow storing numbers with twice the standard length, which is 2\* `<nlength>` digits for normal numbers, but only `<nlength>` digits for numbers saved with `<type>=209`.

`<tlength>`<sup>(num)</sup>

Maximum length of `<text>` assigned to the telephone number. The value indicated by the test command is given in octets. If `<text>` is given as GSM characters each character corresponds to one octet. If the `<text>` string is given in UCS2, the maximum number of characters depends on the coding scheme used for the alpha field of the SIM according to GSM 11.11, Annex B [20]. In the worst case the number of UCS2 characters is at least one less than half the number of GSM characters.

### Note

- Users should be aware that when using this AT command quickly after SIM PIN authentication the SIM data may not yet be accessible, resulting in a short delay before the requested AT command response is returned. See Section 18.1, [Restricted access to SIM data after SIM PIN authentication](#) for further detail.

### Example

```
AT+CPBR=?
```

```
+CPBR:(1-100),20,17
```

```
AT+CPBR=1,3
```

```
+CPBR:1,"+999999",145,"Charlie"
```

```
+CPBR:2,"+777777",145,"Bill"
```

```
+CPBR:3,"+888888",145,"Arthur"
```

First run the [AT+CPBR](#) test command to find out the maximum range of entries stored in the active phonebook.

TC35i returns the supported values, where 100 is the supported range of location numbers, 20 is the length of the phone number and 17 is the maximum length of the associated text.

Then use the [AT+CPBR](#) write command to display the phonebook entries sorted by location numbers.

## 14.3 AT+CPBS Select phonebook memory storage

**AT+CPBS** selects the active phonebook storage, i.e. the phonebook storage that all subsequent phonebook commands will be operating on.

The read command returns the currently selected **<storage>**, the number of **<used>** entries and the **<total>** number of entries available for this storage. The test command returns all supported **<storage>**s as compound value.

### Syntax

<p>Test Command</p> <p>AT+CPBS=?</p> <p>Response(s)</p> <p>+CPBS: (list of supported <b>&lt;storage&gt;</b>s)</p> <p>OK</p> <p>+CME ERROR</p>																	
<p>Read Command</p> <p>AT+CPBS?</p> <p>Response(s)</p> <p>+CPBS: <b>&lt;storage&gt;</b>, <b>&lt;used&gt;</b>, <b>&lt;total&gt;</b></p> <p>OK</p> <p>+CME ERROR</p>																	
<p>Write Command</p> <p>AT+CPBS=<b>&lt;storage&gt;</b></p> <p>Response(s)</p> <p>OK</p> <p>+CME ERROR:</p>																	
<p>Reference(s)</p> <p>GSM07.07</p>	<table border="1"> <tr> <td>PIN</td> <td>ASC0</td> <td>MUX1</td> <td>MUX2</td> <td>MUX3</td> <td>Charge</td> <td></td> <td>Last</td> </tr> <tr> <td><input checked="" type="radio"/></td> <td><input checked="" type="radio"/></td> <td><input checked="" type="radio"/></td> <td><input checked="" type="radio"/></td> <td><input checked="" type="radio"/></td> <td><input type="radio"/></td> <td><input type="radio"/></td> <td><input type="radio"/></td> </tr> </table>	PIN	ASC0	MUX1	MUX2	MUX3	Charge		Last	<input checked="" type="radio"/>	<input checked="" type="radio"/>	<input checked="" type="radio"/>	<input checked="" type="radio"/>	<input checked="" type="radio"/>	<input type="radio"/>	<input type="radio"/>	<input type="radio"/>
PIN	ASC0	MUX1	MUX2	MUX3	Charge		Last										
<input checked="" type="radio"/>	<input checked="" type="radio"/>	<input checked="" type="radio"/>	<input checked="" type="radio"/>	<input checked="" type="radio"/>	<input type="radio"/>	<input type="radio"/>	<input type="radio"/>										

### Parameter Description

<b>&lt;storage&gt;</b> <sup>(str)</sup>	
“FD”	Fixed dialing phonebook Capacity: depending on SIM card Location: SIM
“SM” <sup>(&amp;F)</sup>	SIM phonebook Capacity: depending on SIM card Location: SIM
“ON”	MSISDN list Capacity: depending on SIM card Location: SIM
“ME”	Mobile Equipment Phonebook Capacity: max. 250 entries Location: ME
“LD”	Last number dialed phonebook. Stores all voice call numbers dialed with ATD, but no data call numbers. Capacity: max. 10 entries Location: depending on SIM this phonebook may reside partly or completely in ME <a href="#">AT+CPBW</a> command is not applicable to this storage. The LD list can be deleted with <a href="#">AT^SDLD</a> or with <a href="#">AT^SPBD</a> .

---

"MC"	Missed (unanswered received) calls list Capacity: max. 10 entries Location: ME <a href="#">AT+CPBW</a> command is not applicable to this storage. The MC list can be deleted with <a href="#">AT^SPBD</a> .
"RC"	Received calls list Capacity: max. 10 entries Location: ME <a href="#">AT+CPBW</a> command is not applicable to this storage. The RC list can be deleted with <a href="#">AT^SPBD</a> .

`<used>(num)`

Value indicating the number of used locations in selected memory storage.

`<total>(num)`

Value indicating the maximum number of locations allowed in the selected memory storage.

### Notes

- Users should be aware that when using this AT command quickly after SIM PIN authentication the SIM data may not yet be accessible, resulting in a short delay before the requested AT command response is returned. See Section 18.1, [Restricted access to SIM data after SIM PIN authentication](#) for further detail.
- If the SIM card is changed, all records of the "MC", "RC" and "LD" phonebooks stored on the ME will be deleted automatically. If the same SIM is removed and reinserted, no automatic deletion is performed. Calls made after last switch-on will be lost from "MC", "RC" and "LD" phonebook, if the SIM is removed and reinserted during normal operation.



## 14.4 AT+CPBW Write into Phonebook

The [AT+CPBW](#) write command can be used to create, edit and delete a phonebook entry at a [<location>](#) of the active storage selected with [AT+CPBS](#).

If [<storage>](#)="FD" (SIM fixed dialing numbers) is selected, PIN2 authentication has to be performed prior to any write access.

The [AT+CPBW](#) test command returns the location range supported by the current storage, the maximum length of the [<number>](#) field, the range of supported [<type>](#) values and the maximum length of the [<text>](#) field. Note: The length may not be available while SIM storage is selected. If storage does not offer format information, the format list contains empty parentheses.

### Syntax

<p>Test Command</p> <pre>AT+CPBW=?</pre> <p>Response(s)</p> <pre>+CPBW: (1-&lt;maxloc&gt;), &lt;nlength&gt;, (list of supported &lt;type&gt;s), &lt;tlength&gt;</pre> <p>OK ERROR +CME ERROR</p>	<p>Write Command</p> <pre>AT+CPBW=[&lt;location&gt;][, &lt;number&gt;[[, &lt;type&gt;][, &lt;text&gt;]]]</pre> <p>Response(s)</p> <pre>OK ERROR +CME ERROR</pre>																
<p>Reference(s)</p> <p>GSM 07.07, GSM 04.08</p>	<table border="1"> <thead> <tr> <th>PIN</th> <th>ASC0</th> <th>MUX1</th> <th>MUX2</th> <th>MUX3</th> <th>Charge</th> <th></th> <th>Last</th> </tr> </thead> <tbody> <tr> <td><input checked="" type="radio"/></td> <td><input checked="" type="radio"/></td> <td><input checked="" type="radio"/></td> <td><input checked="" type="radio"/></td> <td><input checked="" type="radio"/></td> <td><input type="radio"/></td> <td><input type="radio"/></td> <td><input type="radio"/></td> </tr> </tbody> </table>	PIN	ASC0	MUX1	MUX2	MUX3	Charge		Last	<input checked="" type="radio"/>	<input checked="" type="radio"/>	<input checked="" type="radio"/>	<input checked="" type="radio"/>	<input checked="" type="radio"/>	<input type="radio"/>	<input type="radio"/>	<input type="radio"/>
PIN	ASC0	MUX1	MUX2	MUX3	Charge		Last										
<input checked="" type="radio"/>	<input checked="" type="radio"/>	<input checked="" type="radio"/>	<input checked="" type="radio"/>	<input checked="" type="radio"/>	<input type="radio"/>	<input type="radio"/>	<input type="radio"/>										

### Parameter Description

[<location>](#)<sup>(num)</sup>

Location number within phonebook memory. The maximum range supported by each storage type is indicated in the test command response. If [<location>](#) is not given, the first free entry will be used.

If [<location>](#) is given as the only parameter, the phonebook entry specified by [<location>](#) is deleted.

[<number>](#)<sup>(str)</sup>

Phone number in format specified by [<type>](#). Parameter must be present, although it may be an empty string. Alphabetic characters are not permitted. [<number>](#) may contain dialstring modifiers "\*", "#" or "+".

If other printable non-alphabetic characters are used the entry needs to be saved with [<type>](#)=209. Otherwise, if [<type>](#)=209 is not used any non-digit characters other than "\*", "#" or "+" will be removed from the string and only accepted modifiers from the GSM alphabet will be saved.

A [<number>](#) saved with [<type>](#)=209 requires double memory. In order to fit into a standard location, the number needs to be reduced to a maximum length of [<nlength>/2](#), including all digits and dial string modifiers. Extended locations may be used as stated below for [<nlength>](#).

`<type>`<sup>(num)</sup>

Type of address octet, which defines the used type of number (ton) and the numbering plan identification (npi). Please consider that for types other than 129 or 145 dialing from phonebook with `ATD<mem><n>` is, depending on the network, not always possible (refer GSM 04.08 subclause 10.5.4.7 for details).

If `<type>` is not specified the unknown `<type>=129` is used. If `<number>` contains a leading "+" `<type>=145` (international) is used.

Supported values are:

145	Dialing string <code>&lt;number&gt;</code> includes international access code character "+"
161	National number. The network support for this type is optional.
209	Dialing string <code>&lt;number&gt;</code> will be saved as ASCII string. This is the default value, if <code>&lt;type&gt;</code> is not specified explicitly and characters other than "*", "#" or "+" are included in <code>&lt;number&gt;</code> . Note that phonebook entries saved with this type cannot be dialed.
255	Dialing string <code>&lt;number&gt;</code> is a command to control a Supplementary Service, i.e. "*", "#" codes are contained. Network support of this type is optional.
129	Unknown number. If <code>&lt;type&gt;</code> is unknown and the <code>&lt;number&gt;</code> contains a leading "+", then this sign is removed.

`<text>`<sup>(str)(+CSCS)</sup>

Text assigned to the phone number. The maximum length of this parameter is given in the test command response `<tlength>`. When using an ASCII terminal, characters which are coded differently in ASCII and GSM have to be entered via escape sequences as described in Section 1.5, [Supported character sets](#).

`<maxloc>`<sup>(num)</sup>

Maximum number of locations supported by the currently selected storage. For phonebooks located on SIM, this value varies depending on the SIM card. See [AT+CPBS](#) for typical values.

`<nlength>`<sup>(num)</sup>

Maximum length of phone number for "normal" locations. Depending on the storage, a limited number of locations with extended memory is available per phonebook. These locations allow storing numbers with twice the standard length, which is  $2 * \text{<nlength>}$  digits for normal numbers, but only `<nlength>` digits for numbers saved with parameter `<type>= 209`. If all extended locations of the selected phonebook are used up, then any attempt to write a number which requires extended memory will be denied with CME ERROR 260: INVALID DIAL STRING.

`<tlength>`<sup>(num)</sup>

Maximum length of `<text>` assigned to the telephone number. The value indicated by the test command is given in octets. If the `<text>` string is given in GSM characters, each character corresponds to one octet. If the `<text>` string is given in UCS2, the maximum number of characters depends on the coding scheme used for the alpha field of the SIM. In the worst case the number of UCS2 characters is at least one less than half the number of GSM characters.

For a detailed description please refer to GSM 11.11, Annex B [\[20\]](#).

### Note

- Users should be aware that when using this AT command quickly after SIM PIN authentication the SIM data may not yet be accessible, resulting in a short delay before the requested AT command response is returned. See Section 18.1, [Restricted access to SIM data after SIM PIN authentication](#) for further detail.

## Examples

### EXAMPLE 1

Make a new phonebook entry at the first free location

```
AT+CPBW=,"+431234567",145,"international"
```

### EXAMPLE 2

Delete entry at location 1

```
AT+CPBW=1
```

### EXAMPLE 3

The following examples are provided to illustrate the effect of writing phonebook entries with different types of dial string modifiers in [<number>](#)

```
AT+CPBW=5,"12345678",,"Arthur"  
AT+CPBW=6,"432!+-765()&54*654#",,"John"  
AT+CPBW=7,"432!+-765()&54*654#",129,"Eve"  
AT+CPBW=8,"432!+-765()&54*654#",145,"Tom"  
AT+CPBW=9,"432!+-765()&54*654#",209,"Richard"
```

### EXAMPLE 4

Read phonebook entries from locations 5 - 9 via [AT+CPBR](#)



```
+CPBR:5,"12345678",129,"Arthur"  
+CPBR:6,"432!+-765()&54*654#",209,"John"  
+CPBR:7,"432+76554*654#",129,"Eve"  
+CPBR:8,"+432+76554*654#",145,"Tom"  
+CPBR:9,"432!+-765()&54*654#",209,"Richard"
```

## 14.5 AT^SPBC Find first matching entry in sorted phonebook

The `AT^SPBC` write command searches the current phonebook for the index number of the first (lowest) entry that matches the character specified with `<schar>`. The `AT^SPBC` test command returns the list of phonebooks which can be searched through with `AT^SPBC`.

CAUTION: Please note that `AT^SPBC` is assigned the same index as `AT^SPBG` or `AT^SPBS` which is not identical with the physical location numbers used in the various phonebooks. Therefore, do not use the index numbers retrieved with `AT^SPBC` to dial out or modify phonebook entries.

### Syntax

<p>Test Command</p> <pre>AT^SPBC=?</pre> <p>Response(s)</p> <pre>^SPBC: "FD","SM","ME" OK ERROR +CME ERROR</pre>	<p>Write Command</p> <pre>AT^SPBC=&lt;schar&gt;</pre> <p>Response(s)</p> <pre>^spbc: &lt;index&gt; OK ERROR +CME ERROR</pre>																
<p>Reference(s)</p> <pre>--</pre>	<table border="1"> <thead> <tr> <th>PIN</th> <th>ASC0</th> <th>MUX1</th> <th>MUX2</th> <th>MUX3</th> <th>Charge</th> <th></th> <th>Last</th> </tr> </thead> <tbody> <tr> <td><input checked="" type="checkbox"/></td> <td><input checked="" type="checkbox"/></td> <td><input checked="" type="checkbox"/></td> <td><input checked="" type="checkbox"/></td> <td><input checked="" type="checkbox"/></td> <td><input type="checkbox"/></td> <td><input type="checkbox"/></td> <td><input type="checkbox"/></td> </tr> </tbody> </table>	PIN	ASC0	MUX1	MUX2	MUX3	Charge		Last	<input checked="" type="checkbox"/>	<input checked="" type="checkbox"/>	<input checked="" type="checkbox"/>	<input checked="" type="checkbox"/>	<input checked="" type="checkbox"/>	<input type="checkbox"/>	<input type="checkbox"/>	<input type="checkbox"/>
PIN	ASC0	MUX1	MUX2	MUX3	Charge		Last										
<input checked="" type="checkbox"/>	<input checked="" type="checkbox"/>	<input checked="" type="checkbox"/>	<input checked="" type="checkbox"/>	<input checked="" type="checkbox"/>	<input type="checkbox"/>	<input type="checkbox"/>	<input type="checkbox"/>										

### Parameter Description

`<schar>`<sup>(str)(+CSCS)</sup>

First character of the entry to be searched in the sorted list of phonebook entries. Search algorithms follow the sorting algorithms referenced in Section 14.1, [Sort Order for Phonebooks](#).

`<index>`<sup>(num)</sup>

In the active phonebook, the first (lowest) index number of an entry beginning with `<schar>`. As stated above, the retrieved index number shall not be used to dial out or edit phonebook entries. If no matching phonebook entry is found, `<index>=0` will be returned.

### Note

- Users should be aware that when using this AT command quickly after SIM PIN authentication the SIM data may not yet be accessible, resulting in a short delay before the requested AT command response is returned. See Section 18.1, [Restricted access to SIM data after SIM PIN authentication](#) for further detail.



## 14.6 AT^SPBD Purge phonebook memory storage

AT^SPBD can be used to purge the selected phonebook <storage> manually, i.e. all entries stored in the selected phonebook storage will be deleted. CAUTION! The operation cannot be stopped nor reversed!

The AT^SPBD test command returns the list of phonebooks which can be deleted with AT^SPBD.

An automatic purge of the phonebooks is performed when the SIM card is removed and replaced with a different SIM card. This affects the ME based part of the "LD" storage, and storages "MC" and "RC". Storage "ME" is not affected.

### Syntax

<p>Test Command</p> <p>AT^SPBD=?</p> <p>Response(s)</p> <p>^SPBD: list of supported &lt;storage&gt;s</p> <p>OK</p> <p>+CME ERROR</p>																	
<p>Write Command</p> <p>AT^SPBD=&lt;storage&gt;</p> <p>Response(s)</p> <p>OK</p> <p>+CME ERROR</p>																	
<p>Reference(s)</p> <p>--</p>	<table border="1"> <thead> <tr> <th>PIN</th> <th>ASC0</th> <th>MUX1</th> <th>MUX2</th> <th>MUX3</th> <th>Charge</th> <th></th> <th>Last</th> </tr> </thead> <tbody> <tr> <td><input checked="" type="radio"/></td> <td><input checked="" type="radio"/></td> <td><input checked="" type="radio"/></td> <td><input checked="" type="radio"/></td> <td><input checked="" type="radio"/></td> <td><input type="radio"/></td> <td><input type="radio"/></td> <td><input type="radio"/></td> </tr> </tbody> </table>	PIN	ASC0	MUX1	MUX2	MUX3	Charge		Last	<input checked="" type="radio"/>	<input checked="" type="radio"/>	<input checked="" type="radio"/>	<input checked="" type="radio"/>	<input checked="" type="radio"/>	<input type="radio"/>	<input type="radio"/>	<input type="radio"/>
PIN	ASC0	MUX1	MUX2	MUX3	Charge		Last										
<input checked="" type="radio"/>	<input checked="" type="radio"/>	<input checked="" type="radio"/>	<input checked="" type="radio"/>	<input checked="" type="radio"/>	<input type="radio"/>	<input type="radio"/>	<input type="radio"/>										

### Parameter Description

<storage><sup>(str)</sup>

If test command: List of phonebooks which can be deleted by AT^SPBD.

If write command: Phonebook to be deleted.

For a detailed description of storages see AT+CPBS.

"FD"	Fixed dialing phonebook (to delete this phonebook, PIN2 authentication must be performed first)
"SM" <sup>(&amp;F)</sup>	SIM phonebook
"ON"	MSISDN list
"ME"	Mobile Equipment Phonebook
"LD"	Last number dialed phonebook
"MC"	Missed (unanswered received) calls list
"RC"	Received calls list

### Note

- Users should be aware that when using this AT command quickly after SIM PIN authentication the SIM data may not yet be accessible, resulting in a short delay before the requested AT command response is returned. See Section 18.1, [Restricted access to SIM data after SIM PIN authentication](#) for further detail.

## 14.7 AT^SPBG Display phonebook entries in alphabetical order

AT^SPBG sorts the entries of the current phonebook in alphabetical order by name (the first six characters matter). The sort order is described in Section 14.1, [Sort Order for Phonebooks](#).

CAUTION: Please note that the sorted entries are assigned an index of their own which is not identical with the location numbers used in the various phonebooks.

Therefore, the AT^SPBG command can be used for reading only. For example, it helps you find entries starting with matching characters. However, do not use the listed index numbers to dial out or modify entries.

Before using the AT^SPBG write command it is recommended to query the number of records currently stored in the active phonebook (refer to test command parameter <used>). The test command also includes the parameters <nlength> and <tlength>. Note that if SIM storage is selected the length may not be available. If storage does not offer format information, the format list should be empty parentheses.

### Syntax

<p>Test Command</p> <pre>AT^SPBG=?</pre> <p>Response(s)</p> <pre>^SPBG: (1-&lt;used&gt;), &lt;nlength&gt;, &lt;tlength&gt; OK ERROR +CME ERROR</pre>	<p>Write Command</p> <pre>AT^SPBG=&lt;index1&gt;[, &lt;index2&gt;]</pre> <p>Response(s)</p> <pre>[^SPBG: &lt;index1&gt;, &lt;number&gt;, &lt;type&gt;, &lt;text&gt;] [^SPBG: &lt;index2&gt;, &lt;number&gt;, &lt;type&gt;, &lt;text&gt;] OK ERROR +CME ERROR</pre>
<p>Reference(s)</p> <pre>--</pre>	

### Parameter Description

<index1><sup>(num)</sup>

First index number in the sorted list where to start reading. The supported range is given in the test command response.

If <index 1> exceeds the upper bound <used>, "+CME ERROR: "invalid index" will be returned.

<index2><sup>(num)</sup>

Last index number in the sorted list where to stop reading. The supported range is given in the test command response.

If <index2> is not given via write command, only the entry located at <index1> will be displayed.

If both <index1> and <index2> are in the range indicated by the test command parameter <used>, the list of entries will be output and terminated with OK.

If <index2> exceeds the range indicated by the test command parameter <used>, the list of entries will be output but terminated with a "+CME ERROR: "invalid index".

<number><sup>(str)</sup>

String type phone number in format specified by <type>.

The number parameter may be an empty string.

`<type>`<sup>(num)</sup>

Type of address octet, which defines the used type of number (ton) and the numbering plan identification (npi). Please consider that for types other than 129 or 145 dialing from phonebook with `ATD<mem><n>` is, depending on the network, not always possible (refer to GSM 04.08 subclause 10.5.4.7 for details). See also `<type>` of `AT+CPBW`.

Possible values are:

145	Dialing string <code>&lt;number&gt;</code> includes international access code character '+'
161	National number. Network support of this type is optional.
209	Dialing string <code>&lt;number&gt;</code> has been saved as ASCII string and includes non-digit characters other than "*", "#" or "+". Note that phonebook entries saved with this type cannot be dialed.
255	Dialing string <code>&lt;number&gt;</code> is a command to control a Supplementary Service, i.e. "*", "#" codes are contained. Network support of this type is optional.
129	Otherwise

`<text>`<sup>(str)(+CSCS)</sup>

Text assigned to the phone number. The maximum length for this parameter is given in test command response `<tlength>`.

`<used>`<sup>(num)</sup>

Value indicating the number of used locations in selected memory storage.

`<nlength>`<sup>(num)</sup>

Maximum length of phone number for "normal" locations. Depending on the storage, a limited number of locations with extended memory is available per phonebook. Please refer to AT command `AT+CPBW` for detail.

`<tlength>`<sup>(num)</sup>

Maximum length of `<text>` assigned to the telephone number. The value indicated by the test command is given in octets. If the `<text>` string is given in GSM characters, each character corresponds to one octet. If the `<text>` string is given in UCS2, the maximum number of characters depends on the coding scheme used for the alpha field of the SIM according to GSM 11.11, Annex B [20]. In the worst case the number of UCS2 characters is at least one less than half the number of GSM characters.

### Notes

- The command can be used for the phonebooks "SM", "FD", "ME" (cf. `AT+CPBS`).
- Users should be aware that when using this AT command quickly after SIM PIN authentication the SIM data may not yet be accessible, resulting in a short delay before the requested AT command response is returned. See Section 18.1, [Restricted access to SIM data after SIM PIN authentication](#) for further detail.

### Example

Using `AT^SPBG` to obtain a sorted list of phonebook entries:

```
AT^SPBG=?
^SPBG: (1-33),20,17
AT^SPBG=1,33
^SPBG:1,"+999999",145,"Arthur"
^SPBG:2,"+777777",145,"Bill"
^SPBG:3,"+888888",145,"Charlie"
.....
```

First run the `AT^SPBG` test command to find out the range of entries stored in the current phonebook. TA returns the range, where 33 is the number of entries stored in the current phonebook. Now, enter the write command. To obtain best results it is recommended to query the full range of entries. TA returns phonebook entries in alphabetical order.

## 14.8 AT^SPBS Step through the selected phonebook alphabetically

AT^SPBS can be used to scroll sequentially through the active phonebook records in alphabetical order by name. Three entries will be displayed at a time.

Every time the write command is executed, 3 rows of phonebook records are returned. Each triplet overlaps with the next one. The actual index depends on parameter <value>. This parameter determines whether the index will be increased or decreased.

If the index in one output line reaches the last index in the alphabetical list, the next output line will display the first list entry.

After the last record of the phonebook has been reached (see parameter <used> for AT^SPBG), the <internal-counter> switches over to the first.

See examples below.

### Syntax

<p>Test Command</p> <pre>AT^SPBS=?</pre> <p>Response(s)</p> <pre>^SPBS: (list of supported &lt;value&gt;) OK</pre>	<p>Write Command</p> <pre>AT^SPBS=&lt;value&gt;</pre> <p>Response(s)</p> <pre>^SPBS: &lt;index-a&gt;, &lt;number&gt;, &lt;type&gt;, &lt;text&gt; ^SPBS: &lt;index-b&gt;, &lt;number&gt;, &lt;type&gt;, &lt;text&gt; ^SPBS: &lt;index-c&gt;, &lt;number&gt;, &lt;type&gt;, &lt;text&gt; OK +CME ERROR</pre>
<p>Reference(s)</p> <pre>--</pre>	

### Parameter Description

<value> <sup>(num)</sup>	
1	To make a step forward in the alphabetically sorted phonebook.
2	To make a step backward in the alphabetically sorted phonebook.
<index-a> <sup>(num)</sup>	
1...maxindex	<p>The index in the sorted list of phonebook entries that identifies the first entry in alphabetical order of names displayed.</p> <p>The value of &lt;index-a&gt; is determined by the value of the internal counter and by parameter &lt;value&gt;.</p> <p>After a write command has terminated successfully with "OK", the value from parameter &lt;index-a&gt; is saved and retained as the new internal counter value.</p> <p>Mind after the last record of phonebook, the first entry follows.</p>
<index-b> <sup>(num)</sup>	
1...maxindex	<p>The index in the sorted list of phonebook entries that identifies the second entry in alphabetical order of names displayed.</p> <p>Mind after the last record of phonebook, the first entry follows.</p>



<index-c><sup>(num)</sup>

1...maxindex                      The index in the sorted list of phonebook entries that identifies the third entry in alphabetical order of names displayed.  
Mind after the last record of phonebook, the first entry follows.

<number><sup>(str)</sup>

String type phone number in format specified by <type>.  
the number parameter may be an empty string.

<type><sup>(num)</sup>

Type of address octet, which defines the used type of number (ton) and the numbering plan identification (npi). Please consider that for types other than 129 or 145 dialing from phonebook with [ATD<mem><n>](#) is, depending on the network, not always possible (refer to GSM 04.08 subclause 10.5.4.7 for details). See also <type> of [AT+CPBW](#).

Possible values are:

145	Dialing string <number> includes international access code character '+'
161	National number. Network support of this type is optional.
209	Dialing string <number> has been saved as ASCII string and includes non-digit characters other than "*", "#" or "+". Note that phonebook entries saved with this type cannot be dialed.
255	Dialing string <number> is a command to control a Supplementary Service, i.e. "*", "#" codes are contained. Network support of this type is optional.
129	Otherwise

<text><sup>(str)(+CSCS)</sup>

Text assigned to the phone number.

<internal-counter><sup>(num)</sup>

0(&F)...maxindex                      This parameter is only an internal parameter and cannot be modified directly.  
The internal counter will be reset to index 0 after a call to [ATZ](#) or [AT&F](#).

### Notes

- The complete list of sorted entries can be retrieved using AT command [AT^SPBG](#).
- The command can be used for the phonebooks "SM", "FD", "ME" (cf. [AT+CPBS](#)).
- Users should be aware that when using this AT command quickly after SIM PIN authentication the SIM data may not yet be accessible, resulting in a short delay before the requested AT command response is returned. See Section [18.1, Restricted access to SIM data after SIM PIN authentication](#) for further detail.

### Examples

#### EXAMPLE 1

This example illustrates how to search down and up again using [AT^SPBS=1](#) and 2:

```
at&f
OK
at^spbs=1
^SPBS:27,"+999999",145,"Arthur"
^SPBS:6,"+777777",145,"Bill"
^SPBS:15,"+888888",145,"Charlie"
OK
```

First, [AT&F](#) is issued to make sure that [AT^SPBS=1](#) starts from the first character in alphabetical order.

```
at^spbs=1
^SPBS:6,"+777777",145,"Bill"
^SPBS:15,"+888888",145,"Charlie"
^SPBS:4,"0304444444",129,"Esther"

OK
at^spbs=1
^SPBS:15,"+888888",145,"Charlie"
^SPBS:4,"0304444444",129,"Esther"
^SPBS:23,"0303333333",129,"Harry"

OK
at^spbs=2
^SPBS:6,"+777777",145,"Bill"
^SPBS:15,"+888888",145,"Charlie"
^SPBS:4,"0304444444",129,"Esther"

OK
```

EXAMPLE 2

This example shows that when the last index in the sorted list has been reached, the internal counter overflows to the first index.

```
at&f                                Reset internal counter to 0.
OK
at^spbs=2                            Step down one entry starting from (internal
^SPBS:9,"+49301234567",145,"TomTailor" counter)=0 - overflow occurs.
^SPBS:27,"+999999",145,"Arthur"
^SPBS:6,"+777777",145,"Bill"

OK
```

## 14.9 AT^SDLD Delete the 'last number redial' memory

[AT^SDLD](#) deletes all numbers stored in the "LD" memory.

### Syntax

Test Command	AT^SDLD=?
Response(s)	OK
Exec Command	AT^SDLD
Response(s)	OK ERROR +CME ERROR: <err>
Reference(s)	--

PIN	ASC0	MUX1	MUX2	MUX3	Charge		Last
●	●	●	●	●	○	○	○

### Note

- Users should be aware that when using this AT command quickly after SIM PIN authentication the SIM data may not yet be accessible, resulting in a short delay before the requested AT command response is returned. See Section 18.1, [Restricted access to SIM data after SIM PIN authentication](#) for further detail.

## 15. Audio Commands

The AT Commands described in this chapter are related to the TC35i's audio interface.

### 15.1 Audio programming model

The following figure illustrates how the signal path can be adjusted with the parameters `<inCalibrate>`, `<inBbcGain>`, `<outBbcGain>`, `<outCalibrate[n]>` and `<sideTone>` as well as `<io>`, `<mic>` and `<ep>`.

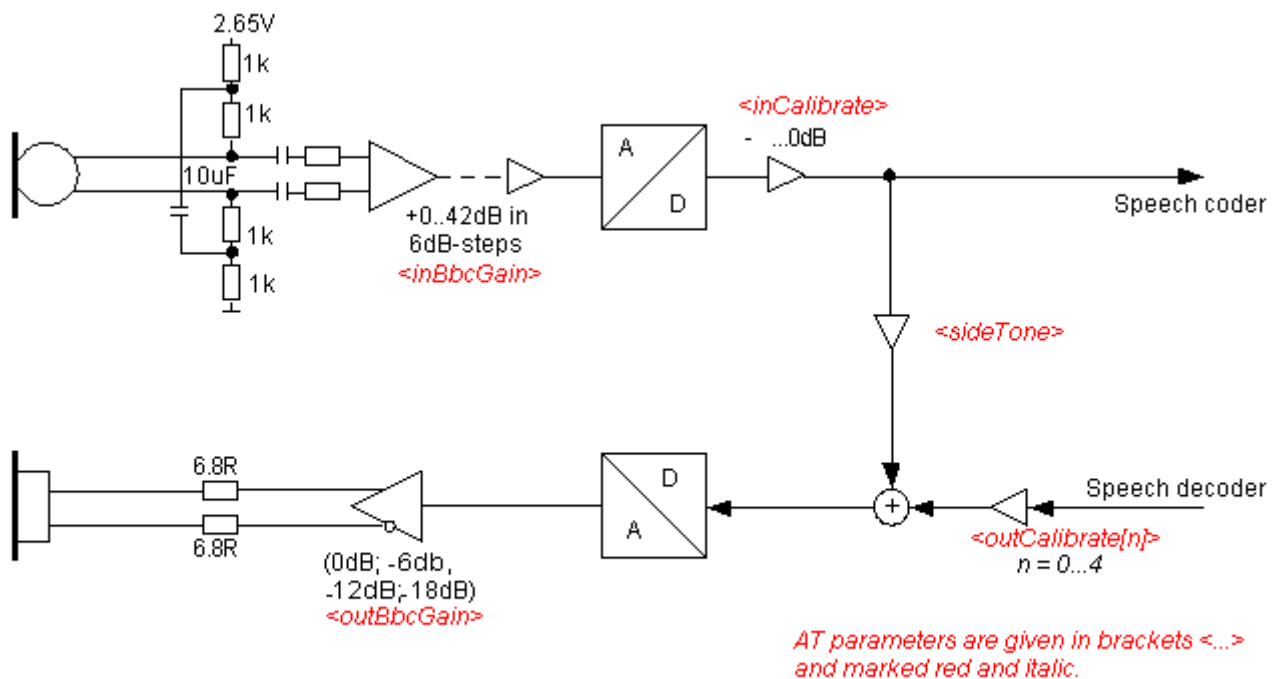

Figure 15.1: Audio programming model

## 15.2 ATL Set monitor speaker loudness

ATL is implemented for V.250ter compatibility reasons only, and has no effect. In multiplex mode (refer AT+CMUX) the command is supported on logical channel 1 only.

### Syntax

Exec Command								
ATL[<val>]								
Response(s)								
OK								
Reference(s)	PIN	ASC0	MUX1	MUX2	MUX3	Charge	⚡	Last
V.250	<input type="radio"/>	<input checked="" type="radio"/>	<input checked="" type="radio"/>	<input type="radio"/>	<input type="radio"/>	<input type="radio"/>	<input type="radio"/>	<input type="radio"/>

### Parameter Description

<val><sup>(num)</sup>

## 15.3 ATM Set monitor speaker mode

ATM is implemented for V.250ter compatibility reasons only, and has no effect. In multiplex mode (refer AT+CMUX) the command is supported on logical channel 1 only.

### Syntax

Exec Command								
ATM[<val>]								
Response(s)								
OK								
Reference(s)	PIN	ASC0	MUX1	MUX2	MUX3	Charge	⚡	Last
V.250	<input type="radio"/>	<input checked="" type="radio"/>	<input checked="" type="radio"/>	<input type="radio"/>	<input type="radio"/>	<input type="radio"/>	<input type="radio"/>	<input type="radio"/>

### Parameter Description

<val><sup>(num)</sup>

## 15.4 AT+CLVL Loudspeaker volume level

### Syntax

<p>Test Command</p> <pre>AT+CLVL=?</pre> <p>Response(s)</p> <pre>+CLVL: (list of supported&lt;level&gt;s) OK</pre>																	
<p>Read Command</p> <pre>AT+CLVL?</pre> <p>Response(s)</p> <pre>+CLVL: &lt;level&gt; OK ERROR +CME ERROR: &lt;err&gt;</pre>																	
<p>Write Command</p> <pre>AT+CLVL=&lt;level&gt;</pre> <p>Response(s)</p> <pre>OK ERROR +CME ERROR: &lt;err&gt;</pre>																	
<p>Reference(s)</p> <p>GSM 07.07</p>	<table border="1"> <thead> <tr> <th>PIN</th> <th>ASC0</th> <th>MUX1</th> <th>MUX2</th> <th>MUX3</th> <th>Charge</th> <th></th> <th>Last</th> </tr> </thead> <tbody> <tr> <td><input type="radio"/></td> <td><input checked="" type="radio"/></td> <td><input checked="" type="radio"/></td> <td><input checked="" type="radio"/></td> <td><input checked="" type="radio"/></td> <td><input type="radio"/></td> <td><input type="radio"/></td> <td><input type="radio"/></td> </tr> </tbody> </table>	PIN	ASC0	MUX1	MUX2	MUX3	Charge		Last	<input type="radio"/>	<input checked="" type="radio"/>	<input checked="" type="radio"/>	<input checked="" type="radio"/>	<input checked="" type="radio"/>	<input type="radio"/>	<input type="radio"/>	<input type="radio"/>
PIN	ASC0	MUX1	MUX2	MUX3	Charge		Last										
<input type="radio"/>	<input checked="" type="radio"/>	<input checked="" type="radio"/>	<input checked="" type="radio"/>	<input checked="" type="radio"/>	<input type="radio"/>	<input type="radio"/>	<input type="radio"/>										

### Parameter Description

<p>&lt;level&gt;<sup>(num)</sup></p> <p>Loudspeaker Volume Level</p> <p>0...4<sup>(D)</sup></p>
---

### Notes

- The write command can only be used in audio mode 2 - 6.
- The values of the volume steps are specified with the parameters <outCalibrate>[0],...<outCalibrate>[4] of the AT^SNFO command.
- As an alternative to AT+CLVL, you can use AT^SNFO and AT^SNFV. The parameter <level> is identical with <outStep> used by both commands.
- Any change to <level> (or <outStep>) takes effect in audio modes 2 to 6. That is, when you change <level> (or <outStep>) and then select another mode with AT^SNFS, the same step will be applied. The only exception is audio mode 1 which is fixed to <level>=4 (or accordingly <outStep>=4).
- <level> (or <outStep>) is stored non-volatile when the ME is powered down with AT^SMSO or reset with AT+CFUN=1,1.

## 15.5 AT+CMUT Mute control

The **AT+CMUT** command mutes the microphone input. The command can be used in all audio modes (1 to 6) and during a voice call only. See **AT^SNFS** for more details on the various audio modes. As alternative, you can use the **AT^SNFM** command.

During an active call, users should be aware that when they switch back and forth between different audio modes (for example handsfree on/off) the value of **<mute>** does not change, i.e. the microphone mode is retained until explicitly changed.

### Syntax

<p>Test Command</p> <p>AT+CMUT=?</p> <p>Response(s)</p> <p>+CMUT: (list of supported&lt;mute&gt;s)</p> <p>OK</p>																	
<p>Read Command</p> <p>AT+CMUT?</p> <p>Response(s)</p> <p>+CMUT: &lt;mute&gt;</p> <p>OK</p> <p>ERROR</p> <p>+CME ERROR: &lt;err&gt;</p>																	
<p>Write Command</p> <p>AT+CMUT=&lt;mute&gt;</p> <p>Response(s)</p> <p>OK</p> <p>ERROR</p> <p>+CME ERROR: &lt;err&gt;</p>																	
<p>Reference(s)</p> <p>GSM 07.07</p>	<table border="1"> <tr> <td>PIN</td> <td>ASC0</td> <td>MUX1</td> <td>MUX2</td> <td>MUX3</td> <td>Charge</td> <td></td> <td>Last</td> </tr> <tr> <td><input type="radio"/></td> <td><input checked="" type="radio"/></td> <td><input checked="" type="radio"/></td> <td><input checked="" type="radio"/></td> <td><input checked="" type="radio"/></td> <td><input type="radio"/></td> <td><input type="radio"/></td> <td><input type="radio"/></td> </tr> </table>	PIN	ASC0	MUX1	MUX2	MUX3	Charge		Last	<input type="radio"/>	<input checked="" type="radio"/>	<input checked="" type="radio"/>	<input checked="" type="radio"/>	<input checked="" type="radio"/>	<input type="radio"/>	<input type="radio"/>	<input type="radio"/>
PIN	ASC0	MUX1	MUX2	MUX3	Charge		Last										
<input type="radio"/>	<input checked="" type="radio"/>	<input checked="" type="radio"/>	<input checked="" type="radio"/>	<input checked="" type="radio"/>	<input type="radio"/>	<input type="radio"/>	<input type="radio"/>										



### Parameter Description

<b>&lt;mute&gt;</b> <sup>(num)</sup>	
0 <sup>(P)</sup>	Mute off
1	Mute on

## 15.6 AT+VTD Tone duration

This command refers to an integer `<duration>` that defines the length of tones transmitted with the `AT+VTS` command.

### Syntax

<p>Test Command</p> <p>AT+VTD=?</p> <p>Response(s)</p> <p>+VTD: (list of supported&lt;duration&gt;s)</p> <p>OK</p>																	
<p>Read Command</p> <p>AT+VTD?</p> <p>Response(s)</p> <p>&lt;duration&gt;</p> <p>OK</p>																	
<p>Write Command</p> <p>AT+VTD=&lt;duration&gt;</p> <p>Response(s)</p> <p>OK</p> <p>ERROR</p> <p>+CME ERROR</p>																	
<p>Reference(s)</p> <p>GSM 07.07</p>	<table border="1"> <thead> <tr> <th>PIN</th> <th>ASC0</th> <th>MUX1</th> <th>MUX2</th> <th>MUX3</th> <th>Charge</th> <th></th> <th>Last</th> </tr> </thead> <tbody> <tr> <td><input type="radio"/></td> <td><input checked="" type="radio"/></td> <td><input checked="" type="radio"/></td> <td><input checked="" type="radio"/></td> <td><input checked="" type="radio"/></td> <td><input type="radio"/></td> <td><input type="radio"/></td> <td><input type="radio"/></td> </tr> </tbody> </table>	PIN	ASC0	MUX1	MUX2	MUX3	Charge		Last	<input type="radio"/>	<input checked="" type="radio"/>	<input checked="" type="radio"/>	<input checked="" type="radio"/>	<input checked="" type="radio"/>	<input type="radio"/>	<input type="radio"/>	<input type="radio"/>
PIN	ASC0	MUX1	MUX2	MUX3	Charge		Last										
<input type="radio"/>	<input checked="" type="radio"/>	<input checked="" type="radio"/>	<input checked="" type="radio"/>	<input checked="" type="radio"/>	<input type="radio"/>	<input type="radio"/>	<input type="radio"/>										

### Parameter Description

`<duration>`<sup>(num)</sup>

Duration of the DTMF signal in 1/10 seconds with tolerance.  
The minimum duration of DTMF signals is 300ms. DTMF tones below 300ms cannot be generated.

1(&F)(P) ...255



## 15.7 AT+VTS DTMF and tone generation

**AT+VTS** is intended to send ASCII characters or strings which cause the Mobile Switching Center (MSC) to transmit DTMF tones to a remote subscriber. The command can only be used during active voice calls and offers the following variants:

- **AT+VTS=<dtmfString>** allows to send a sequence of DTMF tones with a duration defined with **AT+VTD**.
- **AT+VTS=<dtmf>[,<duration>]** allows to send a single DTMF tone. In this case, the duration can be individually determined during the call.

### Syntax

<p>Test Command</p> <p>AT+VTS=?</p> <p>Response(s)</p> <p>+VTS: (list of supported&lt;dtmf&gt;s), (list of supported&lt;duration&gt;s)</p> <p>OK</p>																	
<p>Write Command</p> <p>AT+VTS=&lt;dtmfString&gt;</p> <p>Response(s)</p> <p>OK</p>																	
<p>Write Command</p> <p>AT+VTS=&lt;dtmf&gt;[,&lt;duration&gt;]</p> <p>Response(s)</p> <p>OK</p> <p>ERROR</p> <p>+CME ERROR</p>																	
<p>Reference(s)</p> <p>GSM 07.07</p>	<table border="1"> <thead> <tr> <th>PIN</th> <th>ASC0</th> <th>MUX1</th> <th>MUX2</th> <th>MUX3</th> <th>Charge</th> <th></th> <th>Last</th> </tr> </thead> <tbody> <tr> <td><input type="radio"/></td> <td><input checked="" type="radio"/></td> <td><input checked="" type="radio"/></td> <td><input checked="" type="radio"/></td> <td><input checked="" type="radio"/></td> <td><input type="radio"/></td> <td><input type="radio"/></td> <td><input type="radio"/></td> </tr> </tbody> </table>	PIN	ASC0	MUX1	MUX2	MUX3	Charge		Last	<input type="radio"/>	<input checked="" type="radio"/>	<input checked="" type="radio"/>	<input checked="" type="radio"/>	<input checked="" type="radio"/>	<input type="radio"/>	<input type="radio"/>	<input type="radio"/>
PIN	ASC0	MUX1	MUX2	MUX3	Charge		Last										
<input type="radio"/>	<input checked="" type="radio"/>	<input checked="" type="radio"/>	<input checked="" type="radio"/>	<input checked="" type="radio"/>	<input type="radio"/>	<input type="radio"/>	<input type="radio"/>										

### Parameter Description

**<dtmfString>**<sup>(str)</sup>

String of ASCII characters in the set 0-9,#,\*,A, B, C, D. Maximal length of the string is 29. The string must be enclosed in quotation marks ("...").

**<dtmf>**<sup>(str)</sup>

ASCII character in the set 0...9,#,\*, A, B, C, D.

**<duration>**<sup>(num)</sup>

Tone duration in 1/10 seconds with tolerance. If not specified current setting of **AT+VTD** is used. The minimum duration of DTMF signals is 300ms. DTMF tones below 300ms cannot be generated.

1...255

## 15.8 AT^SAIC Audio Interface Configuration

AT^SAIC configures the interface connections of the active audio mode. Please keep in mind that the TC35i Terminal has only one analog audio interface.

The write command is usable in audio modes 2 to 6 only.

If AT^SNFS=1, any attempt to use AT^SAIC write command is rejected with error response. This is because all default parameters in audio mode 1 are determined for type approval and are not adjustable.

To allocate a specific audio mode to one of the audio interfaces, first select the audio mode with AT^SNFS and then choose the interface using AT^SAIC.

### Syntax

```

Test Command
AT^SAIC=?
Response(s)
^SAIC: (list of supported <io>s), (list of supported<mic>s), (list of supported<ep>s)
OK

Read Command
AT^SAIC?
Response(s)
^SAIC: <io>, <mic>, <ep>
OK

Write Command
AT^SAIC=<io>[, <mic>[, <ep>]]
Response(s)
OK
ERROR
+CME ERROR: operation not allowed

Reference(s)
--
PIN ASC0 MUX1 MUX2 MUX3 Charge Last
○ ● ● ● ● ○ ○ ○
    
```

### Parameter Description

<b>&lt;io&gt;</b> <sup>(num)</sup> (^SNFW)	
Input and output selection	
1	Not supported
2	Analog input and output
<b>&lt;mic&gt;</b> <sup>(num)</sup> (^SNFW)	
Microphone selection	
1	Microphone 1
2	Microphone 2
Not applicable to TC35i Terminal	
<b>&lt;ep&gt;</b> <sup>(num)</sup> (^SNFW)	
Select differential earpiece amplifier	
1	Selects the earpiece amplifier 1

- 
- |   |  |
|---|--|
| 2 | Selects the earpiece amplifier 2<br>Not applicable to the TC35i Terminal   |
| 3 | Selects both amplifiers. Note that both amplifiers are connected in parallel and therefore, get the same output power if <code>&lt;ep&gt;=3</code> .<br>Not applicable to the TC35i Terminal |

### Notes

- The factory defaults of `AT^SAIC` vary with the selected audio mode.  
If `AT^SNFS=1` or 4 or 5, then `AT^SAIC=2,1,1`.  
If `AT^SNFS=2` or 3 or 6, then `AT^SAIC=2,2,2`. (Although given by default, this setting applies to the TC35i module only, it cannot be used with the TC35i Terminal where the second audio interface is not connected. Nevertheless, you can configure TC35i Terminal for operation with audio modes 2, 3 or 6 by setting `AT^SAIC=2,1,1` instead. See examples provided with `AT^SNFS`.)  
`AT^SNFD` can be used to reset the factory defaults.
- For use after restart of the ME, you are advised to store the settings of `AT^SAIC` and `AT^SNFS` to the audio profile saved with `AT^SNFW`. Otherwise, audio mode 1 (`AT^SNFS=1`) and audio interface 2 (`AT^SAIC=2,1,1`) will be active each time the ME is powered up.

## 15.9 AT^SNFA Set or query of microphone attenuation

[AT^SNFA](#) specifies the large-scale attenuation on the microphone path of the audio device currently selected with [AT^SNFS](#). The write command is only available in audio modes 2 to 6.

### Syntax

<p>Test Command</p> <p>AT^SNFA=?</p> <p>Response(s)</p> <p>^SNFA: (list of supported &lt;atten&gt;s)</p> <p>OK</p>																	
<p>Read Command</p> <p>AT^SNFA?</p> <p>Response(s)</p> <p>^SNFA: &lt;atten&gt;</p> <p>OK</p>																	
<p>Write Command</p> <p>AT^SNFA=&lt;atten&gt;</p> <p>Response(s)</p> <p>OK</p> <p>ERROR</p> <p>CME ERROR: &lt;err&gt;</p>																	
<p>Reference(s)</p> <p>--</p>	<table border="1"> <tr> <td>PIN</td> <td>ASC0</td> <td>MUX1</td> <td>MUX2</td> <td>MUX3</td> <td>Charge</td> <td></td> <td>Last</td> </tr> <tr> <td><input type="radio"/></td> <td><input checked="" type="radio"/></td> <td><input checked="" type="radio"/></td> <td><input checked="" type="radio"/></td> <td><input checked="" type="radio"/></td> <td><input type="radio"/></td> <td><input type="radio"/></td> <td><input type="radio"/></td> </tr> </table>	PIN	ASC0	MUX1	MUX2	MUX3	Charge		Last	<input type="radio"/>	<input checked="" type="radio"/>	<input checked="" type="radio"/>	<input checked="" type="radio"/>	<input checked="" type="radio"/>	<input type="radio"/>	<input type="radio"/>	<input type="radio"/>
PIN	ASC0	MUX1	MUX2	MUX3	Charge		Last										
<input type="radio"/>	<input checked="" type="radio"/>	<input checked="" type="radio"/>	<input checked="" type="radio"/>	<input checked="" type="radio"/>	<input type="radio"/>	<input type="radio"/>	<input type="radio"/>										

### Parameter Description

<atten> <sup>(num)</sup> (^SNFW)	
Multiplication factor for input samples. Parameter <atten> is identical with <inCalibrate> of <a href="#">AT^SNFI</a> . Formula used to calculate microphone attenuation (negative gain): Gain in dB = 20 * log(<atten>/32768)	
0...32767 <sup>(P)</sup> ...65535	
0	Microphone is muted. Please note that <a href="#">AT^SNFA</a> cannot be used to mute the microphone. Therefore, any attempt to enter 0 will be rejected with error response. Value 0 is returned only by the read command <a href="#">AT^SNFA?</a> after the microphone was muted with <a href="#">AT^SNFM=0</a> during an active call.
32767	No attenuation on the microphone path Values greater than 32767 will be suppressed to 32767.

### Notes

- This command is provided for compatibility with former products (e.g. M20) and is a subset of [AT^SNFI](#). The parameter <inCalibrate> of [AT^SNFI](#) is identical with <atten> of [AT^SNFA](#).
- To make the changes persistent use [AT^SNFW](#).

**Example**

```
^SYSSTART
at^snfa=?
^SNFA: (0-65535)
OK
at^snfa?
^SNFA: 32767
OK
at^snfs=4
OK
at^snfa=1
OK
at^snfa?
^SNFA: 1
OK
at^snfi?
^SNFI: 5,1
OK
at^snfi=5,45
OK
at^snfa?
^SNFA: 45
OK
```

## 15.10 AT^SNFD Set audio parameters to manufacturer default values

AT^SNFD sets the active audio parameters to manufacturer defined default values.  
The restored values are:

AT^SNFA: <atten>

AT^SNFI: <inBbcGain>, <inCalibrate>

AT^SNFO: <outBbcGain>, <outCalibrate>[0 to 4], <sideTone>

AT^SAIC: <io>, <mic>, <ep>

AT^SNFS: <audMode>

### Syntax

Test Command	AT^SNFD=?
Response(s)	OK
Exec Command	AT^SNFD
Response(s)	OK
Reference(s)	--

PIN	ASC0	MUX1	MUX2	MUX3	Charge		Last
<input type="radio"/>	<input checked="" type="radio"/>	<input checked="" type="radio"/>	<input checked="" type="radio"/>	<input checked="" type="radio"/>	<input type="radio"/>	<input type="radio"/>	<input type="radio"/>

### Note

- Remember that the factory set audio mode 1 is fixed to <outStep>=4. Consequently, AT^SNFD restores <audMode> together with <outStep>=4, but does not affect the values of <outStep> currently selected in audio modes 2 - 6. This means, if <audMode>=1, the read commands AT^SNFO, AT^SNFV and AT+CLVL will always deliver <outStep>=4. In all other modes the <outStep> value is retained until explicitly changed.

## 15.11 AT^SNFG Generate Tone

The `AT^SNFG` write command generates a 'local tone' via the selected audio output device. Beside the duration up to 3 combinations of frequency and amplitude can be used to compose a local tone.

### Syntax

Test Command

```
AT^SNFG=?
```

Response(s)

```
^SNFG:(list of supported <duration>s), (list of supported <frequency>s), (list of supported <amplitude>s)[, ...]
```

```
OK
```

Write Command

```
AT^SNFG=<duration>, <frequency>, <amplitude>[, <frequency>, <amplitude>[, <frequency>, <amplitude>]]
```

Response(s)

```
OK
```

```
ERROR
```

Reference(s)

```
--
```

PIN	ASC0	MUX1	MUX2	MUX3	Charge		Last
<input type="radio"/>	<input checked="" type="radio"/>	<input checked="" type="radio"/>	<input checked="" type="radio"/>	<input checked="" type="radio"/>	<input type="radio"/>	<input type="radio"/>	<input type="radio"/>

### Parameter Description

`<duration>`<sup>(num)</sup>

in Milliseconds.

0...65535

0 Mutes the currently played tone immediately.

65535 Activates a tone with infinit duration.

`<frequency>`<sup>(num)</sup>

in Hertz

0...4000

to be input in 10Hz steps. Audible bandwidth is limited due to the voice band filters at 150Hz-3800Hz.

`<amplitude>`<sup>(num)</sup>

of the tone generator belonging to a frequency.

0...32767

The output level at the speaker is dependent of the `<outBbcGain>` value (see [AT^SNFO](#)).

If more than one tone should be played, each amplitude level will be divided by the number of running tones to avoid overdriving of the internal amplifier. for example, if three tones with amplitude of 30000 units should be generated each amplitude is reduced to 10000.

### Notes

- Response of the command is always "OK" as long as the input parameters are valid.
- If more than one pair of `<frequency>` and `<amplitude>` is used then the amplitude for each frequency is divided by the number of pairs.
- Tone priorities  
Ring tones (incoming call/short message), Supervisory tones, Call Progress tones, Battery tones, RTC tones and DTMF tones always have higher priority than a local tone. This means a local tone will be played only if no module tone with a higher priority is being played. A local tone will be stopped and ended when a tone or melody from the module starts to play.
- To suspend a local tone from playing use "AT^SNFG=0".
- Switching the tone generator on and off will trigger `AT+CIND` indicator "so under" depending on current `AT+CMER` settings.
- If there is a voice call active then the local tone is mixed into the voice signal. In case of a multi party call the local tones are not available.



## 15.12 AT^SNFI Set microphone path parameters

AT^SNFI controls the microphone path amplification. Read and write options of this command refer to the active audio mode. The write command works only in audio modes 2 to 6.

### Syntax

<p>Test Command</p> <pre>AT^SNFI=?</pre> <p>Response(s)</p> <pre>^SNFI: (list of supported &lt;inBbcGain&gt;s) , (list of supported &lt;inCalibrate&gt;s) OK</pre>																	
<p>Read Command</p> <pre>AT^SNFI?</pre> <p>Response(s)</p> <pre>^SNFI: &lt;inBbcGain&gt; , &lt;inCalibrate&gt; OK</pre>																	
<p>Write Command</p> <pre>AT^SNFI=&lt;inBbcGain&gt; , &lt;inCalibrate&gt;</pre> <p>Response(s)</p> <pre>OK</pre>																	
<p>Reference(s)</p> <pre>--</pre>	<table border="1"> <tr> <td>PIN</td> <td>ASC0</td> <td>MUX1</td> <td>MUX2</td> <td>MUX3</td> <td>Charge</td> <td></td> <td>Last</td> </tr> <tr> <td><input type="radio"/></td> <td><input checked="" type="radio"/></td> <td><input checked="" type="radio"/></td> <td><input checked="" type="radio"/></td> <td><input checked="" type="radio"/></td> <td><input type="radio"/></td> <td><input type="radio"/></td> <td><input type="radio"/></td> </tr> </table>	PIN	ASC0	MUX1	MUX2	MUX3	Charge		Last	<input type="radio"/>	<input checked="" type="radio"/>	<input checked="" type="radio"/>	<input checked="" type="radio"/>	<input checked="" type="radio"/>	<input type="radio"/>	<input type="radio"/>	<input type="radio"/>
PIN	ASC0	MUX1	MUX2	MUX3	Charge		Last										
<input type="radio"/>	<input checked="" type="radio"/>	<input checked="" type="radio"/>	<input checked="" type="radio"/>	<input checked="" type="radio"/>	<input type="radio"/>	<input type="radio"/>	<input type="radio"/>										

### Parameter Description

<inBbcGain><sup>(num)(^SNFW)</sup>  
ADC gain adjustable in eight 6 dB steps from 0 dB to 42 dB (0=0dB, 7=42dB, 8 steps of 6 dB).  
0...7

<inCalibrate><sup>(num)(^SNFW)</sup>  
Multiplication factor for input samples. Formula to calculate the negative gain (attenuation) of the input signal:  
Gain in dB = 20 \* log (inCalibrate / 32768)  
0...32767

### Notes

- The range of <inCalibrate> is up to 65535 but will be suppressed to 32767. Values above <inCalibrate>= 65535 will cause a failure.
- The parameter <inCalibrate> of AT^SNFI is identical with <atten> of AT^SNFA.
- For use after restart, changed values can be stored with AT^SNFW.
- Attention! When you adjust audio parameters avoid exceeding the maximum allowed level. Bear in mind that exposure to excessive levels of noise can cause physical damage to users!

## 15.13 AT^SNFM Mute microphone

### Syntax

<p>Test Command</p> <p>AT^SNFM=?</p> <p>Response(s)</p> <p>^SNFM: (list of supported &lt;mute&gt;s)</p> <p>OK</p>																	
<p>Read Command</p> <p>AT^SNFM?</p> <p>Response(s)</p> <p>^SNFM: &lt;mute&gt;</p> <p>OK</p>																	
<p>Write Command</p> <p>AT^SNFM=&lt;mute&gt;</p> <p>Response(s)</p> <p>OK</p>																	
<p>Reference(s)</p> <p>--</p>	<table border="1"> <tr> <td>PIN</td> <td>ASC0</td> <td>MUX1</td> <td>MUX2</td> <td>MUX3</td> <td>Charge</td> <td></td> <td>Last</td> </tr> <tr> <td><input type="radio"/></td> <td><input checked="" type="radio"/></td> <td><input checked="" type="radio"/></td> <td><input checked="" type="radio"/></td> <td><input checked="" type="radio"/></td> <td><input type="radio"/></td> <td><input type="radio"/></td> <td><input type="radio"/></td> </tr> </table>	PIN	ASC0	MUX1	MUX2	MUX3	Charge		Last	<input type="radio"/>	<input checked="" type="radio"/>	<input checked="" type="radio"/>	<input checked="" type="radio"/>	<input checked="" type="radio"/>	<input type="radio"/>	<input type="radio"/>	<input type="radio"/>
PIN	ASC0	MUX1	MUX2	MUX3	Charge		Last										
<input type="radio"/>	<input checked="" type="radio"/>	<input checked="" type="radio"/>	<input checked="" type="radio"/>	<input checked="" type="radio"/>	<input type="radio"/>	<input type="radio"/>	<input type="radio"/>										

### Command Description

The test command returns the supported values of the parameter <mute>.  
 The read command returns whether the microphone is on or off during voice calls.  
 The write command can be used to mute or activate the microphone during voice calls.

### Parameter Description

<mute> <sup>(num)</sup>	
0	Mute microphone
1 <sup>(P)</sup>	Microphone on

### Notes

- The write command works in all audio modes but only during active voice calls.
- This command can be used in all audio modes (1 to 6) and during a voice call only. See [AT^SNFS](#) for more details on the various audio modes.
- During an active call, users should be aware that when they switch back and forth between different audio modes (for example handsfree on/off) the value of <mute> does not change, i.e. the microphone mode is retained until explicitly changed.
- As alternative, you can use the [AT+CMUT](#) command.

## 15.14 AT^SNFO Set audio output (= loudspeaker path) parameter

AT^SNFO controls the earpiece path amplification. The read and write commands refer to the active audio mode. The write command works only in audio modes 2 to 6.

### Syntax

<p>Test Command</p> <p>AT^SNFO=?</p> <p>Response(s)</p> <p>^SNFO: (list of supported &lt;outBbcGain&gt;s), (list of supported &lt;outCalibrate&gt;s), (list of supported &lt;outStep&gt;s), (list of supported &lt;sideTone&gt;s)</p> <p>OK</p>																	
<p>Read Command</p> <p>AT^SNFO?</p> <p>Response(s)</p> <p>^SNFO: &lt;outBbcGain&gt;, &lt;outCalibrate&gt;[0], &lt;outCalibrate&gt;[1], &lt;outCalibrate&gt;[2], &lt;outCalibrate&gt;[3], &lt;outCalibrate&gt;[4], &lt;outStep&gt;, &lt;sideTone&gt;</p> <p>OK</p>																	
<p>Write Command</p> <p>AT^SNFO=&lt;outBbcGain&gt;, &lt;outCalibrate&gt;[0], &lt;outCalibrate&gt;[1], &lt;outCalibrate&gt;[2], &lt;outCalibrate&gt;[3], &lt;outCalibrate&gt;[4], &lt;outStep&gt;, &lt;sideTone&gt;</p> <p>Response(s)</p> <p>OK</p>																	
<p>Reference(s)</p> <p>--</p>	<table border="1"> <tr> <td>PIN</td> <td>ASC0</td> <td>MUX1</td> <td>MUX2</td> <td>MUX3</td> <td>Charge</td> <td></td> <td>Last</td> </tr> <tr> <td><input type="radio"/></td> <td><input checked="" type="radio"/></td> <td><input checked="" type="radio"/></td> <td><input checked="" type="radio"/></td> <td><input checked="" type="radio"/></td> <td><input type="radio"/></td> <td><input type="radio"/></td> <td><input type="radio"/></td> </tr> </table>	PIN	ASC0	MUX1	MUX2	MUX3	Charge		Last	<input type="radio"/>	<input checked="" type="radio"/>	<input checked="" type="radio"/>	<input checked="" type="radio"/>	<input checked="" type="radio"/>	<input type="radio"/>	<input type="radio"/>	<input type="radio"/>
PIN	ASC0	MUX1	MUX2	MUX3	Charge		Last										
<input type="radio"/>	<input checked="" type="radio"/>	<input checked="" type="radio"/>	<input checked="" type="radio"/>	<input checked="" type="radio"/>	<input type="radio"/>	<input type="radio"/>	<input type="radio"/>										

### Parameter Description

<p>&lt;outBbcGain&gt;<sup>(num)(^SNFW)</sup></p> <p>Negative DAC gain (attenuation) adjustable in four 6 dB steps from 0 dB to -18 dB (0=0 dB, 3=-18 dB)</p> <p>0...3</p>
<p>&lt;outCalibrate&gt;<sup>(num)(^SNFW)</sup></p> <p>Formula to calculate the value of the 5 volume steps selectable with parameter &lt;outStep&gt;: Attenuation = 20 * log (2 * outCalibrate[n] / 32768)</p> <p>0...32767</p>
<p>&lt;outStep&gt;<sup>(num)</sup></p> <p>Volume steps 0 - 4, each defined with outCalibrate[n]</p> <p>0...[4]</p>
<p>&lt;sideTone&gt;<sup>(num)(^SNFW)</sup></p> <p>Multiplication factor for the sidetone gain. Formula to calculate how much of the original microphone signal is added to the earpiece signal: Sidetone gain in dB = 20 * log (sideTone / 32768).</p> <p>0...32767</p>

## Notes

- `<outCalibrate>` specifies the amount of volume of each `<outStep>`. The range of each `<outCalibrate>` is up to 65535, but will be suppressed to 32767. A value above `<outCalibrate>=65535` will cause an error.
- The range of `<sideTone>` is up to 65535, but will be suppressed to 32767. A value above `<sideTone>=65535` will cause an error.
- Any change to `<outStep>` takes effect in audio modes 2 to 6. That is, when you change `<outStep>` and then select another mode with `AT^SNFS`, the same step will be applied. Nevertheless, the sound quality and the amount of volume are not necessarily the same, since all remaining audio parameters can use different values in either mode.
- Audio mode 1 is fixed to `<outStep>=4`. In this mode, any attempt to change `<outStep>` or other parameters returns an error.
- The value of `<outStep>` is stored non-volatile when the ME is powered down with `AT^SMSO` or reset with `AT+CFUN=x,1`. Any other parameters changed with `AT^SNFO` need to be saved with `AT^SNFW` for use after restart. See also `AT^SNFD` for details on restoring factory defaults.
- The values of `<outStep>` can also be changed with `AT^SNFV` and `AT+CLVL`.
- CAUTION! When you adjust audio parameters avoid exceeding the maximum allowed level. Bear in mind that exposure to excessive levels of noise can cause physical damage to users!

## 15.15 AT^SNFPT Set progress tones

[AT^SNFPT](#) controls the Call Progress Tones generated at the beginning of a mobile originated call setup. Please note that the setting is stored volatile, i.e. after restart or reset, the default value 1 will be restored.

### Syntax

<p>Test Command</p> <pre>AT^SNFPT=?</pre> <p>Response(s)</p> <pre>^SNFPT: (list of supported &lt;pt&gt;s) OK</pre>																	
<p>Read Command</p> <pre>AT^SNFPT?</pre> <p>Response(s)</p> <pre>^SNFPT: &lt;pt&gt; OK</pre>																	
<p>Write Command</p> <pre>AT^SNFPT=&lt;pt&gt;</pre> <p>Response(s)</p> <pre>OK</pre>																	
<p>Reference(s)</p> <pre>--</pre>	<table border="1"> <thead> <tr> <th>PIN</th> <th>ASC0</th> <th>MUX1</th> <th>MUX2</th> <th>MUX3</th> <th>Charge</th> <th></th> <th>Last</th> </tr> </thead> <tbody> <tr> <td><input type="radio"/></td> <td><input checked="" type="radio"/></td> <td><input checked="" type="radio"/></td> <td><input checked="" type="radio"/></td> <td><input checked="" type="radio"/></td> <td><input type="radio"/></td> <td><input type="radio"/></td> <td><input type="radio"/></td> </tr> </tbody> </table>	PIN	ASC0	MUX1	MUX2	MUX3	Charge		Last	<input type="radio"/>	<input checked="" type="radio"/>	<input checked="" type="radio"/>	<input checked="" type="radio"/>	<input checked="" type="radio"/>	<input type="radio"/>	<input type="radio"/>	<input type="radio"/>
PIN	ASC0	MUX1	MUX2	MUX3	Charge		Last										
<input type="radio"/>	<input checked="" type="radio"/>	<input checked="" type="radio"/>	<input checked="" type="radio"/>	<input checked="" type="radio"/>	<input type="radio"/>	<input type="radio"/>	<input type="radio"/>										

### Parameter Description

<pt> <sup>(num)</sup>	Description
0	Disables Call Progress Tones
1 <sup>(P)</sup>	Enables Call Progress Tones (audible tones shortly heard on the phone when ME starts to set up a call.)

## 15.16 AT^SNFS Select audio hardware set

The `AT^SNFS` write command serves to set the audio mode required for the connected equipment. `AT^SNFS` can also be used in conjunction with `AT^SAIC`. This is useful, for example, if the audio interfaces are operated alternatively to benefit from different devices. Each audio mode can be assigned a specific interface. To do so, first select the audio mode with `AT^SNFS`, then activate the audio interface with `AT^SAIC` and finally enter `AT^SNFW` to store the settings to your audio profile. To switch back and forth it is sufficient to use `AT^SNFS`.

### Syntax

<p>Test Command</p> <pre>AT^SNFS=?</pre> <p>Response(s)</p> <pre>^SNFS: (list of supported &lt;audMode&gt;s) OK</pre>																	
<p>Read Command</p> <pre>AT^SNFS?</pre> <p>Response(s)</p> <pre>^SNFS: &lt;audMode&gt; OK</pre>																	
<p>Write Command</p> <pre>AT^SNFS=&lt;audMode&gt;</pre> <p>Response(s)</p> <pre>OK ERROR CME ERROR: &lt;err&gt;</pre>																	
<p>Reference(s)</p> <pre>--</pre>	<table border="1"> <tr> <td>PIN</td> <td>ASC0</td> <td>MUX1</td> <td>MUX2</td> <td>MUX3</td> <td>Charge</td> <td></td> <td>Last</td> </tr> <tr> <td><input type="radio"/></td> <td><input checked="" type="radio"/></td> <td><input checked="" type="radio"/></td> <td><input checked="" type="radio"/></td> <td><input checked="" type="radio"/></td> <td><input type="radio"/></td> <td><input type="radio"/></td> <td><input type="radio"/></td> </tr> </table>	PIN	ASC0	MUX1	MUX2	MUX3	Charge		Last	<input type="radio"/>	<input checked="" type="radio"/>	<input checked="" type="radio"/>	<input checked="" type="radio"/>	<input checked="" type="radio"/>	<input type="radio"/>	<input type="radio"/>	<input type="radio"/>
PIN	ASC0	MUX1	MUX2	MUX3	Charge		Last										
<input type="radio"/>	<input checked="" type="radio"/>	<input checked="" type="radio"/>	<input checked="" type="radio"/>	<input checked="" type="radio"/>	<input type="radio"/>	<input type="radio"/>	<input type="radio"/>										

### Parameter Description

<audMode> <sup>(num)</sup> (^SNFW)	
[1]	<p>Audio mode 1: Standard mode optimized for the reference handset, that can be connected to the analog interface 1 ( see "TC35 i Hardware Interface Description" for information on this handset.) To adjust the volume use the knob of the reference handset. In audio mode 4, this handset can be used with user defined parameters.</p> <p>Note: The default parameters are determined for type approval and are not adjustable with AT commands.</p> <p><code>AT^SNFD</code> restores <code>&lt;audMode&gt; 1</code>.</p>
2	<p>Audio mode 2: Customer specific mode for a basic handsfree (speakerphone) device (Siemens Car Kit Portable).</p> <p>Analog interface 2 is assumed as default.</p>
3	<p>Audio mode 3: Customer specific mode for a mono-headset.</p> <p>Analog interface 2 is assumed as default.</p>
4	<p>Audio mode 4: Customer specific mode for a user handset.</p> <p>Analog interface 1 is assumed as default.</p>
5	<p>Audio mode 5: Customer specific mode.</p> <p>Analog interface 1 is assumed as default.</p>
6	<p>Audio mode 6: Customer specific mode.</p> <p>Analog interface 2 is assumed as default.</p>

## Notes

- The write command can be used during a voice call to switch back and forth between different modes. This allows the user, for example, to switch handsfree operation (speakerphone) on and off.
- Users should be aware that `<outStep>` is a global setting. This means, when another audio mode is selected during a call, the value of `<outStep>` does not change. This is also true for mute operation which can be set with `AT^SNFM` or `AT+CMUT`: If the microphone is muted and the user selects another audio mode during the call, then the microphone remains muted until explicitly changed. Exception: In audio mode 1 `<outStep>=4` is fix.
- For use after restart of the module, you are advised to store the selected mode to the audio profile saved with `AT^SNFW`. Otherwise, audio mode 1 will be active each time the module is powered up.

## Examples

### EXAMPLE 1

Suppose a user wishes to use alternatively a handsfree device (speakerphone) and a handset. The handset can be connected to the first analog interface and adjusted to audio mode 4. The handsfree device can be attached to the second analog interface and adjusted to audio mode 2. The factory defaults of `AT^SAIC` need not be changed.

Settings for the handset:

```
AT^SNFS=4
OK
AT^SAIC?                               Factory default of AT^SAIC assigned to audio mode 4.
^SAIC: 2,1,1
OK
```

Settings for the handsfree device:

```
AT^SNFS=2
OK
AT^SAIC?                               Factory default of AT^SAIC assigned to audio mode 2.
^SAIC: 2,2,2
OK
```

To store the configuration to the user defined audio profile:

```
AT^SNFW                               Stores the audio mode and the interface.
OK
```

To switch back and forth:

```
AT^SNFS=4                               Switches to the handset connected to analog interface 1.
OK
AT^SNFS=2                               Switches to the handsfree device at analog interface 2.
OK
```

### EXAMPLE 2

The following example illustrates a combination of a handset and a handsfree device connected to other interfaces than those assumed as factory default.

Settings for a handset connected to the second analog interface and adjusted to audio mode 4:

```
AT^SNFS=4
OK
AT^SAIC=2,2,2
OK
```

Settings for a handsfree device connected to the first analog interface and adjusted to audio mode 2:

```
AT^SNFS=2
OK
AT^SAIC=2,1,1
OK
```

To store the configuration to the user defined audio profile:

---

AT^SNFW OK	Stores the audio mode and the interface.
---------------	--

To switch back and forth:

AT^SNFS=4 OK	Switches to the handset connected to analog interface 1.
AT^SNFS=2 OK	Switches to the handsfree device at analog interface 2.



## 15.17 AT^SNFV Set loudspeaker volume

[AT^SNFV](#) can be used to set the volume of the loudspeaker to the value [<outCalibrate>](#) addressed by [<outStep>](#). The read and write commands refer to the active audio mode. The write command works only in audio modes 2 to 6.

### Syntax

<p>Test Command</p> <p>AT^SNFV=?</p> <p>Response(s)</p> <p>^SNFV: (list of supported <a href="#">&lt;outStep&gt;</a>s)</p> <p>OK</p>																	
<p>Read Command</p> <p>AT^SNFV?</p> <p>Response(s)</p> <p>^SNFV: <a href="#">&lt;outStep&gt;</a></p> <p>OK</p>																	
<p>Write Command</p> <p>AT^SNFV=<a href="#">&lt;outStep&gt;</a></p> <p>Response(s)</p> <p>OK</p> <p>ERROR</p> <p>+CME ERROR</p>																	
<p>Reference(s)</p> <p>--</p>	<table border="1"> <thead> <tr> <th>PIN</th> <th>ASC0</th> <th>MUX1</th> <th>MUX2</th> <th>MUX3</th> <th>Charge</th> <th></th> <th>Last</th> </tr> </thead> <tbody> <tr> <td><input type="radio"/></td> <td><input checked="" type="radio"/></td> <td><input checked="" type="radio"/></td> <td><input checked="" type="radio"/></td> <td><input checked="" type="radio"/></td> <td><input type="radio"/></td> <td><input type="radio"/></td> <td><input type="radio"/></td> </tr> </tbody> </table>	PIN	ASC0	MUX1	MUX2	MUX3	Charge		Last	<input type="radio"/>	<input checked="" type="radio"/>	<input checked="" type="radio"/>	<input checked="" type="radio"/>	<input checked="" type="radio"/>	<input type="radio"/>	<input type="radio"/>	<input type="radio"/>
PIN	ASC0	MUX1	MUX2	MUX3	Charge		Last										
<input type="radio"/>	<input checked="" type="radio"/>	<input checked="" type="radio"/>	<input checked="" type="radio"/>	<input checked="" type="radio"/>	<input type="radio"/>	<input type="radio"/>	<input type="radio"/>										

### Parameter Description

[<outStep>](#)<sup>(num)</sup>

The actual volume of each step is defined by the parameter [<outCalibrate>](#), which can be set with [AT^SNFO](#).  
0...4<sup>(P)</sup>

### Notes

- Any change to [<outStep>](#) takes effect in audio modes 2 to 6. That is, when you change [<outStep>](#) and then select another mode with [AT^SNFS](#), the same step will be applied. Nevertheless, the actual volume can be quite different, depending on the values of [<outCalibrate>](#) set in each mode. The only exception is audio mode 1 which is fixed to [<outStep>](#)=4.
- [<outStep>](#) is stored non-volatile when the ME is powered down with [AT^SMSO](#) or reset with [AT+CFUN=1,1](#). [<outStep>](#) is not stored by [AT^SNFW](#).
- [<outStep>](#) can also be changed by [AT^SNFO](#) (Section 15.14) and [AT+CLVL](#) (Section 15.4).

## 15.18 AT^SNFW Write audio setting in non-volatile store

AT^SNFW causes the TA to write the currently selected audio parameters to non-volatile store. The saved audio profile includes the following parameters:

AT^SNFA: <atten>



AT^SNFI: <inBbcGain>, <inCalibrate>

AT^SNFO: <outBbcGain>, <outCalibrate>[0 to 4], <sideTone>

AT^SNFS: <audMode>

AT^SAIC: <io>, <mic>, <ep>.

### Syntax

<p>Test Command</p> <p>AT^SNFW=?</p> <p>Response(s)</p> <p>OK</p>																	
<p>Exec Command</p> <p>AT^SNFW</p> <p>Response(s)</p> <p>OK</p> <p>ERROR</p> <p>CME ERROR: &lt;err&gt;</p>																	
<p>Reference(s)</p> <p>--</p>	<table border="1"> <thead> <tr> <th>PIN</th> <th>ASC0</th> <th>MUX1</th> <th>MUX2</th> <th>MUX3</th> <th>Charge</th> <th></th> <th>Last</th> </tr> </thead> <tbody> <tr> <td><input type="radio"/></td> <td><input checked="" type="radio"/></td> <td><input checked="" type="radio"/></td> <td><input checked="" type="radio"/></td> <td><input checked="" type="radio"/></td> <td><input type="radio"/></td> <td><input type="radio"/></td> <td><input type="radio"/></td> </tr> </tbody> </table>	PIN	ASC0	MUX1	MUX2	MUX3	Charge		Last	<input type="radio"/>	<input checked="" type="radio"/>	<input checked="" type="radio"/>	<input checked="" type="radio"/>	<input checked="" type="radio"/>	<input type="radio"/>	<input type="radio"/>	<input type="radio"/>
PIN	ASC0	MUX1	MUX2	MUX3	Charge		Last										
<input type="radio"/>	<input checked="" type="radio"/>	<input checked="" type="radio"/>	<input checked="" type="radio"/>	<input checked="" type="radio"/>	<input type="radio"/>	<input type="radio"/>	<input type="radio"/>										

## 15.19 AT^SRTC Ring tone configuration

The `AT^SRTC` read command returns the current `<type>` and current `<volume>`. The read command can be used while test playback is off or on. In the latter case, see execute command for details.

The `AT^SRTC` execute command is intended for testing. It starts to play a melody from the audio output currently selected with `AT^SNFS`. To deactivate test playback use `AT^SRTC` again. During test playback, you can enter the write command to select another melody and adjust the volume. Also, you can enter the read command to check the type and volume of the current ring tone, and to view the status of playback (on / off). The test ringing signal cannot be activated when an MTC is ringing (ERROR). Selecting `<volume>=0` during the test, immediately stops playback. After this, ring tones will be muted until you change `<volume>` using the write command.

The `AT^SRTC` write command chooses the type and volume of ring tones for the selected event. The settings can be changed no matter whether or not the ME is ringing. The selected type and volume are saved in the non-volatile Flash memory and, thus, are retained after Power Down. An exception is `<type>=0`, that can be entered to quickly mute the tone or melody currently played to indicate an event. `<type>=0` only stops immediately the audible ring tone, but does not terminate the URC that indicates the event (for example RING). No permanent settings are changed or saved.

### Syntax

<p>Test Command</p> <p><code>AT^SRTC=?</code></p> <p>Response(s)</p> <p><code>^SRTC: (list of supported) &lt;type&gt;s, (list of supported) &lt;volume&gt;s, (list of supported) &lt;event&gt;s</code></p> <p>OK</p>																	
<p>Read Command</p> <p><code>AT^SRTC?</code></p> <p>Response(s)</p> <p><code>^SRTC: &lt;type&gt; (of &lt;event&gt;=0) , &lt;volume&gt; (of &lt;event&gt;=0) , &lt;type&gt;(of &lt;event&gt;=1) , &lt;volume&gt;(of &lt;event&gt;=1), &lt;status&gt;</code></p> <p>OK</p>																	
<p>Exec Command</p> <p><code>AT^SRTC</code></p> <p>Response(s)</p> <p>OK</p>																	
<p>Write Command</p> <p><code>AT^SRTC=[&lt;type&gt;][, &lt;volume&gt;][, &lt;event&gt;]</code></p> <p>Response(s)</p> <p><code>^SRTC: &lt;type&gt;, &lt;volume&gt;</code></p> <p>OK</p> <p>ERROR</p>																	
<p>Reference(s)</p> <p>--</p>	<table border="1"> <thead> <tr> <th>PIN</th> <th>ASC0</th> <th>MUX1</th> <th>MUX2</th> <th>MUX3</th> <th>Charge</th> <th></th> <th>Last</th> </tr> </thead> <tbody> <tr> <td><input type="radio"/></td> <td><input checked="" type="radio"/></td> <td><input checked="" type="radio"/></td> <td><input checked="" type="radio"/></td> <td><input checked="" type="radio"/></td> <td><input type="radio"/></td> <td><input type="radio"/></td> <td><input type="radio"/></td> </tr> </tbody> </table>	PIN	ASC0	MUX1	MUX2	MUX3	Charge		Last	<input type="radio"/>	<input checked="" type="radio"/>	<input checked="" type="radio"/>	<input checked="" type="radio"/>	<input checked="" type="radio"/>	<input type="radio"/>	<input type="radio"/>	<input type="radio"/>
PIN	ASC0	MUX1	MUX2	MUX3	Charge		Last										
<input type="radio"/>	<input checked="" type="radio"/>	<input checked="" type="radio"/>	<input checked="" type="radio"/>	<input checked="" type="radio"/>	<input type="radio"/>	<input type="radio"/>	<input type="radio"/>										

### Parameter Description

**<type><sup>(num)</sup>**

Type of ring tone. You have a choice of 7 different ring tones and melodies. All will be played from the audio output selected with the [AT^SNFS](#) command. **<type>=0** is only intended for muting.

0	Mutes the currently played tone immediately.
1	Sequence 1
2	Sequence 2
3 <sup>(D)</sup>	Sequence 3
4	Sequence 4
5	Sequence 5
6	Sequence 6
7	Sequence 7

**<volume><sup>(num)</sup>**

Volume of ring tone, varies from low to high

0 <sup>(D)</sup>	Mute
1	Very low
2	Identical with 1
3	Low
4	Identical with 3
5	Middle
6	Identical with 5
7	High

**<status><sup>(num)</sup>**

Status of test ringing. Indicates whether or not a melody is currently being played back for testing

0	Switched off
1	Switched on

**<event><sup>(num)</sup>**

Event to be indicated. All settings of **<type>** and **<volume>** apply to the selected event only.

[0]	All MTCs (voice, data etc.)
1	Incoming short message

### Notes

- Before first using ring tones note that the following settings apply:  
We have chosen to let you decide your own preferences when you start using ring tones. Therefore, factory setting is [AT^SRTC=3,0,3,0,0](#) (ring tones are muted). To activate ring tones for the very first time, first enter the write command and simply change the volume. After applying a firmware update the volume and type selected before the firmware update will be preserved.
- The test ringing signal cannot be activated while an MTC is ringing (ERROR).
- If an MTC arrives during test playback, test ringing will be deactivated and "normal" ringing reactivated (RING). Likewise, an MOC will also stop test ringing.
- If no optional parameter is entered, the old value will be kept.
- The ring tone for SMS will be only played if the URC for incoming SMS is activated. See [AT+CNMI](#)

## 16. Hardware related Commands

The AT Commands described in this chapter are related to the TC35i's hardware interface. More information regarding this interface is available with the "TC35i Hardware Interface Description"[\[2\]](#).

### 16.1 AT+CALA Set alarm time

The [AT+CALA](#) write command can be used to set an alarm time in the ME. When the alarm time is reached and the alarm is executed the ME returns an Unsolicited Result Code (URC) and the alarm time is reset to "00/01/01,00:00:00".

The alarm can adopt two functions, depending on whether or not you switch the GSM engine off after setting the alarm:

- **Reminder message:** You can use the alarm function to generate reminder messages. For this purpose, set the alarm as described below and do not switch off or power down the ME. When executed the message comes as an Unsolicited Result Code which reads "+CALA".
- **Alarm mode:** You can use the alarm function to restart the ME when powered down. For this purpose, set the alarm as described below. Then power down the ME by entering the [AT^SMSO](#) command. When the alarm time is reached, the ME will wake up to Alarm mode. To prevent the ME from unintentionally logging into the GSM network, Alarm mode provides restricted operation. Upon wake-up, the ME indicates an Unsolicited Result Code which reads: "+CALA". A limited number of AT commands is available during Alarm mode, for details see Section [18.4, Availability of AT Commands Depending on Operating Mode of ME](#). The ME remains deregistered from the GSM network.

If you want the ME to return to full operation (normal operating mode) it is necessary to restart the ME by driving the ignition line (IGT pin of application interface) to ground.

If your ME is battery powered note that the battery can be charged while the ME stays in Alarm mode. For details please refer to [\[2\]](#).

The [AT+CALA](#) test command returns the supported array index values `<n>`, the supported alarm types `<type>` and the maximum length of the text `<tlength>` to be output.

The [AT+CALA](#) read command returns the current alarm settings in the ME.

#### Syntax

##### Test Command

```
AT+CALA=?
```

Response(s)

```
+CALA: (list of supported<n>s), (list of supported<type>s), (list of supported<tlength>s)
```

```
OK
```

```
ERROR
```

```
+CME ERROR: <err>
```

##### Read Command

```
AT+CALA?
```

Response(s)

```
+CALA: <time>[, <n>[, <type>[, <text>]]]
```

```
OK
```

```
ERROR
```

```
+CME ERROR: <err>
```

##### Write Command

```
AT+CALA=<time>[, <n>[, <type>[, <text>]]]
```

Response(s)

```
OK
```

Write Command	(Continued)																
AT+CALA=<time>[, <n>[, <type>[, <text>]]]																	
Response(s)																	
ERROR																	
+CME ERROR																	
Reference(s)																	
GSM 07.07																	
	<table border="1"> <thead> <tr> <th>PIN</th> <th>ASC0</th> <th>MUX1</th> <th>MUX2</th> <th>MUX3</th> <th>Charge</th> <th></th> <th>Last</th> </tr> </thead> <tbody> <tr> <td><input type="radio"/></td> <td><input checked="" type="radio"/></td> <td><input checked="" type="radio"/></td> <td><input checked="" type="radio"/></td> <td><input checked="" type="radio"/></td> <td><input checked="" type="radio"/></td> <td><input checked="" type="radio"/></td> <td><input type="radio"/></td> </tr> </tbody> </table>	PIN	ASC0	MUX1	MUX2	MUX3	Charge		Last	<input type="radio"/>	<input checked="" type="radio"/>	<input checked="" type="radio"/>	<input checked="" type="radio"/>	<input checked="" type="radio"/>	<input checked="" type="radio"/>	<input checked="" type="radio"/>	<input type="radio"/>
PIN	ASC0	MUX1	MUX2	MUX3	Charge		Last										
<input type="radio"/>	<input checked="" type="radio"/>	<input checked="" type="radio"/>	<input checked="" type="radio"/>	<input checked="" type="radio"/>	<input checked="" type="radio"/>	<input checked="" type="radio"/>	<input type="radio"/>										

### Unsolicited Result Codes

#### URC 1

+CALA: [ <text> ]

Indicates reminder message.

#### URC 2

^SYSSTART ALARM MODE

+CALA: <text>

Indicates ME wake-up into Alarm mode. If autobauding is active (AT+IPR=0) the line "+CALA" does not appear, but your individual <text> message will be displayed.

### Parameter Description

<time><sup>(str)</sup>

Format is "yy/MM/dd, hh:mm:ss". For example, 6th of July 2005, 22:10:00 equals to "05/07/06,22:10:00" (see also AT+CCLK).

Note: If <time> equals current date and time or is set to an earlier date, TA returns +CME ERROR: 21.

<n><sup>(num)</sup>

Integer type value indicating the array index of the alarm.

The ME allows to set only one alarm at a time. Therefore, the list of supported alarm events indicated by the test command AT+CALA=? is <n>=0. If a second alarm time is set, the previous alarm will be deleted. Therefore, the read command AT+CALA? will always return <n>=0. This is also true if individual settings are made on the various Multiplexer channels, for details see notes below.

<type><sup>(num)</sup>

Integer type value indicating the type of the alarm.

0 Alarm indication: text message via serial interface

<text><sup>(str)</sup>

String type value indicating the text to be displayed when alarm time is reached; maximum length is <tlength>. By factory default, <text> is undefined.

Note: <text> will be stored to the non-volatile flash memory when the device enters the Power Down mode via AT^SMSO. Once saved, it will be available upon next power-up, until you overwrite it by typing another text. This eliminates the need to enter the full string when setting a fresh alarm.

<text> should not contain characters which are coded differently in ASCII and GSM (e.g. umlauts), see also "Supported character sets" and "GSM alphabet tables".

<tlength><sup>(num)</sup>

Integer type value indicating the maximum length of <text>. The maximum length is 16.

## Notes

- After the alarm was executed the parameter `<time>` of `AT+CALA` will be reset to "00/01/01,00:00:00", but `<text>` will be preserved as described above.
- If TC35i is totally disconnected from power supply the most recently saved configuration of +CALA: `<time>[,<n>[,<type>[,<text>]]]` will be presented when TC35i is powered up.
- Each time TC35i is restarted with ignition it takes 2s to re-initialize the RTC and to update the current time. Therefore, it is recommended to wait 2s before using the commands `AT+CCLK` and `AT+CALA` (for example 2s after ^SYSSTART has been output).
- Alarm settings on different Multiplexer channels (see `AT+CMUX`):
  - On each interface an individual `<text>` message can be stored, but only one time setting applies. This means an alarm `<time>` set on one of the interfaces overwrites the time setting on all remaining interfaces. Therefore, the total number of alarm events returned by the read command `AT+CALA?` will always be `<n>=0`, no matter whether different text messages are stored.
  - When the scheduled alarm occurs, the ME sends the URC only on the interface where the most recent alarm setting was made. The alarm time will be reset to "00/01/01,00:00:00" on all interfaces.

## Examples

### EXAMPLE 1

You may want to configure a reminder message for July 31, 2005, at 9.30h, including the message "Good Morning".

```
AT+CALA="05/07/31,09:30:00",0,0,"Good Morning"  
OK
```

Do not switch off the GSM engine. When the alarm occurs the ME returns the following URC:

```
+CALA: Good Morning
```

### EXAMPLE 2

To set a fresh alarm using the same message as in Example 1, simply enter date and time. `<n>`, `<type>`, `<text>`, `<tlength>` can be omitted:

```
AT+CALA="05/07/31,08:50:00"  
OK
```

When the alarm is executed the URC comes with the same message:

```
+CALA: Good Morning
```

### EXAMPLE 3

To enable the ME to wake up into Alarm mode, e.g. on July 20, 2005, at 8.30h, enter

```
AT+CALA="05/07/20,08:30:00"  
OK
```

Next, power down the ME:



```
AT^SMSO  
^SMSO: MS OFF  
OK  
^SHUTDOWN
```

When the alarm is executed the ME wakes up to Alarm mode and displays a URC. If available, this line is followed by the individual `<text>` most recently saved. If no individual message was saved only the first line appears.

```
" +CALA "  
+CALA: Good Morning
```

## 16.2 AT+CCLK Real Time Clock

### Syntax

<p>Test Command</p> <pre>AT+CCLK=?</pre> <p>Response(s)</p> <pre>OK</pre>																	
<p>Read Command</p> <pre>AT+CCLK?</pre> <p>Response(s)</p> <pre>+CCLK: &lt;time&gt;</pre> <pre>OK</pre>																	
<p>Write Command</p> <pre>AT+CCLK=&lt;time&gt;</pre> <p>Response(s)</p> <pre>+CME ERROR: &lt;err&gt;</pre> <pre>ERROR</pre> <pre>OK</pre>																	
<p>Reference(s)</p> <pre>GSM 07.07</pre>	<table border="1"> <thead> <tr> <th>PIN</th> <th>ASC0</th> <th>MUX1</th> <th>MUX2</th> <th>MUX3</th> <th>Charge</th> <th></th> <th>Last</th> </tr> </thead> <tbody> <tr> <td><input type="radio"/></td> <td><input checked="" type="radio"/></td> <td><input checked="" type="radio"/></td> <td><input checked="" type="radio"/></td> <td><input checked="" type="radio"/></td> <td><input checked="" type="radio"/></td> <td><input checked="" type="radio"/></td> <td><input checked="" type="radio"/></td> </tr> </tbody> </table>	PIN	ASC0	MUX1	MUX2	MUX3	Charge		Last	<input type="radio"/>	<input checked="" type="radio"/>	<input checked="" type="radio"/>	<input checked="" type="radio"/>	<input checked="" type="radio"/>	<input checked="" type="radio"/>	<input checked="" type="radio"/>	<input checked="" type="radio"/>
PIN	ASC0	MUX1	MUX2	MUX3	Charge		Last										
<input type="radio"/>	<input checked="" type="radio"/>	<input checked="" type="radio"/>	<input checked="" type="radio"/>	<input checked="" type="radio"/>	<input checked="" type="radio"/>	<input checked="" type="radio"/>	<input checked="" type="radio"/>										

### Parameter Description

<time><sup>(str)</sup>

Format is "yy/mm/dd,hh:mm:ss", where the characters indicate the two last digits of the year, followed by month, day, hour, minutes, seconds; for example 6th of July 2005, 22:10:00 hours equals to "05/07/06,22:10:00"  
Factory default is "02/01/01,00:00:00"

### Notes

- <time> is retained if the device enters the Power Down mode via [AT^SMSO](#).
- <time> will be reset to its factory default if power is totally disconnected. In this case, the clock starts with <time>= "02/01/01,00:00:00" upon next power-up.
- Each time TC35i is restarted it takes 2s to re-initialize the RTC and to update the current time. Therefore, it is recommended to wait 2s before using the commands [AT+CCLK](#) and [AT+CALA](#) (for example 2s after ^SYSSTART has been output).



## 16.3 AT^SBC Battery charging / discharging and charge control

Responses returned by the [AT^SBC](#) command vary with the operating mode of the ME:

- Normal mode: ME is switched on by Ignition pin and running the SLEEP, IDLE, TALK or DATA mode. Charger is not connected. [AT^SBC](#) can be used to query the battery capacity and the power consumption of ME and application (if value of application was specified before as [<current>](#)).
- Normal mode + charging: Allows charging while ME is switched on by Ignition pin and running the SLEEP, IDLE, TALK or DATA mode. [AT^SBC](#) returns charger status and power consumption of ME / application. Percentage of battery capacity is not available.
- Charge-only mode: Allows charging while ME is detached from GSM network. When started, the mode is indicated by the URC "[^SYSSTART CHARGE-ONLY MODE](#)". [AT^SBC](#) returns charger status and power consumption of ME / application. Percentage of battery capacity is not available. In Charge-only mode a limited number of AT commands is accessible (see Section [18.4, Availability of AT Commands Depending on Operating Mode of ME](#)). There are several ways to activate the Charge-only mode:
  - from Power Down mode: Connect charger while ME was powered down with [AT^SMSO](#)
  - from Normal mode: Connect charger, then enter [AT^SMSO](#).
- Alarm mode: The battery can be charged while the ME stays in Alarm mode.

Charging begins once the charger connects to the POWER pins of the ZIF connector (except for the Alarm mode).

### Syntax

Test Command AT^SBC=? Response(s) ^SBC: (list of supported <a href="#">&lt;bcs&gt;</a> s), (list of supported <a href="#">&lt;bcl&gt;</a> s), (list of supported <a href="#">&lt;mpc&gt;</a> s) OK																	
Read Command AT^SBC? Response(s) ^SBC: <a href="#">&lt;bcs&gt;</a> , <a href="#">&lt;bcl&gt;</a> , <a href="#">&lt;mpc&gt;</a> OK ERROR +CME ERROR: <a href="#">&lt;err&gt;</a>																	
Write Command AT^SBC= <a href="#">&lt;current&gt;</a> Response(s) OK ERROR +CME ERROR: <a href="#">&lt;err&gt;</a>																	
Reference(s) --	<table border="1"> <thead> <tr> <th>PIN</th> <th>ASC0</th> <th>MUX1</th> <th>MUX2</th> <th>MUX3</th> <th>Charge</th> <th></th> <th>Last</th> </tr> </thead> <tbody> <tr> <td style="text-align: center;">○</td> <td style="text-align: center;">●</td> <td style="text-align: center;">●</td> <td style="text-align: center;">●</td> <td style="text-align: center;">●</td> <td style="text-align: center;">●</td> <td style="text-align: center;">●</td> <td style="text-align: center;">○</td> </tr> </tbody> </table>	PIN	ASC0	MUX1	MUX2	MUX3	Charge		Last	○	●	●	●	●	●	●	○
PIN	ASC0	MUX1	MUX2	MUX3	Charge		Last										
○	●	●	●	●	●	●	○										

## Unsolicited Result Codes

### URC 1

Undervoltage and overvoltage conditions will be reported by unsolicited result codes. The URCs need not be activated by the user, but will be output automatically when fault conditions occur. For further details regarding automatic shutdown and voltage ratings please refer to [2].

^SBC: Undervoltage

The URC will be reported, for example, when you attempt to make a call while the voltage is close to the critical limit and further power loss is caused during the transmit burst. To remind you that the battery needs to be charged soon, the URC appears several times in a minute before the module switches off. If the voltage drops quickly down to a value which is 50mV below the minimum threshold only one URC will be presented.

### URC 2

^SBC: Overvoltage warning

This URC is an alarm indicator displayed when the supply voltage approaches its maximum level. The URC appears only once.

### URC 3

^SBC: Overvoltage shutdown

This URC will be reported when the voltage exceeds the maximum level specified in the Hardware Interface Description. It appears only once before the module starts to perform an orderly shutdown.

In applications powered from Li-Ion batteries the incorporated protection circuit typically prevents overcharging, thus eliminating the risk of overvoltage conditions. Yet, in case of charging errors, for example caused by a bad battery or due to the absence of a battery protection circuit, the module's overvoltage shutdown function will take effect to avoid overcharging.

The automatic shutdown procedure caused by undervoltage or overvoltage is equivalent to the power-down initiated with the AT^SMSO command, i.e. ME logs off from the network and the software enters a secure state avoiding loss of data. When the module is in IDLE mode it takes typically one minute to deregister from the network and to switch off.

## Command Description

Use the write command to specify the power consumption of your external application. This information enables the ME to calculate the average power consumption <mpc> and to properly control the charging process. If the value is not correct the entire charging process may be affected. Resulting problems may be wrong responses to the AT^SBC read command, overcharging, or the battery does not reach full capacity. When the ME is powered down or reset, the value of <current> is restored to its default.

## Parameter Description

<bcs><sup>(num)</sup>

Connection status of charging adapter

0	No charging adapter is connected
1	Charging adapter is connected
2	Charging adapter is connected, charging in progress
3	Charging adapter is connected, charging has finished
4	Charging error, charging is interrupted
5	False charging temperature, charging is interrupted while temperature is beyond allowed range

<bc1><sup>(num)</sup>

Battery capacity

0, 20, 40, 60, 80, 100 percent of remaining capacity (6 steps)

0 indicates that either the battery is exhausted or the capacity value is not available

While charging is in progress (charging adapter connected) the battery capacity is not available. Consequently, parameter <bc1>=0. To query the battery capacity disconnect the charger.

<mpc><sup>(num)</sup>

Average power consumption.

Value (0..5000) of average power consumption (mean value over a couple of seconds) in mA.

<mpc> is obtained from the ME's power consumption, plus the value you have specified for the application by using the write command `AT^SBC=<current>`. Remember that the ME's power consumption varies with its operating mode (IDLE, TALK, DATA) and the power level.

If <current> was not yet specified and no battery pack NTC is detected <mpc> returns only the module's present power consumption.

If <current> was not yet specified, but the NTC of the connected battery pack is detected, an offset value of 200mA will, by default, be added. 200mA is an estimated value which represents the power consumption of a typical external application. Drawn from practical experience it serves as a precaution to ensure proper charging in case you have not entered <current>. It is strongly recommended that you enter the correct power consumption of your application as described below.

Note: If the battery does not incorporate an NTC, or the battery and the NTC are not compliant with the requirements specified in [2], the battery cannot be detected by the ME.

<current><sup>(num)</sup>

Enter the current consumption of your application in mA (0..5000). If used, the current provided over the by 2.9V VDD pin of the application interface (maximum 10mA) must be added, too.

## Notes



- If Multiplex mode is active, any virtual channel can be used to enter the write command and to specify <current>. The undervoltage URC appears simultaneously on all three channels.
- The URC "`^SYSSTART CHARGE-ONLY MODE`" is indicated automatically when the engine enters this mode (except when autobauding is active). Unlike the undervoltage and overvoltage URC, it cannot be disabled or enabled by the user.

## 16.4 AT^SBV Battery/Supply Voltage

The `AT^SBV` execute command allows to monitor the supply (or battery) voltage of the module. The voltage is continuously measured at intervals depending on the operating mode of the RF interface. The duration of a measurement period ranges from 0.5s in TALK / DATA mode up to 50s when TC35i is in IDLE mode or Limited Service (deregistered). The displayed value is averaged over the last measuring period before the `AT^SBV` command was executed.

The measurement is related to the test points of BATT+ and GND, both accessible on the bottom of the module. Refer to [1] for information on the module's test points.

### Syntax

<p>Test Command</p> <pre>AT^SBV=?</pre> <p>Response(s)</p> <pre>OK ERROR +CME ERROR:</pre>	<table border="1"> <thead> <tr> <th>PIN</th> <th>ASC0</th> <th>MUX1</th> <th>MUX2</th> <th>MUX3</th> <th>Charge</th> <th></th> <th>Last</th> </tr> </thead> <tbody> <tr> <td><input type="radio"/></td> <td><input checked="" type="radio"/></td> <td><input checked="" type="radio"/></td> <td><input checked="" type="radio"/></td> <td><input checked="" type="radio"/></td> <td><input checked="" type="radio"/></td> <td><input checked="" type="radio"/></td> <td><input checked="" type="radio"/></td> </tr> </tbody> </table>	PIN	ASC0	MUX1	MUX2	MUX3	Charge		Last	<input type="radio"/>	<input checked="" type="radio"/>	<input checked="" type="radio"/>	<input checked="" type="radio"/>	<input checked="" type="radio"/>	<input checked="" type="radio"/>	<input checked="" type="radio"/>	<input checked="" type="radio"/>
PIN		ASC0	MUX1	MUX2	MUX3	Charge		Last									
<input type="radio"/>	<input checked="" type="radio"/>	<input checked="" type="radio"/>	<input checked="" type="radio"/>	<input checked="" type="radio"/>	<input checked="" type="radio"/>	<input checked="" type="radio"/>	<input checked="" type="radio"/>										
<p>Exec Command</p> <pre>AT^SBV</pre> <p>Response(s)</p> <pre>^SBV: &lt;value&gt; OK ERROR +CME ERROR:</pre>																	
<p>Reference(s)</p> <pre>--</pre>																	

### Parameter Description

`<value>(num)`  
Supply (or battery) voltage in mV

## 16.5 AT^SCTM Set critical operating temperature presentation mode or query temperature

Use this command to monitor the temperature range of the module and the battery. The write command enables or disables the presentation of URCs to report critical temperature limits.

CAUTION: During the first 15 seconds after start-up, the module operates in an automatic report mode: URCs can be always displayed regardless of the selected mode [<n>](#).

### Syntax

<p>Test Command</p> <p>AT^SCTM=?</p> <p>Response(s)</p> <p>^SCTM: (list of supported <a href="#">&lt;n&gt;s</a>), (range of <a href="#">&lt;temp&gt;</a> in Celsius)</p> <p>OK</p>																	
<p>Read Command</p> <p>AT^SCTM?</p> <p>Response(s)</p> <p>^SCTM: <a href="#">&lt;n&gt;</a>, <a href="#">&lt;m&gt;</a>[, <a href="#">&lt;temp&gt;</a>]</p> <p>OK</p> <p>ERROR</p> <p>+CME ERROR</p>																	
<p>Write Command</p> <p>AT^SCTM=<a href="#">&lt;n&gt;</a>[, <a href="#">&lt;p&gt;</a>]</p> <p>Response(s)</p> <p>OK</p> <p>ERROR</p> <p>+CME ERROR</p>																	
<p>Reference(s)</p> <p>--</p>	<table border="1"> <thead> <tr> <th>PIN</th> <th>ASC0</th> <th>MUX1</th> <th>MUX2</th> <th>MUX3</th> <th>Charge</th> <th></th> <th>Last</th> </tr> </thead> <tbody> <tr> <td><input type="radio"/></td> <td><input checked="" type="radio"/></td> <td><input checked="" type="radio"/></td> <td><input checked="" type="radio"/></td> <td><input checked="" type="radio"/></td> <td><input checked="" type="radio"/></td> <td><input checked="" type="radio"/></td> <td><input type="radio"/></td> </tr> </tbody> </table>	PIN	ASC0	MUX1	MUX2	MUX3	Charge		Last	<input type="radio"/>	<input checked="" type="radio"/>	<input checked="" type="radio"/>	<input checked="" type="radio"/>	<input checked="" type="radio"/>	<input checked="" type="radio"/>	<input checked="" type="radio"/>	<input type="radio"/>
PIN	ASC0	MUX1	MUX2	MUX3	Charge		Last										
<input type="radio"/>	<input checked="" type="radio"/>	<input checked="" type="radio"/>	<input checked="" type="radio"/>	<input checked="" type="radio"/>	<input checked="" type="radio"/>	<input checked="" type="radio"/>	<input type="radio"/>										

### Unsolicited Result Codes

#### URC 1

URCs will be automatically sent to the TA when the temperature reaches or exceeds the critical level, or when it is back to normal.

^SCTM\_A: [<m>](#)

for battery temperature

#### URC 2

^SCTM\_B: [<m>](#)

for module (board) temperature

### Command Description

The read command returns:

- the URC presentation mode
- information about the current temperature range of the module
- The board temperature in Celsius if parameter `<p>=1`.

Please note that the Read command does not indicate the temperature range of the battery. The battery temperature can only be reported by an Unsolicited Result Code.

Select `<n>` to enable or disable the presentation of the URCs. Please note that the setting will not be stored upon Power Down, i.e. after restart or reset, the default `<n>=0` will be restored. To benefit from the URCs `<n>=1` needs to be selected every time you reboot the GSM engine.

### Parameter Description

<code>&lt;n&gt;</code> <sup>(num)</sup>	
0(&F)(P)	Presentation of URCs is disabled (except for <code>&lt;m&gt;</code> equal to -2 or +2).
1	Presentation of URCs is enabled.

<code>&lt;m&gt;</code> <sup>(num)</sup>	
-2	Below lowest temperature limit (causes immediate switch-off)
-1	Below low temperature alert limit
0	Normal operating temperature
1	Above upper temperature alert limit
2	Above uppermost temperature limit (causes immediate switch-off)

<code>&lt;p&gt;</code> <sup>(num)</sup>	
0(&F)(P)	Suppress output of <code>&lt;temp&gt;</code> in test and read command.
1	Output <code>&lt;temp&gt;</code> in test and read command.

`<temp>`<sup>(num)</sup>  
Board temperature in Celsius. Is comprised between the lowest temperature limit and the uppermost temperature limit.

### Notes

- Please refer to the "Hardware Interface Description" for specifications on critical temperature ranges.
- To avoid damage the module will shut down once the critical temperature is exceeded. The procedure is equivalent to the power-down initiated with `AT^SMSO`.
- URCs indicating the alert level "1" or "-1" are intended to enable the user to take appropriate precautions, such as protect the module and the battery from exposure to extreme conditions, or save or back up data etc. The presentation of "1" or "-1" URCs depends on the settings selected with the write command:  
If `<n>=0`: Presentation is enabled for 15 s time after the module was switched on. After 15 s operation, the presentation will be disabled, i.e. no URCs will be generated.  
If `<n>= 1`: Presentation of "1" or "-1" URCs is always enabled.
- Level "2" or "-2" URCs are followed by immediate shutdown. The presentation of these URCs is always enabled, i.e. they will be output even though the factory setting `AT^SCTM=0` was never changed.
- If the temperature limit is exceeded while an emergency call is in progress the engine continues to measure the temperature and to deliver alert messages, but deactivates the shutdown functionality. Once the call is terminated full temperature control will be resumed. If the temperature is still out of range ME switches off immediately.

## Examples

### EXAMPLE 1

URCs issued when the operating temperature is out of range:

^SCTM_A: 1	Caution: Battery close to overtemperature limit.
^SCTM_A: 2	Alert: Battery above overtemperature limit. Engine switches off.
^SCTM_B: 1	Caution: Engine close to overtemperature limit.
^SCTM_B: 2	Alert: Engine is above overtemperature limit and switches off.
^SCTM_A: -1	Caution: Battery close to undertemperature limit.
^SCTM_A: -2	Alert: Battery below undertemperature limit. Engine switches off.
^SCTM_B: -1	Caution: Engine close to undertemperature limit.
^SCTM_B: -2	Alert: Engine is below undertemperature limit and switches off.

### EXAMPLE 2

URCs issued when the temperature is back to normal (URC is output once):

^SCTM_A: 0	Battery temperature back to normal temperature.
^SCTM_B: 0	Engine back to normal temperature.

## 16.6 AT^SSYNC Configure SYNC Pin

The `AT^SSYNC` command serves to configure the SYNC pin of the application interface. The applicability of the different types of `<mode>` is product dependent:

- If you have a TC35i module you may select either mode, depending on whether your application is designed to use the SYNC mode (indicates the current consumption in a transmit burst) or the LED mode (drives a status LED connected to the pin). See [2] for further details on both modes.
- In the case of the TC35i Terminal the `AT^SSYNC` command is intended only to control the status LED placed on the front panel. Therefore, the SYNC mode (`<mode>=0`) is not applicable. Further details on the LED can be found in [3].

### Syntax

<p>Test Command</p> <pre>AT^SSYNC=?</pre> <p>Response(s)</p> <pre>^SSYNC: list of supported &lt;mode&gt;s OK</pre>																	
<p>Read Command</p> <pre>AT^SSYNC?</pre> <p>Response(s)</p> <pre>^SSYNC: &lt;mode&gt; OK</pre>																	
<p>Write Command</p> <pre>AT^SSYNC=&lt;mode&gt;</pre> <p>Response(s)</p> <pre>OK</pre>																	
<p>Reference(s)</p> <pre>--</pre>	<table border="1"> <thead> <tr> <th>PIN</th> <th>ASC0</th> <th>MUX1</th> <th>MUX2</th> <th>MUX3</th> <th>Charge</th> <th>🔔</th> <th>Last</th> </tr> </thead> <tbody> <tr> <td>○</td> <td>●</td> <td>●</td> <td>●</td> <td>●</td> <td>○</td> <td>○</td> <td>○</td> </tr> </tbody> </table>	PIN	ASC0	MUX1	MUX2	MUX3	Charge	🔔	Last	○	●	●	●	●	○	○	○
PIN	ASC0	MUX1	MUX2	MUX3	Charge	🔔	Last										
○	●	●	●	●	○	○	○										

### Parameter Description

<code>&lt;mode&gt;</code> <sup>(num)</sup>	Description
0 <sup>(D)</sup>	<p>SYNC mode: Enables the SYNC pin to indicate growing power consumption during a transmit burst. You can make use of the signal generated by the SYNC pin, if power consumption is your concern. To do so, ensure that your application is capable of processing the signal. Your platform design must be such that the incoming signal causes other components to draw less current. In short, this allows your application to accommodate current drain and thus, supply sufficient current to the GSM engine if required. Note: <code>&lt;mode&gt;=0</code> is the factory default of the TC35i module. In the case of the TC35i Terminal this mode is not applicable and should not be selected.</p>
1	<p>LED mode: <span style="float: right;">m</span> Enables the SYNC pin to drive a status LED installed in your application according to the specifications provided in [2]. The coding of the LED is described in Section 16.6.1, <a href="#">ME status indicated by status LED patterns</a>.</p>



2 LED ode: m  
Like <mode>=1, but, additionally, enables different LED signalization in SLEEP mode depending on the status of PIN authentication and network registration. Please see [AT+CFUN](#) for details on SLEEP mode.  
Note: <mode>=2 is the factory default of the TC35i Terminal.

### 16.6.1 ME status indicated by status LED patterns

The following table lists the possible patterns of status LED behavior, and describes the ME operating status indicated by each pattern if [AT^SSYNC](#) parameter <mode>=1 and <mode>=2.

Please note that during the transition from one LED pattern to another the "on" and/or "off" periods of the LED may vary in length. This is because an event that triggers the change may occur any time and, thus, truncate the current LED pattern at any point.

**Table 16.1:** Modes of the LED and indicated ME functions

LED behavior	ME operating status if <a href="#">AT^SSYNC</a> =1	ME operating status if <a href="#">AT^SSYNC</a> =2
Permanently off	ME is in one of the following modes: POWER DOWN mode, ALARM mode, CHARGE ONLY mode, NON-CYCLIC SLEEP mode, CYCLIC SLEEP mode with no temporary wake-up event in progress.	ME is in one of the following modes: POWER DOWN mode, ALARM mode, CHARGE ONLY mode.
600 ms on / 600ms off	Limited Network Service: No SIM card inserted or no PIN entered, or network search in progress, or ongoing user authentication, or network login in progress.  This applies no matter whether the ME works at full functionality level <a href="#">AT+CFUN</a> =1 or has entered a "temporary wake-up state" during one of the CYCLIC SLEEP modes.	Same as for <a href="#">AT^SSYNC</a> =1
75 ms on / 3 s off	IDLE mode: The mobile is registered to the GSM network (monitoring control channels and user interactions). No call is in progress.  The same LED pattern applies when the ME enters a "temporary wake-up state" during one of the CYCLIC SLEEP modes (e.g. after characters have been received on the serial interface).	Same as for <a href="#">AT^SSYNC</a> =1
Permanently on	Depending on type of call: Voice call: Connected to remote party. Data call: Connected to remote party or exchange of parameters while setting up or disconnecting a call.  This applies no matter whether the ME works at full functionality level <a href="#">AT+CFUN</a> =1 or in one of the CYCLIC SLEEP modes where it wakes up only temporarily to make the call.	Same as for <a href="#">AT^SSYNC</a> =1

LED behavior	ME operating status if AT^SSYNC=1	ME operating status if AT^SSYNC=2
<n> ms on / <n> ms off (See footnote below.)	Not possible: With AT^SSYNC=1, LED signalization is disabled in SLEEP mode.	SLEEP mode is activated (AT+CFUN parameter <fun> ≠ 1), but power saving does not work because the ME is not registered to the GSM network (e.g. SIM not inserted or PIN not entered, and therefore, either no network service or only Limited Network Service is available).
Approx. 15 ms on / <m> ms off (See footnote below.)	Not possible: With AT^SSYNC=1, LED signalization is disabled in SLEEP mode.	SLEEP mode is activated (AT+CFUN parameter <fun> ≠ 1) while the ME is registered to the GSM network. Power saving is properly enabled.

Note: The duration of <n> and <m> depends on the network. In SLEEP mode, the module can only change its LED status during intermittent wake-up periods when listening to paging information from the base station. Therefore the values of <n> and <m> vary as follows:

<n> = value from 1410 ms to 2360 ms  
 <m> = value from 2110 ms to 3770 ms

## 17. Miscellaneous Commands

The AT Commands described in this chapter are related to various areas.

### 17.1 A/ Repeat previous command line

#### Syntax

Exec Command											
A/											
Response(s)											
Reference(s)				PIN	ASC0	MUX1	MUX2	MUX3	Charge		Last
V.250				<input type="radio"/>	<input checked="" type="radio"/>	<input checked="" type="radio"/>	<input checked="" type="radio"/>	<input checked="" type="radio"/>	<input type="radio"/>	<input type="radio"/>	<input type="radio"/>

#### Command Description

Repeat previous command line.

#### Notes

- Line does not need to end with terminating character.
- After beginning with the character "a" or "A" a second character "t", "T" or "/" has to follow. In case of using a wrong second character, it is necessary to start again with character "a" or "A".
- If autobauding is active, the command `A/` cannot be used (see [AT+IPR](#)).

## 17.2 AT3 Set command line termination character

The [AT3](#) command determines the character recognized by the TA to terminate an incoming command line.

### Syntax

Read Command																	
AT3?																	
Response(s)																	
<n>																	
OK																	
Write Command																	
AT3=<n>																	
Response(s)																	
OK																	
ERROR																	
Reference(s)	<table border="1"> <thead> <tr> <th>PIN</th> <th>ASC0</th> <th>MUX1</th> <th>MUX2</th> <th>MUX3</th> <th>Charge</th> <th></th> <th>Last</th> </tr> </thead> <tbody> <tr> <td><input type="radio"/></td> <td><input checked="" type="radio"/></td> <td><input checked="" type="radio"/></td> <td><input checked="" type="radio"/></td> <td><input checked="" type="radio"/></td> <td><input type="radio"/></td> <td><input type="radio"/></td> <td><input type="radio"/></td> </tr> </tbody> </table>	PIN	ASC0	MUX1	MUX2	MUX3	Charge		Last	<input type="radio"/>	<input checked="" type="radio"/>	<input checked="" type="radio"/>	<input checked="" type="radio"/>	<input checked="" type="radio"/>	<input type="radio"/>	<input type="radio"/>	<input type="radio"/>
PIN	ASC0	MUX1	MUX2	MUX3	Charge		Last										
<input type="radio"/>	<input checked="" type="radio"/>	<input checked="" type="radio"/>	<input checked="" type="radio"/>	<input checked="" type="radio"/>	<input type="radio"/>	<input type="radio"/>	<input type="radio"/>										
V.250																	

### Parameter Description

<n> <sup>(num)(&amp;W)(&amp;V)</sup>
command line termination character
000...13 <sup>(&amp;F)</sup> ...127

### Notes

- Using a value other than the default 13 may cause problems when entering commands.
- Whenever you change the setting take into account that the new value has no effect on the URC "[^SHUT-DOWN](#)".

## 17.3 ATS4 Set response formatting character

The [ATS4](#) command determines the character generated by the TA for result code and information text.

### Syntax

Read Command																	
ATS4?																	
Response(s)																	
<n>																	
OK																	
Write Command																	
ATS4=<n>																	
Response(s)																	
OK																	
ERROR																	
Reference(s)	<table border="1"> <thead> <tr> <th>PIN</th> <th>ASC0</th> <th>MUX1</th> <th>MUX2</th> <th>MUX3</th> <th>Charge</th> <th></th> <th>Last</th> </tr> </thead> <tbody> <tr> <td><input type="radio"/></td> <td><input checked="" type="radio"/></td> <td><input checked="" type="radio"/></td> <td><input checked="" type="radio"/></td> <td><input checked="" type="radio"/></td> <td><input type="radio"/></td> <td><input type="radio"/></td> <td><input type="radio"/></td> </tr> </tbody> </table>	PIN	ASC0	MUX1	MUX2	MUX3	Charge		Last	<input type="radio"/>	<input checked="" type="radio"/>	<input checked="" type="radio"/>	<input checked="" type="radio"/>	<input checked="" type="radio"/>	<input type="radio"/>	<input type="radio"/>	<input type="radio"/>
PIN	ASC0	MUX1	MUX2	MUX3	Charge		Last										
<input type="radio"/>	<input checked="" type="radio"/>	<input checked="" type="radio"/>	<input checked="" type="radio"/>	<input checked="" type="radio"/>	<input type="radio"/>	<input type="radio"/>	<input type="radio"/>										
V.250																	

### Parameter Description

<n> <sup>(num)(&amp;W)(&amp;V)</sup>
response formatting character
000...10 <sup>(&amp;F)</sup> ...127

### Note

- Whenever you change the setting take into account that the new value has no effect on the URC "[^SHUT-DOWN](#)".

## 17.4 ATS5 Write command line editing character

### Syntax

Read Command							
ATS5?							
Response(s)							
<n>							
OK							
Write Command							
ATS5=<n>							
Response(s)							
OK							
ERROR							
Reference(s)							
V.250							
PIN	ASC0	MUX1	MUX2	MUX3	Charge		Last
<input type="radio"/>	<input checked="" type="radio"/>	<input checked="" type="radio"/>	<input checked="" type="radio"/>	<input checked="" type="radio"/>	<input type="radio"/>	<input type="radio"/>	<input type="radio"/>

### Command Description

This parameter setting determines the character recognized by TA as a request to delete the immediately preceding character from the command line.

### Parameter Description

<n> <sup>(num)(&amp;W)(&amp;V)</sup>
command line editing character
000...8 <sup>(&amp;F)</sup> ...127

## 18. Appendix

### 18.1 Restricted access to SIM data after SIM PIN authentication

The following commands can be used only after data from the SIM have been read successfully for the first time. Reading starts after successful SIM authentication has been performed, and may take upto 30 seconds depending on the SIM used. While the read process is in progress, an attempt to use any of the following commands will result in "+CME Error: 14" (SIM busy).

We recommend to take advantage of the "**^SSIM READY**" URC. If enabled with **AT^SSET**, this URC acknowledges to the user that SIM data is accessible after SIM PIN authentication. It will be delivered once the ME has completed reading data from the SIM card.

∅ ... AT Command not available

○ ... AT command accessible immediately after PIN entry has returned OK

● ... AT command fully accessible after SIM PIN authentication has been completed

AT Command	Exec	Test	Read	Write
AT+CMGL	●	○	∅	●
AT^SMGL	●	○	∅	●
AT^SCML	●	○	∅	●
AT+CMGR	∅	○	∅	●
AT^SMGR	∅	○	∅	●
AT^SCMR	∅	○	∅	●
AT+CSCA	∅	○	●	○
AT^SSTGI	∅	●	●	●
AT^SSTR	∅	●	●	●
AT+CPBR	∅	●	∅	●
AT+CPBW	∅	●	∅	●
AT+CPBS	∅	●	●	●
AT^SDLD	●	●	∅	∅
AT^SPBC	∅	●	∅	●
AT^SPBD	∅	●	∅	●
AT^SPBG	∅	●	∅	●
AT^SPBS	∅	●	∅	●
ATD><mem><n>	●	∅	∅	∅

## 18.2 Star-Hash (\*#) Network Commands

The following command strings can be sent to the network via [ATD](#) and have to be terminated with a semicolon. The command strings are defined with GSM 2.30 [15].

**Table 18.1:** Star-Hash (\*#) Command Overview

Star-Hash Code	Functionality	Response, also refer to Table 18.3
<b>Phone Security</b>		
*#06#	Query IMEI	<IMEI> OK
**04[2]*oldPin[2]*newPin[2]*new-Pin[2]#	Change SIM pwd	+CME ERROR: <err> / OK
**05[2]*unblKey[2]*newPin[2]*new-Pin[2]#	Change/Unblocking SIM pwd	+CME ERROR: <err> / OK
*#0003*MasterPhoneCode#	Unlock "PS" lock with Master Phone Code	+CME ERROR: <err> / OK
*[*]03*[ZZ]*oldPw*newPw*newPw#	Registration of net password	+CME ERROR: <err> / OK
<b>Phone number presentation</b>		
*#30#	Check status of CLIP (Calling Line Identification Presentation)	+CLIP : <n>,<m> OK (see <a href="#">AT+CLIP</a> )
*#31#	Check status of CLIR (Calling Line Identification Restriction)	+CLIR : <n>,<m> OK (see <a href="#">AT+CLIR</a> )
*31#<Phonenumber>[:]	Suppress CLIR	(see <a href="#">AT+CLIR</a> )
#31#<Phonenumber>[:]	Activate CLIR	(see <a href="#">AT+CLIR</a> )
*#76#	Check status of COLP (Connected Line Identification Presentation)	+COLP : 0,<m> OK (where <m> = active or not active)
*#77#	Check status of COLR (Connected Line Identification Restriction)	+COLR : 0,<m> OK (where <m> = active or not active)
<b>Call forwarding</b>		
(choice of *,#,*,**,##)21*DN*BS#	Act/deact/int/reg/eras CFU	^SCCFC : <reason>, <status>, <class> [...], like +CCFC *) (see: <a href="#">AT+CCFC</a> )
(choice of *,#,*,**,##)67*DN*BS#	Act/deact/int/reg/eras CF busy	see above
(choice of *,#,*,**,##)61*DN*BS*T#	Act/deact/int/reg/eras CF no reply	see above
(choice of *,#,*,**,##)62*DN*BS#	Act/deact/int/reg/eras CF no reach	see above
(choice of *,#,*,**,##)002*DN*BS*T#	Act/deact/int/reg/eras CF all	see above
(choice of *,#,*,**,##)004*DN*BS*T#	Act/deact/int/reg/eras CF all cond.	see above
<b>Call waiting</b>		
(choice of *,#,*,**)43*BS#	Activation/deactivation/int WAIT	+CCWA : <status>, <class> [...], like +CCWA *) (see: <a href="#">AT+CCWA</a> )



Star-Hash Code	Functionality	Response, also refer to Table 18.3
Call barring		
(choice of *,#,*)33*Pw*BS#	Act/deact/int BAOC	^SCLCK : <fac>, <status>, <class> [ , ... ] like +CLCK *) (Refer to AT+CLCK)
(choice of *,#,*)331*Pw*BS#	Act/deact/int BAOIC	see above
(choice of *,#,*)332*Pw*BS#	Act/deact/int BAOIC exc.home	see above
(choice of *,#,*)35*Pw*BS#	Act/deact/int. BAIC	see above
(choice of *,#,*)351*Pw*BS#	Act/deact/int BAIC roaming	see above
#330*Pw*BS#	Deact. All Barring Services	see above
#333*Pw*BS#	Deact. All Outg.Barring Services	see above
#353*Pw*BS#	Deact. All Inc.Barring Services	see above

Call Hold / Multiparty		
C[C] in call	Call hold and multiparty	+CME ERROR: <err> / OK

USSD messages		
[C]...[C]#	Send USSD message	+CME ERROR: <err> / OK
C[C] (excluded 1[C])	Send USSD message	+CME ERROR: <err> / OK

\*) Notes on ^SCCFC, +CCWA, ^SCLCK: The output depends on the affected basic service of the Star-Hash code. One line will be output for every tele- or bearer service coded in basic service code BS.  
 ^SCCFC and ^SCLCK are modified by giving an additional <reason> or <fac> in front of the regular output string generated by the standard commands +CCFC and +CLCK.

**Table 18.2:** Abbreviations of Codes and Parameters used in Table 18.1

Abbreviation	Meaning	Value
ZZ	Type of supplementary services: Barring services All services	330 Not specified
DN	Dialing number	String of digits 0-9
BS	Basic service equivalent to parameter class: Voice FAX SMS SMS+FAX Data circuit asynchron Data circuit synchron dedicated PAD access dedicated Packet access Data circuit asynchron+PAD Data circuit synchron+Packet Data circuit asynchron+synchron+Packet+PAD All Services	11 13 16 12 25 24 27 26 21 22 20 --
T	Time in seconds	In contrast to AT+CCFC, parameter T has no default value. If T is not specified, an operator defined default or the last known value may be used, depending on the network operator.

Abbreviation	Meaning	Value
PW	Password	--
C	Character of TE character set (e.g. asterics, hash or digit in case of USSD, or digits in case of held calls or multiparty calls)	--

**Table 18.3:** Star-Hash Command Response Parameters

Parameter	Meaning
<m>	Mode: 0 = not active, 1 = active
<n>	Unsolicited result code: 0 = presentation disabled, 1 = presentation enabled
<status>	Status: 0 = not active, 1 = active
<class>	Represents BS = basic service, refer to <a href="#">AT+CCFC</a> , <a href="#">AT+CLCK</a>
<fac>	Facility lock, refer to <a href="#">AT+CLCK</a>
<reason>	Call forwarding reason

For exact specification of format and parameters for Star-Hash commands refer to GSM 02.04, Table 3.2 [14] and GSM 02.30, Annex C [15].

**Table 18.4:** Star-Hash Commands for Supplementary Services

Star-Hash Code	Abbreviations in Table 18.1	Functionality
*	act	Activate (except for CLIR, see list above)
**	reg	Register and activate
*#	int	Check status (interrogate)
#	deact	Deactivate (except for CLIR, see list above)
##	eras	Unregister and deactivate

## 18.3 Available AT Commands and Dependency on SIM PIN

- ∅ ... Command not available
- ... Command does not require PIN1
- ... Command requires PIN1
- ⦿ ... Command sometimes requires PIN1

**Table 18.5:** Available AT Commands and Dependency on SIM PIN

AT Command	Exec	Test	Read	Write
Configuration Commands				
AT&F	○	∅	∅	∅
AT&V	○	∅	∅	∅
AT&W	○	∅	∅	∅
ATQ	○	∅	∅	∅
ATV	○	∅	∅	∅
ATX	○	∅	∅	∅
AT\V	○	∅	∅	∅
ATZ	○	∅	∅	∅
AT+CFUN	∅	○	○	○
AT^SMSO	○	○	∅	∅
AT+GCAP	○	○	∅	∅
AT+CMEE	∅	○	○	○
AT+CSCS	∅	○	○	○
AT^SCFG	∅	○	○	○
AT^SM20	∅	○	○	○
Status Control Commands				
AT+CMER	∅	●	●	●
AT+CIND	∅	○	○	○
AT^SIND	∅	○	○	○
AT+CEER	●	●	∅	∅
ATS18	∅	∅	○	○
AT+CPAS	○	○	∅	∅
AT+WS46	∅	○	○	○
Serial Interface Control Commands				
AT\Q	○	∅	∅	∅
AT&C	○	∅	∅	∅
AT&D	○	∅	∅	∅
AT%D	●	●	●	∅
AT&S	○	∅	∅	∅
ATE	○	∅	∅	∅
AT+ICF	∅	○	○	○

AT Command	Exec	Test	Read	Write
AT+IFC	∅	○	○	○
AT+ILRR	∅	●	●	●
AT+IPR	∅	○	○	○
AT+CMUX	∅	○	○	○
AT^STPB	∅	○	○	○
Security Commands				
AT+CPIN	∅	○	○	○
AT+CPIN2	∅	●	●	●
AT^SPIC	○	○	∅	∅
AT+CLCK	∅	●	∅	●
AT^SLCK	∅	●	∅	●
AT+CPWD	∅	●	∅	●
AT^SPWD	∅	●	∅	●
Identification Commands				
ATI	○	∅	∅	∅
AT+CGMI	○	○	∅	∅
AT+GMI	○	○	∅	∅
AT+CGMM	○	○	∅	∅
AT+GMM	○	○	∅	∅
AT+CGMR	○	○	∅	∅
AT+GMR	○	○	∅	∅
AT+CGSN	○	○	∅	∅
AT+GSN	○	○	∅	∅
AT+CIMI	●	●	∅	∅
Call related Commands				
ATA	●	∅	∅	∅
ATD	●	∅	∅	∅
ATD><mem><n>	●	∅	∅	∅
ATD><n>	●	∅	∅	∅
ATD><str>	●	∅	∅	∅
ATDI	●	∅	∅	∅
ATDL	●	∅	∅	∅
ATH	○	∅	∅	∅
AT+CHUP	●	●	∅	∅
AT^SHUP	∅	●	∅	●
ATS0	∅	∅	○	○
ATS6	∅	∅	○	○
ATS7	∅	∅	○	○
ATS8	∅	∅	○	○
ATS10	∅	∅	○	○

AT Command	Exec	Test	Read	Write
ATO	○	∅	∅	∅
+++	○	∅	∅	∅
AT+CBST	∅	○	○	○
AT+CRLP	∅	○	○	○
AT+CLCC	●	●	∅	∅
AT+CR	∅	◐	◐	◐
AT+CRC	∅	○	○	○
AT+CSNS	∅	○	○	○
AT^SCNI	●	●	∅	∅
AT^SLCD	●	●	∅	∅
AT^STCD	●	●	∅	∅
ATP	○	∅	∅	∅
ATT	○	∅	∅	∅
Network Service Commands				
AT+COPN	●	●	∅	∅
AT+COPS	∅	○	◐	◐
AT+CREG	∅	○	○	○
AT+CSQ	○	○	∅	∅
AT^SMONC	●	●	∅	∅
AT^SMOND	●	●	∅	●
AT^MONI	○	○	∅	○
AT^MONP	○	○	∅	○
AT^SALS	∅	●	●	●
AT^SHOM	○	○	∅	∅
AT^SPLM	●	●	∅	∅
AT^SPLR	∅	●	∅	●
AT^SPLW	∅	●	∅	●
Supplementary Service Commands				
AT+CACM	∅	●	●	●
AT^SACM	●	●	∅	●
AT+CAMM	∅	●	●	●
AT+CAOC	●	●	●	●
AT+CCUG	∅	●	●	●
AT+CCFC	∅	●	∅	●
AT+CCWA	∅	●	●	●
AT+CHLD	∅	●	∅	●
AT+CLIP	∅	○	●	○
AT+CLIR	∅	●	●	●
AT+CPUC	∅	●	●	●
AT+CSSN	∅	○	○	○

AT Command	Exec	Test	Read	Write
AT+CUUSD	∅	●	●	●
FAX Commands				
AT+FBADLIN	∅	∅	○	○
AT+FBADMUL	∅	∅	○	○
AT+FBOR	∅	○	○	○
AT+FCIG	∅	○	○	○
AT+FCLASS	∅	○	○	○
AT+FCQ	∅	○	○	○
AT+FCR	∅	∅	∅	○
AT+FDCC	∅	○	○	○
AT+FDFFC	∅	○	○	○
AT+FDIS	∅	○	○	○
AT+FDR	○	∅	∅	∅
AT+FDT	○	∅	∅	○
AT+FET	∅	∅	∅	○
AT+FK	○	∅	∅	∅
AT+FLID	∅	○	○	○
AT+FMDL	∅	∅	○	∅
AT+FMFR	∅	∅	○	∅
AT+FOPT	∅	∅	∅	○
AT+FPHCTO	∅	∅	○	○
AT+FREV	∅	∅	○	∅
AT+FRH	∅	○	∅	○
AT+FRM	∅	○	∅	○
AT+FRS	∅	∅	∅	○
AT+FTH	∅	○	∅	○
AT+FTM	∅	○	∅	○
AT+FTS	∅	∅	∅	○
AT+FVRFC	∅	○	○	○
Short Message Service (SMS) Commands				
AT+CMGC	∅	●	∅	●
AT+CMGD	∅	●	∅	●
AT+CMGF	∅	○	○	○
AT+CMGL	●	●	∅	●
AT+CMGR	∅	●	∅	●
AT+CMGS	∅	●	∅	●
AT+CMGW	●	●	∅	●
AT+CMSS	∅	●	∅	●
AT+CNMA	●	●	∅	●
AT+CNMI	∅	●	●	●

AT Command	Exec	Test	Read	Write
AT+CPMS	∅	●	●	●
AT+CSCA	∅	●	●	●
AT+CSCB	∅	●	●	●
AT+CSDH	∅	●	●	●
AT+CSMP	∅	●	●	●
AT+CSMS	∅	●	●	●
AT^SCML	●	●	∅	●
AT^SCMR	∅	●	∅	●
AT^SCMS	∅	●	∅	●
AT^SCMW	∅	●	∅	●
AT^SLMS	●	●	∅	∅
AT^SMGL	●	●	∅	●
AT^SMGO	∅	●	●	●
AT^SMGR	∅	●	∅	●
AT^SSCONF	∅	○	○	○
AT^SSDA	∅	○	○	○
AT^SSMSS	∅	○	○	○
SIM related Commands				
AT+CRSM	∅	◐	∅	◐
AT^SCKS	∅	○	○	○
AT^SSET	∅	○	○	○
AT^SCID	○	○	∅	∅
AT+CXXCID	○	○	∅	∅
SIM Application Toolkit (SAT) Commands				
AT^SSTA	∅	○	○	○
^SSTN	∅	∅	∅	∅
AT^SSTGI	∅	○	○	○
AT^SSTR	∅	○	○	○
Phonebook Commands				
AT+CPBR	∅	●	∅	●
AT+CPBS	∅	●	●	●
AT+CPBW	∅	●	∅	●
AT^SPBC	∅	●	∅	●
AT^SPBD	∅	●	∅	●
AT^SPBG	∅	●	∅	●
AT^SPBS	∅	●	∅	●
AT^SDLD	●	●	∅	∅
Audio Commands				
ATL	○	∅	∅	∅

AT Command	Exec	Test	Read	Write
ATM	○	∅	∅	∅
AT+CLVL	∅	○	○	○
AT+CMUT	∅	○	○	○
AT+VTD	∅	○	○	○
AT+VTS	∅	○	∅	○
AT^SAIC	∅	○	○	○
AT^SNFA	∅	○	○	○
AT^SNFD	○	○	∅	∅
AT^SNFG	∅	○	∅	○
AT^SNFI	∅	○	○	○
AT^SNFM	∅	○	○	○
AT^SNFO	∅	○	○	○
AT^SNFPT	∅	○	○	○
AT^SNFS	∅	○	○	○
AT^SNFV	∅	○	○	○
AT^SNFW	○	○	∅	∅
AT^SRTC	○	○	○	○
Hardware related Commands				
AT+CALA	∅	○	○	○
AT+CCLK	∅	○	○	○
AT^SBC	∅	○	○	○
AT^SBV	○	○	∅	∅
AT^SCTM	∅	○	○	○
AT^SSYNC	∅	○	○	○
Miscellaneous Commands				
A/	○	∅	∅	∅
ATS3	∅	∅	○	○
ATS4	∅	∅	○	○
ATS5	∅	∅	○	○



## 18.4 Availability of AT Commands Depending on Operating Mode of ME

- ... Command not supported
- ... Command supported

**Table 18.6:** Availability of AT Commands Depending on Operating Mode of ME

AT Command	Normal Mode		Charge
Configuration Commands			
AT&F	●	○	○
AT&V	●	○	○
AT&W	●	○	○
ATQ	●	○	○
ATV	●	○	○
ATX	●	○	○
AT\V	●	○	○
ATZ	●	○	○
AT+CFUN	●	○	○
AT^SMSO	●	●	●
AT+GCAP	●	○	○
AT+CMEE	●	○	○
AT+CSCS	●	○	○
AT^SCFG	●	○	○
AT^SM20	●	○	○
Status Control Commands			
AT+CMER	●	○	○
AT+CIND	●	○	○
AT^SIND	●	○	○
AT+CEER	●	○	○
ATS18	●	○	○
AT+CPAS	●	○	○
AT+WS46	●	○	○
Serial Interface Control Commands			
AT\Q	●	○	○
AT&C	●	○	○
AT&D	●	○	○
AT%D	●	○	○
AT&S	●	○	○
ATE	●	○	○
AT+ICF	●	○	○
AT+IFC	●	○	○
AT+ILRR	●	○	○
AT+IPR	●	○	○

AT Command	Normal Mode		Charge
AT+CMUX	●	○	○
AT^STPB	●	○	○
Security Commands			
AT+CPIN	●	○	○
AT+CPIN2	●	○	○
AT^SPIC	●	○	○
AT+CLCK	●	○	○
AT^SLCK	●	○	○
AT+CPWD	●	○	○
AT^SPWD	●	○	○
Identification Commands			
ATI	●	○	○
AT+CGMI	●	○	○
AT+GMI	●	○	○
AT+CGMM	●	○	○
AT+GMM	●	○	○
AT+CGMR	●	○	○
AT+GMR	●	○	○
AT+CGSN	●	○	○
AT+GSN	●	○	○
AT+CIMI	●	○	○
Call related Commands			
ATA	●	○	○
ATD	●	○	○
ATD><mem><n>	●	○	○
ATD><n>	●	○	○
ATD><str>	●	○	○
ATDI	●	○	○
ATDL	●	○	○
ATH	●	○	○
AT+CHUP	●	○	○
AT^SHUP	●	○	○
ATS0	●	○	○
ATS6	●	○	○
ATS7	●	○	○
ATS8	●	○	○
ATS10	●	○	○
ATO	●	○	○
+++	●	○	○
AT+CBST	●	○	○

AT Command	Normal Mode		Charge
AT+CRLP	●	○	○
AT+CLCC	●	○	○
AT+CR	●	○	○
AT+CRC	●	○	○
AT+CSNS	●	○	○
AT^SCNI	●	○	○
AT^SLCD	●	○	○
AT^STCD	●	○	○
ATP	●	○	○
ATT	●	○	○
Network Service Commands			
AT+COPN	●	○	○
AT+COPS	●	○	○
AT+CREG	●	○	○
AT+CSQ	●	○	○
AT^SMONC	●	○	○
AT^SMOND	●	○	○
AT^MONI	●	○	○
AT^MONP	●	○	○
AT^SALS	●	○	○
AT^SHOM	●	○	○
AT^SPLM	●	○	○
AT^SPLR	●	○	○
AT^SPLW	●	○	○
Supplementary Service Commands			
AT+CACM	●	○	○
AT^SACM	●	○	○
AT+CAMM	●	○	○
AT+CAOC	●	○	○
AT+CCUG	●	○	○
AT+CCFC	●	○	○
AT+CCWA	●	○	○
AT+CHLD	●	○	○
AT+CLIP	●	○	○
AT+CLIR	●	○	○
AT+CPUC	●	○	○
AT+CSSN	●	○	○
AT+CUSD	●	○	○
FAX Commands			
AT+FBADLIN	●	○	○

AT Command	Normal Mode		Charge
AT+FBADMUL	●	○	○
AT+FBOR	●	○	○
AT+FCIG	●	○	○
AT+FCLASS	●	○	○
AT+FCQ	●	○	○
AT+FCR	●	○	○
AT+FDCC	●	○	○
AT+FDFFC	●	○	○
AT+FDIS	●	○	○
AT+FDR	●	○	○
AT+FDT	●	○	○
AT+FET	●	○	○
AT+FK	●	○	○
AT+FLID	●	○	○
AT+FMDL	●	○	○
AT+FMFR	●	○	○
AT+FOPT	●	○	○
AT+FPHCTO	●	○	○
AT+FREV	●	○	○
AT+FRH	●	○	○
AT+FRM	●	○	○
AT+FRS	●	○	○
AT+FTH	●	○	○
AT+FTM	●	○	○
AT+FTS	●	○	○
AT+FVRFC	●	○	○
Short Message Service (SMS) Commands			
AT+CMGC	●	○	○
AT+CMGD	●	○	○
AT+CMGF	●	○	○
AT+CMGL	●	○	○
AT+CMGR	●	○	○
AT+CMGS	●	○	○
AT+CMGW	●	○	○
AT+CMSS	●	○	○
AT+CNMA	●	○	○
AT+CNMI	●	○	○
AT+CPMS	●	○	○
AT+CSCA	●	○	○
AT+CSCB	●	○	○
AT+CSDH	●	○	○

AT Command	Normal Mode		Charge
AT+CSMP	●	○	○
AT+CSMS	●	○	○
AT^SCML	●	○	○
AT^SCMR	●	○	○
AT^SCMS	●	○	○
AT^SCMW	●	○	○
AT^SLMS	●	○	○
AT^SMGL	●	○	○
AT^SMGO	●	○	○
AT^SMGR	●	○	○
AT^SSCONF	●	○	○
AT^SSDA	●	○	○
AT^SSMSS	●	○	○
SIM related Commands			
AT+CRSM	●	○	○
AT^SCKS	●	○	○
AT^SSET	●	○	○
AT^SCID	●	○	○
AT+CXXCID	●	○	○
SIM Application Toolkit (SAT) Commands			
AT^SSTA	●	○	○
^SSTN	●	○	○
AT^SSTGI	●	○	○
AT^SSTR	●	○	○
Phonebook Commands			
AT+CPBR	●	○	○
AT+CPBS	●	○	○
AT+CPBW	●	○	○
AT^SPBC	●	○	○
AT^SPBD	●	○	○
AT^SPBG	●	○	○
AT^SPBS	●	○	○
AT^SDLD	●	○	○
Audio Commands			
ATL	●	○	○
ATM	●	○	○
AT+CLVL	●	○	○
AT+CMUT	●	○	○
AT+VTD	●	○	○

AT Command	Normal Mode		Charge
AT+VTS	●	○	○
AT^SAIC	●	○	○
AT^SNFA	●	○	○
AT^SNFD	●	○	○
AT^SNFG	●	○	○
AT^SNFI	●	○	○
AT^SNFM	●	○	○
AT^SNFO	●	○	○
AT^SNFPT	●	○	○
AT^SNFS	●	○	○
AT^SNFV	●	○	○
AT^SNFW	●	○	○
AT^SRTC	●	○	○
Hardware related Commands			
AT+CALA	●	●	●
AT+CCLK	●	●	●
AT^SBC	●	●	●
AT^SBV	●	●	●
AT^SCTM	●	●	●
AT^SSYNC	●	○	○
Miscellaneous Commands			
A/	●	○	○
ATS3	●	○	○
ATS4	●	○	○
ATS5	●	○	○

## 18.5 AT Command Settings storable with AT&W

**Table 18.7:** Settings Stored to User Profile on ASC0 / MUX Channel 1

AT Command	Stored Parameters
Configuration Commands	
ATQ	<n>
ATV	<value>
ATX	<value>
AT\V	<value>
AT+CMEE	<errMode>
Status Control Commands	
AT+CMER	<mode>, <ind>
ATS18	<n>
Serial Interface Control Commands	
AT\Q	<n>
AT&C	<value>
AT&D	<value>
AT%D	<mode>, <dialType>
AT&S	<value>
ATE	<value>
AT+ICF	<format>, <parity>
AT+IFC	<TEflowcontrol>, <TAflowcontrol>
AT+ILRR	<value>
AT^STPB	<n>
Call related Commands	
ATS0	<n>
ATS6	<n>
ATS7	<n>
ATS8	<n>
ATS10	<n>
AT+CBST	<speed>, <name>, <ce>
AT+CRLP	<iws>, <mws>, <T1>, <N2>
AT+CR	<mode>
AT+CRC	<mode>
Network Service Commands	
AT+COPS	<format>
AT+CREG	<n>

AT Command	Stored Parameters
Supplementary Service Commands	
AT^SACM	<n>
AT+CLIP	<n>
FAX Commands	
AT+FCLASS	<n>
Short Message Service (SMS) Commands	
AT+CMGF	<mode>
AT+CNMI	<mode>, <mt>, <bm>, <ds>, <bfr>
AT+CSCB	<mode>
AT+CSDH	<show>
AT+CSMS	<service>
AT^SMGO	<n>
SIM related Commands	
AT^SCKS	<mode>
AT^SSET	<n>
Miscellaneous Commands	
ATS3	<n>
ATS4	<n>
ATS5	<n>

**Table 18.8:** Settings Stored to User Profile on MUX Channels 2 and 3

AT Command	Stored Parameters
Configuration Commands	
ATQ	<n>
ATV	<value>
ATX	<value>
AT+CMEE	<errMode>
Status Control Commands	
AT+CMER	<mode>, <ind>
Serial Interface Control Commands	
AT\Q	<n>
AT&C	<value>
AT&D	<value>
AT%D	<mode>, <dialType>
AT&S	<value>



AT Command	Stored Parameters
ATE	<value>
AT+ICF	<format>, <parity>
AT+IFC	<TEflowcontrol>, <TAflowcontrol>
AT^STPB	<n>
Call related Commands	
ATS0	<n>
AT+CRC	<mode>
Network Service Commands	
AT+COPS	<format>
AT+CREG	<n>
Supplementary Service Commands	
AT^SACM	<n>
AT+CLIP	<n>
Short Message Service (SMS) Commands	
AT+CMGF	<mode>
AT+CNMI	<mode>, <mt>, <bm>, <ds>, <bfr>
AT+CSCB	<mode>
AT+CSDH	<show>
AT+CSMS	<service>
AT^SMGO	<n>
SIM related Commands	
AT^SCKS	<mode>
AT^SSET	<n>
Miscellaneous Commands	
ATS3	<n>
ATS4	<n>
ATS5	<n>

## 18.6 Factory Default Settings Restorable with AT&F

**Table 18.9:** Factory Default Settings Restorable with AT&F

AT Command	Factory Defaults
Configuration Commands	
ATQ	<n>=0
ATV	<value>=1
ATX	<value>=4
AT\V	<value>=1
AT+CFUN	<fun>=1
AT+CMEE	<errMode>=0
AT+CSGS	<chset>="GSM"
AT^SM20	<CallMode>=1, <CmgwMode>=1
Status Control Commands	
AT+CMER	<mode>=0, <keyp>=0, <disp>=0, <ind>=0, <bfr>=0
AT+CIND	<mode>=1
ATS18	<n>=0
Serial Interface Control Commands	
AT\Q	<n>=0
AT&C	<value>=1
AT&D	<value>=2
AT%D	<mode>=0, <dialType>=" "
AT&S	<value>=0
ATE	<value>=1
AT+ILRR	<value>=0
AT^STPB	<n>=0
Call related Commands	
ATS0	<n>=000
ATS6	<n>=000
ATS7	<n>=060
ATS8	<n>=0
ATS10	<n>=002
AT+CBST	<speed>=7, <name>=0, <ce>=1
AT+CRLP	<iws>=61, <mws>=61, <T1>=78, <N2>=6
AT+CR	<mode>=0
AT+CRC	<mode>=0
Network Service Commands	
AT+COPS	<format>=0
AT+CREG	<n>=0

AT Command	Factory Defaults
AT^SALS	<view>=0, <line>=1
Supplementary Service Commands	
AT^SACM	<n>=0
AT+CLIP	<n>=0
AT+CSSN	<n>=0, <m>=0
AT+CUUSD	<n>=0
FAX Commands	
AT+FCLASS	<n>=0
Short Message Service (SMS) Commands	
AT+CMGF	<mode>=0
AT+CNMI	<mode>=0, <mt>=0, <bm>=0, <ds>=0, <bfr>=1
AT+CSDH	<show>=0
AT+CSMP	<fo>=17, <vp>=167, <dc>=0, <pid>=0
AT+CSMS	<service>=0
AT^SMGO	<n>=0
AT^SSCONF	<ra>=0, <ff>=0
AT^SSDA	<da>=0
AT^SSMSS	<seq>=0
SIM related Commands	
AT^SCKS	<mode>=0
AT^SSET	<n>=0
Phonebook Commands	
AT+CPBS	<storage>="SM"
AT^SPBD	<storage>="SM"
AT^SPBS	<internal-counter>=0
Audio Commands	
AT+VTD	<duration>=1
Hardware related Commands	
AT^SCTM	<n>=0, <p>=0
Miscellaneous Commands	
ATS3	<n>=013
ATS4	<n>=010
ATS5	<n>=008

## 18.7 Summary of Unsolicited Result Codes (URC)

**Table 18.10:** Summary of Unsolicited Result Codes (URC)

AT Command	URC
Configuration Commands	
AT+CFUN	^SYSSTART
AT+CFUN	^SYSSTART CHARGE ONLY MODE
AT^SMSO	^SHUTDOWN
AT^SCFG	^SCFG: "AutoExec", <AutoExecState>, <AutoExecType>, <AutoExecIndex>, <AutoExecMode>, <AutoExecATC>
Status Control Commands	
AT+CMER	+CIEV: <indDescr>, <indValue>
AT^SIND	+CIEV: <indDescr>, <indValue>
AT+CRC	RING
AT+CRC	+CRING: <type>
Network Service Commands	
AT+CREG	+CREG: <stat>
AT+CREG	+CREG: <stat>[, <lac>, <ci>]
AT^SALS	^SALS: <line>
Supplementary Service Commands	
AT^SACM	+CCCM: <ccm>
AT+CCWA	+CCWA: <calling number>, <type of number>, <class>, , <CLI validity>
AT+CCWA	^SCWA
AT+CLIP	+CLIP: <number>, <type>, , [, <alpha>][, <CLI validity>]
AT+CLIP	+CLIP: <number>, <type>
AT+CSSN	+CSSI: <code 1>
AT+CSSN	+CSSU: <code 2>
AT+CUSD	+CUSD: <m>[<str_urc>[<dcs>]]
Short Message Service (SMS) Commands	
AT+CNMI	+CMTI: <mem3>, <index>
AT+CNMI	+CMT: <length><CR><LF><pdu>
AT+CNMI	+CMT: <oa>, <scts>[, <tooa>, <fo>, <pid>, <dcs>, <sca>, <tosca>, <length>]<CR><LF><data>
AT+CNMI	+CBM: <length><CR><LF><pdu>
AT+CNMI	+CBM: <sn>, <mid>, <dcs>, <page>, <pages><CR><LF><data>
AT+CNMI	+CDS: <length><CR><LF><pdu>
AT+CNMI	+CDS: <fo>, <mr>[, <ra>][, <tora>], <scts>, <dt>, <st>
AT+CNMI	+CDSI: <mem3>, <index>
AT^SMGO	^SMGO: <mode>

# TC35i AT Command Set

## 18.7 Summary of Unsolicited Result Codes (URC)

AT Command	URC
SIM related Commands	
AT^SCKS	^SCKS: <SimStatus>
AT^SSET	^SSIM READY
SIM Application Toolkit (SAT) Commands	
^SSTN	^SSTN: <cmdType>
^SSTN	^SSTN: <cmdTerminateValue>
^SSTN	^SSTN: 254
^SSTN	^SSTN: 255
Hardware related Commands	
AT+CALA	+CALA: [<text>]
AT+CALA	^SYSSTART ALARM MODE +CALA: <text>
AT^SBC	^SBC: Undervoltage
AT^SBC	^SBC: Overvoltage warning
AT^SBC	^SBC: Overvoltage shutdown
AT^SCTM	^SCTM_A: <m>
AT^SCTM	^SCTM_B: <m>

## 18.8 Alphabetical List of AT Commands

Table 18.11: Alphabetical List of AT Commands

AT Command	Description	Section and Page
+++	Switch from data mode to command mode	Section 7.17, page 142
^SSTN	SAT Notification	Section 13.2, page 288
A/	Repeat previous command line	Section 17.1, page 347
AT%D	Automatic Dial on DTR Line Activation	Section 4.4, page 80
AT&C	Set circuit Data Carrier Detect (DCD) function mode	Section 4.2, page 78
AT&D	Set circuit Data Terminal Ready (DTR) function mode	Section 4.3, page 79
AT&F	Set all current parameters to manufacturer defaults	Section 2.1, page 26
AT&S	Set circuit Data Set Ready (DSR) function mode	Section 4.5, page 82
AT&V	Display current configuration	Section 2.2, page 27
AT&W	Stores current configuration to user defined profile	Section 2.3, page 30
AT+CACM	Accumulated call meter (ACM) reset or query	Section 9.1, page 180
AT+CALA	Set alarm time	Section 16.1, page 333
AT+CAMM	Accumulated call meter maximum (ACMmax) set or query	Section 9.3, page 183
AT+CAOC	Advice of Charge information	Section 9.4, page 184
AT+CBST	Select bearer service type	Section 7.18, page 143
AT+CCFC	Call forwarding number and conditions control	Section 9.6, page 187
AT+CCLK	Real Time Clock	Section 16.2, page 336
AT+CCUG	Closed User Group	Section 9.5, page 185
AT+CCWA	Call Waiting	Section 9.7, page 191
AT+CEER	Extended Error Report	Section 3.4, page 64
AT+CFUN	Set phone functionality	Section 2.9, page 36
AT+CGMI	Request manufacturer identification	Section 6.2, page 118
AT+CGMM	Request model identification	Section 6.4, page 119
AT+CGMR	Request revision identification of software status	Section 6.6, page 120
AT+CGSN	Request International Mobile Equipment Identity (IMEI)	Section 6.8, page 121
AT+CHLD	Call Hold and Multiparty	Section 9.8, page 195
AT+CHUP	Hang up call	Section 7.9, page 133
AT+CIMI	Request International Mobile Subscriber Identity (IMSI)	Section 6.10, page 122
AT+CIND	Indicator control	Section 3.2, page 59
AT+CLCC	List current calls of ME	Section 7.20, page 145
AT+CLCK	Facility lock	Section 5.4, page 106
AT+CLIP	Calling line identification presentation	Section 9.9, page 197
AT+CLIR	Calling line identification restriction	Section 9.10, page 199
AT+CLVL	Loudspeaker volume level	Section 15.4, page 310
AT+CMEE	Mobile Equipment Error Message Format	Section 2.12, page 43
AT+CMER	Mobile Equipment Event Reporting	Section 3.1, page 57
AT+CMGC	Send an SMS command	Section 11.2, page 241
AT+CMGD	Delete short message	Section 11.3, page 242
AT+CMGF	Select SMS message format	Section 11.4, page 243

AT Command	Description	Section and Page
<a href="#">AT+CMGL</a>	List SMS messages from preferred store	Section <a href="#">11.5</a> , page <a href="#">244</a>
<a href="#">AT+CMGR</a>	Read SMS messages	Section <a href="#">11.6</a> , page <a href="#">246</a>
<a href="#">AT+CMGS</a>	Send Short Message	Section <a href="#">11.7</a> , page <a href="#">248</a>
<a href="#">AT+CMGW</a>	Write Short Messages to Memory	Section <a href="#">11.8</a> , page <a href="#">250</a>
<a href="#">AT+CMSS</a>	Send short messages from storage	Section <a href="#">11.9</a> , page <a href="#">252</a>
<a href="#">AT+CMUT</a>	Mute control	Section <a href="#">15.5</a> , page <a href="#">311</a>
<a href="#">AT+CMUX</a>	Enter multiplex mode	Section <a href="#">4.11</a> , page <a href="#">93</a>
<a href="#">AT+CNMA</a>	New Message Acknowledgement to ME/TE, only phase 2+	Section <a href="#">11.10</a> , page <a href="#">253</a>
<a href="#">AT+CNMI</a>	New SMS message indications	Section <a href="#">11.11</a> , page <a href="#">254</a>
<a href="#">AT+COPN</a>	Read operator names	Section <a href="#">8.1</a> , page <a href="#">154</a>
<a href="#">AT+COPS</a>	Operator Selection	Section <a href="#">8.2</a> , page <a href="#">155</a>
<a href="#">AT+CPAS</a>	Mobile equipment activity status	Section <a href="#">3.6</a> , page <a href="#">75</a>
<a href="#">AT+CPBR</a>	Read from Phonebook	Section <a href="#">14.2</a> , page <a href="#">292</a>
<a href="#">AT+CPBS</a>	Select phonebook memory storage	Section <a href="#">14.3</a> , page <a href="#">295</a>
<a href="#">AT+CPBW</a>	Write into Phonebook	Section <a href="#">14.4</a> , page <a href="#">297</a>
<a href="#">AT+CPIN</a>	PIN Authentication	Section <a href="#">5.1</a> , page <a href="#">97</a>
<a href="#">AT+CPIN2</a>	PIN2 Authentication	Section <a href="#">5.2</a> , page <a href="#">101</a>
<a href="#">AT+CPMS</a>	Preferred SMS message storage	Section <a href="#">11.12</a> , page <a href="#">257</a>
<a href="#">AT+CPUC</a>	Price per unit and currency table	Section <a href="#">9.11</a> , page <a href="#">200</a>
<a href="#">AT+CPWD</a>	Change Password	Section <a href="#">5.6</a> , page <a href="#">112</a>
<a href="#">AT+CR</a>	Service reporting control	Section <a href="#">7.21</a> , page <a href="#">147</a>
<a href="#">AT+CRC</a>	Set Cellular Result Codes for incoming call indication	Section <a href="#">7.22</a> , page <a href="#">148</a>
<a href="#">AT+CREG</a>	Network registration	Section <a href="#">8.3</a> , page <a href="#">158</a>
<a href="#">AT+CRLP</a>	Select radio link protocol parameters for originated non-transparent data calls	Section <a href="#">7.19</a> , page <a href="#">144</a>
<a href="#">AT+CRSM</a>	Restricted SIM Access	Section <a href="#">12.1</a> , page <a href="#">278</a>
<a href="#">AT+CSCA</a>	SMS Service Center Address	Section <a href="#">11.13</a> , page <a href="#">259</a>
<a href="#">AT+CSCB</a>	Select Cell Broadcast Message Indication	Section <a href="#">11.14</a> , page <a href="#">260</a>
<a href="#">AT+CSCS</a>	Select TE character set	Section <a href="#">2.13</a> , page <a href="#">48</a>
<a href="#">AT+CSDH</a>	Show SMS text mode parameters	Section <a href="#">11.15</a> , page <a href="#">261</a>
<a href="#">AT+CSMP</a>	Set SMS text Mode Parameters	Section <a href="#">11.16</a> , page <a href="#">262</a>
<a href="#">AT+CSMS</a>	Select Message Service	Section <a href="#">11.17</a> , page <a href="#">264</a>
<a href="#">AT+CSNS</a>	Single Numbering Scheme	Section <a href="#">7.23</a> , page <a href="#">149</a>
<a href="#">AT+CSQ</a>	Signal quality	Section <a href="#">8.4</a> , page <a href="#">161</a>
<a href="#">AT+CSSN</a>	Supplementary service notifications	Section <a href="#">9.12</a> , page <a href="#">202</a>
<a href="#">AT+CUSD</a>	Supplementary service notifications	Section <a href="#">9.13</a> , page <a href="#">204</a>
<a href="#">AT+CXXCID</a>	Display card ID	Section <a href="#">12.5</a> , page <a href="#">285</a>
<a href="#">AT+FBADLIN</a>	Bad Line Threshold	Section <a href="#">10.2</a> , page <a href="#">209</a>
<a href="#">AT+FBADMUL</a>	Error Threshold Multiplier	Section <a href="#">10.3</a> , page <a href="#">210</a>
<a href="#">AT+FBOR</a>	Query data Bit Order	Section <a href="#">10.4</a> , page <a href="#">211</a>
<a href="#">AT+FCIG</a>	Query or set the Local Polling ID	Section <a href="#">10.5</a> , page <a href="#">212</a>

AT Command	Description	Section and Page
<a href="#">AT+FCLASS</a>	Fax: Select, read or test service class	Section <a href="#">10.6</a> , page <a href="#">213</a>
<a href="#">AT+FCQ</a>	Copy Quality Checking	Section <a href="#">10.7</a> , page <a href="#">214</a>
<a href="#">AT+FCR</a>	Capability to Receive	Section <a href="#">10.8</a> , page <a href="#">215</a>
<a href="#">AT+FDCC</a>	Query or set capabilities	Section <a href="#">10.9</a> , page <a href="#">216</a>
<a href="#">AT+FDFFC</a>	Data Compression Format Conversion	Section <a href="#">10.10</a> , page <a href="#">217</a>
<a href="#">AT+FDIS</a>	Query or set session parameters	Section <a href="#">10.11</a> , page <a href="#">218</a>
<a href="#">AT+FRDR</a>	Begin or continue phase C Data Reception	Section <a href="#">10.12</a> , page <a href="#">219</a>
<a href="#">AT+FDT</a>	Data Transmission	Section <a href="#">10.13</a> , page <a href="#">220</a>
<a href="#">AT+FET</a>	End a page or document	Section <a href="#">10.14</a> , page <a href="#">221</a>
<a href="#">AT+FK</a>	Kill operation, orderly FAX abort	Section <a href="#">10.15</a> , page <a href="#">222</a>
<a href="#">AT+FLID</a>	Query or set the Local Id setting capabilities	Section <a href="#">10.16</a> , page <a href="#">223</a>
<a href="#">AT+FMDL</a>	Identify Product Model	Section <a href="#">10.17</a> , page <a href="#">224</a>
<a href="#">AT+FMFR</a>	Request Manufacturer Identification	Section <a href="#">10.18</a> , page <a href="#">225</a>
<a href="#">AT+FOPT</a>	Set bit Order independently	Section <a href="#">10.19</a> , page <a href="#">226</a>
<a href="#">AT+FPHCTO</a>	DTE Phase C Response Timeout	Section <a href="#">10.20</a> , page <a href="#">227</a>
<a href="#">AT+FREVP</a>	Identify Product Revision	Section <a href="#">10.21</a> , page <a href="#">228</a>
<a href="#">AT+FRH</a>	Receive Data Using HDLC Framing	Section <a href="#">10.22</a> , page <a href="#">229</a>
<a href="#">AT+FRM</a>	Receive Data	Section <a href="#">10.23</a> , page <a href="#">230</a>
<a href="#">AT+FRS</a>	Receive Silence	Section <a href="#">10.24</a> , page <a href="#">231</a>
<a href="#">AT+FTH</a>	Transmit Data Using HDLC Framing	Section <a href="#">10.25</a> , page <a href="#">232</a>
<a href="#">AT+FTM</a>	Transmit Data	Section <a href="#">10.26</a> , page <a href="#">233</a>
<a href="#">AT+FTS</a>	Stop Transmission and Wait	Section <a href="#">10.27</a> , page <a href="#">234</a>
<a href="#">AT+FVRFC</a>	Vertical Resolution Format Conversion	Section <a href="#">10.28</a> , page <a href="#">235</a>
<a href="#">AT+GCAP</a>	Request complete TA capabilities list	Section <a href="#">2.11</a> , page <a href="#">42</a>
<a href="#">AT+GMI</a>	Request manufacturer identification	Section <a href="#">6.3</a> , page <a href="#">118</a>
<a href="#">AT+GMM</a>	Request model identification	Section <a href="#">6.5</a> , page <a href="#">119</a>
<a href="#">AT+GMR</a>	Request revision identification of software status	Section <a href="#">6.7</a> , page <a href="#">120</a>
<a href="#">AT+GSN</a>	Request International Mobile Equipment Identity (IMEI)	Section <a href="#">6.9</a> , page <a href="#">121</a>
<a href="#">AT+ICF</a>	Serial Interface Character Framing	Section <a href="#">4.7</a> , page <a href="#">84</a>
<a href="#">AT+IFC</a>	Set Flow Control separately for data directions	Section <a href="#">4.8</a> , page <a href="#">86</a>
<a href="#">AT+ILRR</a>	Set TE-TA local rate reporting	Section <a href="#">4.9</a> , page <a href="#">88</a>
<a href="#">AT+IPR</a>	Set fixed local rate	Section <a href="#">4.10</a> , page <a href="#">90</a>
<a href="#">AT+VTD</a>	Tone duration	Section <a href="#">15.6</a> , page <a href="#">312</a>
<a href="#">AT+VTS</a>	DTMF and tone generation	Section <a href="#">15.7</a> , page <a href="#">313</a>
<a href="#">AT+WS46</a>	Select wireless network	Section <a href="#">3.7</a> , page <a href="#">76</a>
<a href="#">AT\Q</a>	Flowcontrol	Section <a href="#">4.1</a> , page <a href="#">77</a>
<a href="#">AT\V</a>	Set CONNECT result code format	Section <a href="#">2.7</a> , page <a href="#">34</a>
<a href="#">AT^MONI</a>	Monitor idle mode and dedicated mode	Section <a href="#">8.7</a> , page <a href="#">169</a>
<a href="#">AT^MONP</a>	Monitor neighbour cells	Section <a href="#">8.8</a> , page <a href="#">172</a>
<a href="#">AT^SACM</a>	Advice of charge and query of ACM and ACMmax	Section <a href="#">9.2</a> , page <a href="#">181</a>
<a href="#">AT^SAIC</a>	Audio Interface Configuration	Section <a href="#">15.8</a> , page <a href="#">314</a>
<a href="#">AT^SALS</a>	Alternate Line Service	Section <a href="#">8.9</a> , page <a href="#">174</a>



AT Command	Description	Section and Page
<a href="#">AT^SBC</a>	Battery charging / discharging and charge control	Section <a href="#">16.3</a> , page <a href="#">337</a>
<a href="#">AT^SBV</a>	Battery/Supply Voltage	Section <a href="#">16.4</a> , page <a href="#">340</a>
<a href="#">AT^SCFG</a>	Extended Configuration Settings	Section <a href="#">2.14</a> , page <a href="#">49</a>
<a href="#">AT^SCID</a>	Display SIM card identification number	Section <a href="#">12.4</a> , page <a href="#">284</a>
<a href="#">AT^SCKS</a>	Query SIM and Chip Card Holder Status	Section <a href="#">12.2</a> , page <a href="#">281</a>
<a href="#">AT^SCML</a>	List Concatenated Short Messages from preferred store	Section <a href="#">11.18</a> , page <a href="#">266</a>
<a href="#">AT^SCMR</a>	Read Concatenated Short Messages	Section <a href="#">11.19</a> , page <a href="#">267</a>
<a href="#">AT^SCMS</a>	Send Concatenated Short Messages	Section <a href="#">11.20</a> , page <a href="#">268</a>
<a href="#">AT^SCMW</a>	Write Concatenated Short Messages to Memory	Section <a href="#">11.21</a> , page <a href="#">269</a>
<a href="#">AT^SCNI</a>	List Call Number Information	Section <a href="#">7.24</a> , page <a href="#">150</a>
<a href="#">AT^SCTM</a>	Set critical operating temperature presentation mode or query temperature	Section <a href="#">16.5</a> , page <a href="#">341</a>
<a href="#">AT^SDLD</a>	Delete the 'last number redial' memory	Section <a href="#">14.9</a> , page <a href="#">307</a>
<a href="#">AT^SHOM</a>	Display Homezone	Section <a href="#">8.10</a> , page <a href="#">176</a>
<a href="#">AT^SHUP</a>	Hang up call(s) indicating a specific GSM04.08 release cause	Section <a href="#">7.10</a> , page <a href="#">134</a>
<a href="#">AT^SIND</a>	Extended Indicator Control	Section <a href="#">3.3</a> , page <a href="#">62</a>
<a href="#">AT^SLCD</a>	Display Last Call Duration	Section <a href="#">7.25</a> , page <a href="#">151</a>
<a href="#">AT^SLCK</a>	Facility lock	Section <a href="#">5.5</a> , page <a href="#">111</a>
<a href="#">AT^SLMS</a>	List SMS Memory Storage	Section <a href="#">11.22</a> , page <a href="#">270</a>
<a href="#">AT^SM20</a>	Set M20 compatibility mode	Section <a href="#">2.15</a> , page <a href="#">56</a>
<a href="#">AT^SMGL</a>	List Short Messages from preferred store without setting status to REC READ	Section <a href="#">11.23</a> , page <a href="#">271</a>
<a href="#">AT^SMGO</a>	Set or query SMS overflow presentation mode or query SMS overflow	Section <a href="#">11.24</a> , page <a href="#">272</a>
<a href="#">AT^SMGR</a>	Read short message without setting status to REC READ	Section <a href="#">11.25</a> , page <a href="#">274</a>
<a href="#">AT^SMONC</a>	Cell Monitoring	Section <a href="#">8.5</a> , page <a href="#">162</a>
<a href="#">AT^SMOND</a>	Cell Monitoring	Section <a href="#">8.6</a> , page <a href="#">164</a>
<a href="#">AT^SMSO</a>	Switch off mobile station	Section <a href="#">2.10</a> , page <a href="#">41</a>
<a href="#">AT^SNFA</a>	Set or query of microphone attenuation	Section <a href="#">15.9</a> , page <a href="#">316</a>
<a href="#">AT^SNFD</a>	Set audio parameters to manufacturer default values	Section <a href="#">15.10</a> , page <a href="#">318</a>
<a href="#">AT^SNFG</a>	Generate Tone	Section <a href="#">15.11</a> , page <a href="#">319</a>
<a href="#">AT^SNFI</a>	Set microphone path parameters	Section <a href="#">15.12</a> , page <a href="#">321</a>
<a href="#">AT^SNFM</a>	Mute microphone	Section <a href="#">15.13</a> , page <a href="#">322</a>
<a href="#">AT^SNFO</a>	Set audio output (= loudspeaker path) parameter	Section <a href="#">15.14</a> , page <a href="#">323</a>
<a href="#">AT^SNFPT</a>	Set progress tones	Section <a href="#">15.15</a> , page <a href="#">325</a>
<a href="#">AT^SNFS</a>	Select audio hardware set	Section <a href="#">15.16</a> , page <a href="#">326</a>
<a href="#">AT^SNFV</a>	Set loudspeaker volume	Section <a href="#">15.17</a> , page <a href="#">329</a>
<a href="#">AT^SNFW</a>	Write audio setting in non-volatile store	Section <a href="#">15.18</a> , page <a href="#">330</a>
<a href="#">AT^SPBC</a>	Find first matching entry in sorted phonebook	Section <a href="#">14.5</a> , page <a href="#">300</a>
<a href="#">AT^SPBD</a>	Purge phonebook memory storage	Section <a href="#">14.6</a> , page <a href="#">301</a>
<a href="#">AT^SPBG</a>	Display phonebook entries in alphabetical order	Section <a href="#">14.7</a> , page <a href="#">302</a>
<a href="#">AT^SPBS</a>	Step through the selected phonebook alphabetically	Section <a href="#">14.8</a> , page <a href="#">304</a>

AT Command	Description	Section and Page
<a href="#">AT^SPIC</a>	Display PIN counter	Section <a href="#">5.3</a> , page <a href="#">103</a>
<a href="#">AT^SPLM</a>	Read the PLMN list	Section <a href="#">8.11</a> , page <a href="#">177</a>
<a href="#">AT^SPLR</a>	Read entry from the preferred operators list	Section <a href="#">8.12</a> , page <a href="#">178</a>
<a href="#">AT^SPLW</a>	Write an entry to the preferred operators list	Section <a href="#">8.13</a> , page <a href="#">179</a>
<a href="#">AT^SPWD</a>	Change Password	Section <a href="#">5.7</a> , page <a href="#">116</a>
<a href="#">AT^SRTC</a>	Ring tone configuration	Section <a href="#">15.19</a> , page <a href="#">331</a>
<a href="#">AT^SSCONF</a>	SMS Command Configuration	Section <a href="#">11.26</a> , page <a href="#">275</a>
<a href="#">AT^SSDA</a>	Set SMS Display Availability	Section <a href="#">11.27</a> , page <a href="#">276</a>
<a href="#">AT^SSET</a>	Indicate SIM data ready	Section <a href="#">12.3</a> , page <a href="#">283</a>
<a href="#">AT^SSMSS</a>	Set Short Message Storage Sequence	Section <a href="#">11.28</a> , page <a href="#">277</a>
<a href="#">AT^SSTA</a>	SAT Interface Activation	Section <a href="#">13.1</a> , page <a href="#">286</a>
<a href="#">AT^SSTGI</a>	SAT Get Information	Section <a href="#">13.3</a> , page <a href="#">289</a>
<a href="#">AT^SSTR</a>	SAT Response	Section <a href="#">13.4</a> , page <a href="#">290</a>
<a href="#">AT^SSYNC</a>	Configure SYNC Pin	Section <a href="#">16.6</a> , page <a href="#">344</a>
<a href="#">AT^STCD</a>	Display Total Call Duration	Section <a href="#">7.26</a> , page <a href="#">152</a>
<a href="#">AT^STPB</a>	Transmit Parity Bit (for 7E1 and 7O1 only)	Section <a href="#">4.12</a> , page <a href="#">96</a>
<a href="#">ATA</a>	Answer a call	Section <a href="#">7.1</a> , page <a href="#">123</a>
<a href="#">ATD</a>	Mobile originated call to specified number	Section <a href="#">7.2</a> , page <a href="#">124</a>
<a href="#">ATD&gt;&lt;mem&gt;&lt;n&gt;</a>	Mobile originated call using specific memory and index number	Section <a href="#">7.3</a> , page <a href="#">126</a>
<a href="#">ATD&gt;&lt;n&gt;</a>	Mobile originated call from active memory using index number	Section <a href="#">7.4</a> , page <a href="#">128</a>
<a href="#">ATD&gt;&lt;str&gt;</a>	Mobile originated call from active memory using corresponding field	Section <a href="#">7.5</a> , page <a href="#">129</a>
<a href="#">ATDI</a>	Mobile originated call to ISDN number	Section <a href="#">7.6</a> , page <a href="#">130</a>
<a href="#">ATDL</a>	Redial last number used	Section <a href="#">7.7</a> , page <a href="#">131</a>
<a href="#">ATE</a>	Enable command echo	Section <a href="#">4.6</a> , page <a href="#">83</a>
<a href="#">ATH</a>	Disconnect existing connection	Section <a href="#">7.8</a> , page <a href="#">132</a>
<a href="#">ATI</a>	Display product identification information	Section <a href="#">6.1</a> , page <a href="#">117</a>
<a href="#">ATL</a>	Set monitor speaker loudness	Section <a href="#">15.2</a> , page <a href="#">309</a>
<a href="#">ATM</a>	Set monitor speaker mode	Section <a href="#">15.3</a> , page <a href="#">309</a>
<a href="#">ATO</a>	Switch from command mode to data mode	Section <a href="#">7.16</a> , page <a href="#">141</a>
<a href="#">ATP</a>	Select pulse dialing	Section <a href="#">7.27</a> , page <a href="#">153</a>
<a href="#">ATQ</a>	Set result code presentation mode	Section <a href="#">2.4</a> , page <a href="#">31</a>
<a href="#">ATS0</a>	Set number of rings before automatically answering a call	Section <a href="#">7.11</a> , page <a href="#">136</a>
<a href="#">ATS10</a>	Set disconnect delay after indicating the absence of data carrier	Section <a href="#">7.15</a> , page <a href="#">140</a>
<a href="#">ATS18</a>	Extended call release report	Section <a href="#">3.5</a> , page <a href="#">73</a>
<a href="#">ATS3</a>	Set command line termination character	Section <a href="#">17.2</a> , page <a href="#">348</a>
<a href="#">ATS4</a>	Set response formatting character	Section <a href="#">17.3</a> , page <a href="#">349</a>
<a href="#">ATS5</a>	Write command line editing character	Section <a href="#">17.4</a> , page <a href="#">350</a>
<a href="#">ATS6</a>	Set pause before blind dialing	Section <a href="#">7.12</a> , page <a href="#">137</a>
<a href="#">ATS7</a>	Set number of seconds to wait for connection completion	Section <a href="#">7.13</a> , page <a href="#">138</a>

---

AT Command	Description	Section and Page
<a href="#">ATS8</a>	Set number of seconds to wait for comma dialing modifier	Section <a href="#">7.14</a> , page <a href="#">139</a>
<a href="#">ATT</a>	Select tone dialing	Section <a href="#">7.28</a> , page <a href="#">153</a>
<a href="#">ATV</a>	Set result code format mode	Section <a href="#">2.5</a> , page <a href="#">32</a>
<a href="#">ATX</a>	Set CONNECT result code format and call monitoring	Section <a href="#">2.6</a> , page <a href="#">33</a>
<a href="#">ATZ</a>	Set all current parameters to user defined profile	Section <a href="#">2.8</a> , page <a href="#">35</a>